



**DIVISION: 03 00 00—CONCRETE**

Section: 03 16 00—Concrete Anchors

**DIVISION: 05 00 00—METALS**

Section: 05 05 19—Post-installed Concrete Anchors

**REPORT HOLDER:**

HILTI, INC.

**EVALUATION SUBJECT:**

**HILTI HIT-HY 200 V3 ADHESIVE ANCHORS AND POST INSTALLED REINFORCING BAR CONNECTIONS IN CONCRETE**

### 1.0 EVALUATION SCOPE

**Compliance with the following codes:**

- 2021, 2018, 2015, and 2012 *International Building Code*® (IBC)
- 2021, 2018, 2015, and 2012 *International Residential Code*® (IRC)

For evaluation for compliance with codes adopted by the Los Angeles Department of Building and Safety (LADBS), see [ESR-4868 LABC and LARC Supplement](#).

**Property evaluated:**

Structural

### 2.0 USES

Adhesive anchors and reinforcing bars installed using the Hilti HIT-HY 200 V3 Adhesive Anchoring System and Post-Installed Reinforcing Bar System are used to resist static, wind and earthquake (Seismic Design Categories A through F) tension and shear loads in cracked and uncracked normal-weight or lightweight concrete having a specified compressive strength,  $f'_c$ , of 2,500 psi to 8,500 psi (17.2 MPa to 58.6 MPa).

The anchor system complies with anchors as described in Section 1901.3 of the 2021, 2018 and 2015 IBC, and Section 1909 of the 2012 IBC and is an alternative to cast-in-place anchors described in Section 1908 of the 2012 IBC. The anchor systems may also be used where an engineered design is submitted in accordance with Section R301.1.3 of the IRC.

The post-installed reinforcing bar system is an alternative to cast-in-place reinforcing bars governed by ACI 318 and IBC Chapter 19.

### 3.0 DESCRIPTION

#### 3.1 General:

The Hilti HIT-HY 200 V3 Adhesive Anchoring System and Post-Installed Reinforcing Bar System are comprised of the following components:

- Hilti HIT-HY 200 V3 adhesive packaged in foil packs (either Hilti HIT-HY 200-A V3 or Hilti HIT-HY 200-R V3)
- Adhesive mixing and dispensing equipment
- Equipment for hole cleaning and adhesive injection

The Hilti HIT-HY 200 V3 Adhesive Anchoring System may be used with continuously threaded rod, Hilti HIT-Z(-R) anchor rods, Hilti HIS-(R)N internally threaded inserts or deformed steel reinforcing bars as depicted in Figure 1. The Hilti HIT-HY 200 V3 Post-Installed Reinforcing Bar System may only be used with deformed steel reinforcing bars as depicted in Figure 2. The primary components of the Hilti Adhesive Anchoring and Post-Installed Reinforcing Bar Systems, including the Hilti HIT-HY 200 V3 Adhesive, HIT-RE-M static mixing nozzle and steel anchoring elements, are shown in Figure 5 of this report.

The manufacturer's printed Installation instructions (MPII), as included with each adhesive unit package, are replicated as Figure 6.

#### 3.2 Materials:

**3.2.1 Hilti HIT-HY 200 V3 Adhesive:** Hilti HIT-HY 200 V3 Adhesive is an injectable, two-component hybrid adhesive. The two components are separated by means of a dual-cylinder foil pack attached to a manifold. The two components combine and react when dispensed through a static mixing nozzle attached to the manifold. Hilti HIT-HY 200 V3 is available in 11.1-ounce (330 mL) and 16.9-ounce (500 mL) foil packs. The manifold attached to each foil pack is stamped with the adhesive expiration date. The shelf life, as indicated by the expiration date, applies to an unopened foil pack stored in a dry, dark environment and in accordance with Figure 6.

Hilti HIT-HY 200 V3 Adhesive is available in two options, Hilti HIT-HY 200-A V3 and Hilti HIT-HY 200-R V3. Both options are subject to the same technical data as set forth in this report. Hilti HIT-HY 200-A V3 will have shorter working times and curing times than Hilti HIT-HY 200-R V3. The packaging for each option employs a different color, which helps the user distinguish between the two adhesives.

#### 3.2.2 Hole Cleaning Equipment:

**3.2.2.1 Standard Equipment:** Standard hole cleaning equipment, comprised of steel wire brushes and air nozzles, is described in Figure 6 of this report.

**3.2.2.2 Hilti Safe-Set™ System:** The Hilti Safe-Set™ with Hilti HIT-HY 200 V3 consists of one of the following:

- For the Hilti HIT-Z and HIT-Z-R anchor rods, hole cleaning is not required after drilling the hole, except if the hole is drilled with a diamond core drill bit.
- For the elements described in Sections 3.2.4.2 through 3.2.4.4 and Section 3.2.5, the Hilti TE-CD or TE-YD hollow carbide drill bit with a carbide drilling head conforming to ANSI B212.15. Used in conjunction with a Hilti vacuum with a minimum value for the maximum volumetric flow rate of 129 CFM (61 *ℓ*/s), the Hilti TE-CD or TE-YD drill bit will remove the drilling dust, automatically cleaning the hole.

### 3.2.3 Hole Preparation Equipment:

**3.2.3.1 Hilti Safe-Set™ System: TE-YRT Roughening Tool:** For the elements described in Sections 3.2.5.2 through 3.2.5.4 and Tables 12, 13, 15, 18, 19, 21, 24, 25, 28 and 29, the Hilti TE-YRT roughening tool with a carbide roughening head is used for hole preparation in conjunction with holes core drilled with a diamond core bit as illustrated in Section 4.1.4.2 of this report.

**3.2.4 Dispensers:** Hilti HIT-HY 200 V3 must be dispensed with manual or electric dispensers provided by Hilti.

### 3.2.5 Anchor Elements:

**3.2.5.1 Hilti HIT-Z and HIT-Z-R Anchor Rods:** Hilti HIT-Z and HIT-Z-R anchor rods have a conical shape on the embedded section and a threaded section above the concrete surface. Mechanical properties for the Hilti HIT-Z and HIT-Z-R anchor rods are provided in Table 2. The rods are available in diameters as shown in Table 7 and Figure 1. Hilti HIT-Z anchor rods are produced from carbon steel and furnished with a 0.005-millimeter-thick (5  $\mu$ m) zinc electroplated coating. Hilti HIT-Z-R anchor rods are fabricated from grade 316 stainless steel.

**3.2.5.2 Threaded Steel Rods:** Threaded steel rods must be clean, continuously threaded rods (all-thread) in diameters as described in Tables 11 and 17 and Figure 1 of this report. Steel design information for common grades of threaded rods is provided in Table 3. Carbon steel threaded rods may be furnished with a 0.0002-inch-thick (0.005 mm) zinc electroplated coating complying with ASTM B633 SC 1 or must be hot-dipped galvanized complying with ASTM A153, Class C or D. Stainless steel threaded rods must comply with ASTM F593 or ISO 3506 A4. Threaded steel rods must be straight and free of indentations or other defects along their length. The ends may be stamped with identifying marks and the embedded end may be blunt cut or cut on the bias to a chisel point.

**3.2.5.3 Steel Reinforcing Bars for use in Post-Installed Anchor Applications:** Steel reinforcing bars are deformed bars as described in Table 4 of this report. Tables 11A, 17, and 23 and Figure 1 summarize reinforcing bar size ranges. The embedded portions of reinforcing bars must be straight, and free of mill scale, rust, mud, oil and other coatings (other than zinc) that may impair the bond with the adhesive. Reinforcing bars must not be bent after installation except as set forth in ACI 318-19 Section 26.6.3.2(b) ACI 318-14 Section 26.6.3.1(b) or ACI 318-11 Section 7.3.2, as applicable, with the additional condition that the bars must be bent cold, and heating of reinforcing bars to facilitate field bending is not permitted.

**3.2.5.4 Hilti HIS-N and HIS-RN Inserts:** Hilti HIS-N and HIS-RN inserts have a profile on the external surface and are internally threaded. Mechanical properties for Hilti HIS-N and HIS-RN inserts are provided in Table 5. The inserts are available in diameters and lengths as shown in Table 27 and

Figure 1. Hilti HIS-N inserts are produced from carbon steel and furnished with a 0.005-millimeter-thick (5  $\mu$ m) zinc electroplated coating complying with ASTM B633 SC 1. The stainless steel Hilti HIS-RN inserts are fabricated from X5CrNiMo17122 K700 steel conforming to DIN 17440. Specifications for common bolt types that may be used in conjunction with Hilti HIS-N and HIS-RN inserts are provided in Table 6. Bolt grade and material type (carbon, stainless) must be matched to the insert. Strength reduction factors,  $\phi$ , corresponding to brittle steel elements must be used for Hilti HIS-N and HIS-RN inserts.

**3.2.5.5 Ductility:** In accordance with ACI 318-19 and ACI 318-14 2.3 or ACI 318-11 D.1, as applicable, in order for a steel element to be considered ductile, the tested elongation must be at least 14 percent and reduction of area must be at least 30 percent. Steel elements with a tested elongation of less than 14 percent or a reduction of area of less than 30 percent, or both, are considered brittle. Values for various steel materials are provided in Tables 2, 3, and 6 of this report. Where values are nonconforming or unstated, the steel must be considered brittle.

**3.2.6 Steel Reinforcing Bars for Use in Post-Installed Reinforcing Bar Connections:** Steel reinforcing bars used in post-installed reinforcing bar connections are deformed bars (rebar) as depicted in Figures 2 and 3. Tables 30, 31, 32, and Figure 6 summarize reinforcing bar size ranges. The embedded portions of reinforcing bars must be straight, and free of mill scale, rust and other coatings that may impair the bond with the adhesive. Reinforcing bars must not be bent after installation, except as set forth in Section 26.6.3.2(b) of ACI 318-19, Section 26.6.3.1(b) of ACI 318-14 or Section 7.3.2 of ACI 318-11, as applicable, with the additional condition that the bars must be bent cold, and heating of reinforcing bars to facilitate field bending is not permitted.

### 3.3 Concrete:

Normal-weight and lightweight concrete must comply with Sections 1903 and 1905 of the IBC, as applicable. The specified compressive strength of the concrete must be from 2,500 psi to 8,500 psi (17.2 MPa to 58.6 MPa).

## 4.0 DESIGN AND INSTALLATION

### 4.1 Strength Design of Post-Installed Anchors:

Refer to Table 1 for the design parameters for specific installed elements, and refer to Section 4.1.4.2 for a table to determine the applicable design bond strength or pullout strength.

**4.1.1 General:** The design strength of anchors under the 2021 IBC, as well as the 2021 IRC, must be determined in accordance with ACI 318-19 and this report. The design strength of anchors under the 2018 and 2015 IBC and 2018 and 2015 IRC must be determined in accordance with ACI 318-14 and this report. The design strength of anchors under the 2012 IBC, as well as the 2012 IRC must be determined in accordance with ACI 318-11 and this report.

Design parameters are based on ACI 318-19 for use with the 2021 IBC, ACI 318-14 for use with the 2018 and 2015 IBC, and ACI 318-11 for use with the 2012 IBC unless noted otherwise in Sections 4.1.1 through 4.1.11 of this report.

The strength design of anchors must comply with ACI 318-19 17.5.1.2 or ACI 318-14 17.3.1 or ACI 318-11 D.4.1 as applicable, except as required in ACI 318-19 17.10 or ACI 318-14 17.2.3 or ACI 318-11 D.3.3, as applicable.

Design parameters are provided in Table 7 through Table 29. Strength reduction factors,  $\phi$ , as given in ACI 318-19 17.5.3, ACI 318-14 17.3.3 or ACI 318-11 D.4.3, as applicable must be used for load combinations calculated in accordance with Section 1605.1 of the 2021 IBC or Section

1605.2 of the 2018, 2015 and 2012 IBC or ACI 318-19 and ACI 318-14 5.3 or ACI 318-11 9.2, as applicable. Strength reduction factors,  $\phi$ , as given in ACI 318-11 D.4.4 must be used for load combinations calculated in accordance with ACI 318-11 Appendix C.

**4.1.2 Static Steel Strength in Tension: The nominal static steel strength of a single anchor in tension,  $N_{sa}$ , in accordance with ACI 318-19 17.6.1.2, ACI 318-14 17.4.1.2 or ACI 318-11 Section D.5.1.2, as applicable and the associated strength reduction factors,  $\phi$ , in accordance with ACI 318-19 17.5.3, ACI 318-14 17.3.3 or ACI 318-11 Section D.4.3, as applicable, are provided in the tables outlined in Table 1 for the anchor element types included in this report.**

**4.1.3 Static Concrete Breakout Strength in Tension:** The nominal concrete breakout strength of a single anchor or group of anchors in tension,  $N_{cb}$  or  $N_{cbg}$ , must be calculated in accordance with ACI 318-19 17.6.2, ACI 318-14 17.4.2 or ACI 318-11 D.5.2, as applicable, with the following addition:

The basic concrete breakout strength of a single anchor in tension,  $N_b$ , must be calculated in accordance with ACI 318-19 17.6.2.2, ACI 318-14 17.4.2.2 or ACI 318-11 D.5.2.2, as applicable using the values of  $k_{c,cr}$  and  $k_{c,uncr}$  as described in this report. Where analysis indicates no cracking in accordance with ACI 318-19 17.6.2.5, ACI 318-14 17.4.2.6 or ACI 318-11 D.5.2.6, as applicable,  $N_b$  must be calculated using  $k_{c,uncr}$  and  $\Psi_{c,N} = 1.0$ . See Table 1. For anchors in lightweight concrete, see ACI 318-19 17.2.4, ACI 318-14 17.2.6 or ACI 318-11 D.3.6, as applicable. The value of  $f'_c$  used for calculation must be limited to 8,000 psi (55 MPa) in accordance with ACI 318-19 17.3.1, ACI 318-14 17.2.7 or ACI 318-11 D.3.7, as applicable. Additional information for the determination of nominal bond strength in tension is given in Section 4.1.4 of this report.

**4.1.4 Static Bond Strength/Static Pullout Strength in Tension:**

**4.1.4.1 Static Pullout Strength In Tension: Hilti HIT-Z and HIT-Z-R Anchor Rods:** The nominal static pullout strength of a single anchor in accordance with ACI 318-19 17.6.3.1 and 17.6.3.2.1, ACI 318-14 17.4.3.1 and 17.4.3.2 or ACI 318-11 D.5.3.1 and D.5.3.2, as applicable, in cracked and uncracked concrete,  $N_{p,cr}$  and  $N_{p,uncr}$ , respectively, is given in Table 10. For all design cases  $\Psi_{c,P} = 1.0$ .

Pullout strength values are a function of the concrete compressive strength, whether the concrete is cracked or uncracked, the drilling method (hammer drill, including Hilti hollow drill bit, diamond core drill) and installation conditions (dry or water-saturated). The resulting characteristic pullout strength must be multiplied by the associated strength reduction factor  $\phi_{nn}$  as follows:

HILTI HIT-Z AND HIT-Z-R THREADED RODS				
DRILLING METHOD	CONCRETE TYPE	PERMISSIBLE INSTALLATION CONDITIONS	PULLOUT STRENGTH	ASSOCIATED STRENGTH REDUCTION FACTOR
Hammer-drill (or Hilti TE-CD or TE-YD Hollow Drill Bit) or Diamond Core Bit	Uncracked	Dry	$N_{p,uncr}$	$\phi_d$
		Water saturated	$N_{p,uncr}$	$\phi_{ws}$
	Cracked	Dry	$N_{p,cr}$	$\phi_d$
		Water saturated	$N_{p,cr}$	$\phi_{ws}$

Section 4.1.4.2 of this report presents a pullout strength design selection table. Strength reduction factors for determination of the bond strength are given in the tables referenced in Table 1 of this report.

**4.1.4.2 Static Bond Strength in Tension: Threaded Rod, Steel Reinforcing Bars, and Hilti HIS-N and HIS-RN Inserts:** The nominal static bond strength of a single adhesive anchor or group of adhesive anchors in tension,  $N_a$  or  $N_{ag}$ , must be calculated in accordance with ACI 318-19 17.6.5, ACI 318-14 17.4.5 or ACI 318-11 D.5.5, as applicable. Bond strength values are a function of the concrete compressive strength, whether the concrete is cracked or uncracked, the concrete temperature range, and the installation conditions (dry or water-saturated concrete). The resulting characteristic bond strength shall be multiplied by the associated strength reduction factor  $\phi_{nn}$  as follows:

DRILLING METHOD	CONCRETE TYPE	PERMISSIBLE INSTALLATION CONDITIONS	BOND STRENGTH	ASSOCIATED STRENGTH REDUCTION FACTOR
Hammer-drill (or Hilti TE-CD or TE-YD Hollow Drill Bit) or Diamond Core Bit with Hilti TE-YRT roughening tool	Uncracked	Dry	$\tau_{k,uncr}$	$\phi_d$
		Water saturated	$\tau_{k,uncr}$	$\phi_{ws}$
	Cracked	Dry	$\tau_{k,cr}$	$\phi_d$
		Water saturated	$\tau_{k,cr}$	$\phi_{ws}$
Hammer-drill (or Hilti TE-CD or TE-YD Hollow Drill Bit)	Uncracked	Water-filled	$\tau_{k,uncr}$	$\phi_{wf}$
	Cracked		$\tau_{k,cr}$	$\phi_{wf}$

Strength reduction factors for determination of the bond strength are outlined in Table 1 of this report. Adjustments to the bond strength may also be made for increased concrete compressive strength as noted in the footnotes to the bond strength tables. For anchors in lightweight concrete see ACI 318-19 17.2.4, ACI 318-14 17.2.6, or ACI 318-11 D.3.6, as applicable.

**4.1.5 Static Steel Strength in Shear:** The nominal static strength of a single anchor in shear as governed by the steel,  $V_{sa}$ , in accordance with ACI 318-19 17.7.1.2, ACI 318-14 17.5.1.2 or ACI 318-11 D.6.1.2, as applicable and strength reduction factors,  $\phi$ , in accordance with ACI 318-19 17.5.3, ACI 318-14 17.3.3 or ACI 318-11 D.4.3, as applicable, are given in the tables outlined in Table 1 for the anchor element types included in this report.

**4.1.6 Static Concrete Breakout Strength in Shear:** The nominal static concrete breakout strength of a single anchor or group of anchors in shear,  $V_{cb}$  or  $V_{cbg}$ , must be calculated in accordance with ACI 318-19 17.7.2, ACI 318-14 17.5.2 or ACI 318-11 D.6.2, as applicable, based on information given in the tables outlined in Table 1. The basic concrete breakout strength of a single anchor in shear,  $V_b$ , must be calculated in accordance with ACI 318-19 17.7.2.2, ACI 318-14 17.5.2.2 or ACI 318-11 D.6.2.2, as applicable, using the values of  $d$  given in the tables as outlined in Table 1 for the corresponding anchor steel in lieu of  $d_a$  (2021, 2018, 2015, and 2012 IBC). In addition,  $h_{ef}$  must be substituted for  $\ell_e$ . In no case must  $\ell_e$  exceed  $8d$ . The value of  $f'_c$  must be limited to a maximum of 8,000 psi (55 MPa) in accordance with ACI 318-19 17.3.1, ACI 318-14 17.2.7 or ACI 318-11 D.3.7, as applicable.

**4.1.7 Static Concrete Pryout Strength in Shear:** The nominal static pryout strength of a single anchor or group of anchors in shear,  $V_{cp}$  or  $V_{cpg}$ , must be calculated in accordance with ACI 318-19 17.7.3, ACI 318-14 17.5.3 or ACI 318-11 D.6.3, as applicable.

**4.1.8 Interaction of Tensile and Shear Forces:** For designs that include combined tension and shear, the interaction of tension and shear loads must be calculated in accordance with ACI 318-19 17.8, ACI 318-14 17.6 or ACI 318-11 D.7, as applicable.

**4.1.9 Minimum Member Thickness,  $h_{min}$ , Anchor Spacing,  $s_{min}$  and Edge Distance,  $c_{min}$ :**

**4.1.9.1 Hilti HIT-Z and HIT-Z-R Anchor Rods:** In lieu of ACI 318-19 17.9.2, ACI 318-14 17.7.1 and 17.7.3 or ACI 318-11 D.8.1 and D.8.3, as applicable, values of  $s_{min}$  and  $c_{min}$  described in Table 9 of this report must be observed for anchor design and installation. The minimum member thicknesses,  $h_{min}$ , given in Table 9 of this report must be observed for anchor design and installation.

**4.1.9.2 Threaded Rod, Steel Reinforcing Bars, and Hilti HIS-N and HIS-RN Inserts:** In lieu of ACI 318-19 17.9.2, ACI 318-14 17.7.1 and 17.7.3 or ACI 318-11 D.8.1 and D.8.3, as applicable, values of  $c_{min}$  and  $s_{min}$  described in this report must be observed for anchor design and installation. Likewise, in lieu of ACI 318-19 17.9.4, ACI 318-14 17.7.5 or ACI 318-11 D.8.5, as applicable, the minimum member thicknesses,  $h_{min}$ , described in this report must be observed for anchor design and installation. For adhesive anchors that will remain untorqued, ACI 318-19 17.9.3, ACI 318-14 17.7.4 or ACI 318-11 D.8.4, as applicable, applies.

For edge distances  $c_{ai}$  and anchor spacing  $s_{ai}$ , the maximum torque  $T_{max}$  shall comply with the following requirements:

REDUCED MAXIMUM INSTALLATION TORQUE $T_{max,red}$ FOR EDGE DISTANCES $c_{ai} < (5 \times d_a)$		
EDGE DISTANCE, $c_{ai}$	MINIMUM ANCHOR SPACING, $s_{ai}$	MAXIMUM TORQUE, $T_{max,red}$
1.75 in. (45 mm) $\leq c_{ai} < 5 \times d_a$	$5 \times d_a \leq s_{ai} < 16$ in.	$0.3 \times T_{max}$
	$s_{ai} \geq 16$ in. (406 mm)	$0.5 \times T_{max}$

**4.1.10 Critical Edge Distance  $c_{ac}$  and  $\psi_{cp,Na}$ :**

**4.1.10.1 Hilti HIT-Z and HIT-Z-R Anchor Rods:** In lieu of ACI 318-19 17.9.5, ACI 318-14 17.7.6 or ACI 318-11 D.8.6, as applicable, for the calculation of  $N_{cb}$  and  $N_{cbg}$  in accordance with ACI 318-19 17.6.2.6.1, ACI 318-14 17.4.2.7 or ACI 318-11 D.5.2.7, as applicable and Section 4.1.3 of this report, the critical edge distance,  $c_{ac}$ , must be determined as follows:

- i.  $c_{ac} = 1.5 \cdot h_{ef}$  for  $h/h_{ef} \geq 2.35$
- ii.  $c_{ac} = 3.5 \cdot h_{ef}$  for  $h/h_{ef} \leq 1.35$

For definitions of  $h$  and  $h_{ef}$ , see Figure 1.

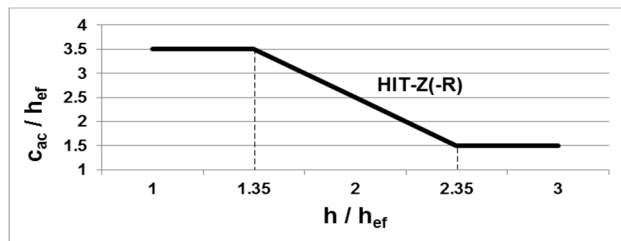

Linear interpolation is permitted to determine the ratio of  $c_{ac}/h_{ef}$  for values of  $h/h_{ef}$  between 2.35 and 1.35 as illustrated in the graph above.

**4.1.10.2 Threaded Rod, Steel Reinforcing Bars, and Hilti HIS-N and HIS-RN Inserts:** The modification factor  $\psi_{cp,Na}$ , must be determined in accordance with ACI 318-19 17.6.5.5, ACI 318-14 17.4.5.5 or ACI 318-11 D.5.5.5, as applicable, except as noted below:

For all cases where  $c_{Na}/c_{ac} < 1.0$ ,  $\psi_{cp,Na}$  determined from ACI 318-19 Eq. 17.6.5.5.1b, ACI 318-14 Eq. 17.4.5.5b or

ACI 318-11 Eq. D-27, as applicable, need not be taken less than  $c_{Na}/c_{ac}$ . For all other cases,  $\psi_{cp,Na}$  shall be taken as 1.0.

The critical edge distance,  $c_{ac}$  must be calculated according Eq. 17.6.5.5.1c for ACI 318-19, to Eq. 17.4.5.5c for ACI 318-14 or Eq. D-27a for ACI 318-11, in lieu of ACI 318-19 17.9.5, ACI 318-14 17.7.6 or ACI 318-11 D.8.6, as applicable.

$$c_{ac} = h_{ef} \cdot \left( \frac{\tau_{k,uncr}}{1160} \right)^{0.4} \cdot \left[ 3.1 - 0.7 \frac{h}{h_{ef}} \right]$$

(Eq. 17.6.5.5.1c for ACI 318-19, Eq. 17.4.5.5c for ACI 318-14 or Eq. D-27a for ACI 318-11)

where

$\left[ \frac{h}{h_{ef}} \right]$  need not be taken as larger than 2.4; and

$\tau_{k,uncr}$  is the characteristic bond strength in uncracked concrete,  $h$  is the member thickness, and  $h_{ef}$  is the embedment depth.

$\tau_{k,uncr}$  need not be taken as greater than:

$$\tau_{k,uncr} = \frac{k_{uncr} \sqrt{h_{ef}^2 c}}{\pi d} \quad \text{Eq. (4-1)}$$

**4.1.11 Design Strength in Seismic Design Categories C, D, E and F:** In structures assigned to Seismic Design Category C, D, E or F under the IBC or IRC, anchors must be designed in accordance with ACI 318-19 17.10, ACI 318-14 17.2.3 or ACI 318-11 D.3.3, as applicable, except as described below:

Modifications to ACI 318-19 17.10 and ACI 318-14 17.2.3 shall be applied under Section 1905.1.8 of the 2021, 2018 and 2015 IBC, as applicable. For the 2012 IBC, Section 19.5.1.9 shall be omitted. The nominal steel shear strength,  $V_{sa}$ , must be adjusted by  $\alpha_{V,seis}$  as given in the tables summarized in Table 1 for the anchor element types included in this report. For tension, the nominal pullout strength  $N_{p,cr}$  or bond strength  $\tau_{cr}$  must be adjusted by  $\alpha_{N,seis}$ . See Tables 10, 13, 14, 15, 16, 19, 20, 21, 22, 25, 26 and 29.

As an exception to ACI 318-11 D.3.3.4.2:

Anchors designed to resist wall out-of-plane forces with design strengths equal to or greater than the force determined in accordance with ASCE 7 Equation 12.11-1 or 12.14-10 shall be deemed to satisfy ACI 318-11 D.3.3.4.3(d). Under ACI 318-11 D.3.3.4.3(d), in lieu of requiring the anchor design tensile strength to satisfy the tensile strength requirements of ACI 318-11 D.4.1.1, the anchor design tensile strength shall be calculated from ACI 318-11 D.3.3.4.4.

The following exceptions apply to ACI 318-11 D.3.3.5.2:

1. For the calculation of the in-plane shear strength of anchor bolts attaching wood sill plates of bearing or non-bearing walls of light-frame wood structures to foundations or foundation stem walls, the in-plane shear strength in accordance with ACI 318-11 D.6.2 and D.6.3 need not be computed and ACI 318-11 D.3.3.5.3 need not apply provided all of the following are satisfied:

- 1.1. The allowable in-plane shear strength of the anchor is determined in accordance with AF&PA NDS Table 11E for lateral design values parallel to grain.
- 1.2. The maximum anchor nominal diameter is  $5/8$  inch (16 mm).
- 1.3. Anchor bolts are embedded into concrete a minimum of 7 inches (178 mm).
- 1.4. Anchor bolts are located a minimum of  $1 3/4$  inches (45 mm) from the edge of the concrete parallel to the length of the wood sill plate.

1.5. Anchor bolts are located a minimum of 15 anchor diameters from the edge of the concrete perpendicular to the length of the wood sill plate.

1.6. The sill plate is 2-inch or 3-inch nominal thickness.

2. For the calculation of the in-plane shear strength of anchor bolts attaching cold-formed steel track of bearing or non-bearing walls of light-frame construction to foundations or foundation stem walls, the in-plane shear strength in accordance with ACI 318-11 D.6.2 and D.6.3, need not be computed and ACI 318-11 D.3.3.5.3 need not apply provided all of the following are satisfied:

2.1. The maximum anchor nominal diameter is  $5/8$  inch (16 mm).

2.2. Anchors are embedded into concrete a minimum of 7 inches (178 mm).

2.3. Anchors are located a minimum of  $1\ 3/4$  inches (45 mm) from the edge of the concrete parallel to the length of the track.

2.4. Anchors are located a minimum of 15 anchor diameters from the edge of the concrete perpendicular to the length of the track.

2.5. The track is 33 to 68 mil designation thickness.

Allowable in-plane shear strength of exempt anchors, parallel to the edge of concrete shall be permitted to be determined in accordance with AISI S100 Section E3.3.1.

3. In light-frame construction, bearing or nonbearing walls, shear strength of concrete anchors less than or equal to 1 inch [25 mm] in diameter attaching a sill plate or track to foundation or foundation stem wall need not satisfy ACI 318-11 D.3.3.5.3(a) through (c) when the design strength of the anchors is determined in accordance with ACI 318-11 D.6.2.1(c).

## 4.2 Strength Design of Post-Installed Reinforcing Bars:

**4.2.1 General:** The design of straight post-installed deformed reinforcing bars must be determined in accordance with ACI 318 rules for cast-in place reinforcing bar development and splices and this report.

Examples of typical applications for the use of post-installed reinforcing bars are illustrated in Figure 3 of this report.

**4.2.2 Determination of bar development length  $l_d$ :** Values of  $l_d$  must be determined in accordance with the ACI 318 development and splice length requirements for straight cast-in place reinforcing bars.

### Exceptions:

1. For uncoated and zinc-coated (galvanized) post-installed reinforcing bars, the factor  $\Psi_e$  shall be taken as 1.0. For all other cases, the requirements in ACI 318-19 25.4.2.5, ACI 318-14 25.4.2.4 or ACI 318-11 Section 12.2.4 (b) shall apply.

2. When using alternate methods to calculate the development length (e.g., anchor theory), the applicable factors for post-installed anchors generally apply.

**4.2.3 Minimum Member Thickness,  $h_{min}$ , Minimum Concrete Cover,  $C_{c,min}$ , Minimum Concrete Edge Distance,  $C_{b,min}$ , Minimum Spacing,  $s_{b,min}$ :** For post-installed reinforcing bars, there is no limit on the minimum member thickness. In general, all requirements on concrete cover and spacing applicable to straight cast-in bars designed in accordance with ACI 318 shall be maintained.

For post-installed reinforcing bars installed at embedment depths,  $h_{ef}$ , larger than  $20d$  ( $h_{ef} > 20d$ ), the minimum concrete cover shall be as follows:

REBAR SIZE	MINIMUM CONCRETE COVER, $C_{c,min}$
$d_b \leq \text{No. 6 (16mm)}$	$1\ 3/16 \text{ in. (30mm)}$
$\text{No. 6} < d_b \leq \text{No. 10 (16mm} < d_b \leq 32\text{mm)}$	$1\ 9/16 \text{ in. (40mm)}$

The following requirements apply for minimum concrete edge and spacing for  $h_{ef} > 20d$ :

Required minimum edge distance for post-installed reinforcing bars (measured from the center of the bar):

$$C_{b,min} = d_o/2 + C_{c,min}$$

Required minimum center-to-center spacing between post-installed bars:

$$S_{b,min} = d_o + C_{c,min}$$

Required minimum center-to-center spacing from existing (parallel) reinforcing:

$$S_{b,min} = d_b/2 \text{ (existing reinforcing)} + d_o/2 + C_{c,min}$$

**4.2.4 Design Strength in Seismic Design Categories C, D, E and F:** In structures assigned to Seismic Category C, D, E or F under the IBC or IRC, design of straight post-installed reinforcing bars must take into account the provisions of ACI 318-19 or ACI 318-14 Chapter 18 or ACI 318-11 Chapter 21, as applicable.

## 4.3 Installation:

Installation parameters are illustrated in Figure 1. Installation must be in accordance with ACI 318-19 26.7.2, ACI 318-14 17.8.1 and 17.8.2 or ACI 318-11 D.9.1 and D.9.2, as applicable. Anchor and post-installed reinforcing bar locations must comply with this report and the plans and specifications approved by the code official. Installation of the Hilti HIT-HY 200 V3 Adhesive Anchor and Post-Installed Reinforcing Bar Systems must conform to the manufacturer's printed installation instructions (MPII) included in each unit package as provided in Figure 6 of this report. The MPII contains additional requirements for combinations of drill hole depth, diameter, drill bit type, and dispensing tools.

## 4.4 Special Inspection:

Periodic special inspection must be performed where required in accordance with Section 1705.1.1 and Table 1705.3 of the 2021, 2018, 2015 and 2012 IBC, and this report. The special inspector must be on the jobsite initially during anchor or post-installed reinforcing bar installation to verify anchor or post-installed reinforcing bar type and dimensions, concrete type, concrete compressive strength, adhesive identification and expiration date, hole dimensions, hole cleaning procedures, spacing, edge distances, concrete thickness, anchor or post-installed reinforcing bar embedment, tightening torque and adherence to the manufacturer's printed installation instructions.

The special inspector must verify the initial installations of each type and size of adhesive anchor or post-installed reinforcing bar by construction personnel on site. Subsequent installations of the same anchor or post-installed reinforcing bar type and size by the same construction personnel are permitted to be performed in the absence of the special inspector. Any change in the anchor or post-installed reinforcing bar product being installed or the personnel performing the installation requires an initial inspection. For ongoing installations over an extended period, the special inspector must make regular inspections to confirm correct handling and installation of the product.

Continuous special inspection of adhesive anchors or post-installed reinforcing bar installed in horizontal or upwardly inclined orientations to resist sustained tension loads shall be performed in accordance with ACI 318-19 26.13.3.2e and 26.7.1(j), ACI 318-14 17.8.2.4, 26.7.1(h), and 26.13.3.2(c) or ACI 318-11 D.9.2.4, as applicable.

Under the IBC, additional requirements as set forth in Sections 1705, 1706, and 1707 must be observed, where applicable.

## 5.0 CONDITIONS OF USE

The Hilti HIT-HY 200 V3 Adhesive Anchor System and Post-Installed Reinforcing Bar System described in this report complies with, or is a suitable alternative to what is specified in, the codes listed in Section 1.0 of this report, subject to the following conditions:

- 5.1 Hilti HIT-HY 200 V3 Adhesive anchors and post-installed reinforcing bars must be installed in accordance with the manufacturer's printed installation instructions (MPII) as included in the adhesive packaging and provided in Figure 6 of this report.
- 5.2 The anchors and post-installed reinforcing bars must be installed in cracked and uncracked normal-weight or lightweight concrete having a specified compressive strength  $f'_c = 2,500$  psi to 8,500 psi (17.2 MPa to 58.6 MPa).
- 5.3 The values of  $f'_c$  used for calculation purposes must not exceed 8,000 psi (55.1 MPa) except as noted in Sections 4.2.2 and 4.2.4 of this report.
- 5.4 The concrete shall have attained its minimum design strength prior to installation of the adhesive anchors.
- 5.5 Anchors and post-installed reinforcing bars must be installed in concrete base materials in holes predrilled in accordance with the instructions in Figure 6, using carbide-tipped masonry drill bits manufactured with the range of maximum and minimum drill-tip dimensions specified in ANSI B212.15-1994. The Hilti HIT-Z(-R) anchor rods may be installed in holes predrilled using diamond core drill bits. Threaded rods, reinforcing bars, and the Hilti HIS-(R)N inserts may be installed in holes predrilled using diamond core bits and roughened with the Hilti TE-YRT roughening tool as detailed in Figure 6.
- 5.6 Loads applied to the anchors must be adjusted in accordance with Section 1605.1 of the 2021 IBC or Section 1605.2 of the 2018, 2015 and 2012 IBC for strength design and in accordance with Section 1605.1 of the 2021 IBC or Section 1605.3 of the 2018, 2015, and 2012 IBC for allowable stress design.
- 5.7 Hilti HIT-HY 200 V3 adhesive anchors and post-installed reinforcing bars are recognized for use to resist short- and long-term loads, including wind and earthquake, subject to the conditions of this report.
- 5.8 In structures assigned to Seismic Design Category C, D, E or F under the IBC or IRC, anchor strength must be adjusted in accordance with Section 4.1.11 of this report, and post-installed reinforcing bars must comply with section 4.2.4 of this report.
- 5.9 Hilti HIT-HY 200 V3 adhesive anchors and post-installed reinforcing bars are permitted to be installed in concrete that is cracked or that may be expected to crack during the service life of the anchor, subject to the conditions of this report.
- 5.10 Anchor strength design values must be established in accordance with Section 4.1 of this report.
- 5.11 Post-installed reinforcing bar development and splice length is established in accordance with Section 4.2 of this report.
- 5.12 Minimum anchor spacing and edge distance as well as minimum member thickness must comply with the values noted in this report.
- 5.13 Post-installed reinforcing bar spacing, minimum member thickness, and cover distance must be in accordance with the provisions of ACI 318 for cast-in place bars and section 4.2.3 of this report.
- 5.14 Prior to anchor installation, calculations and details demonstrating compliance with this report must be submitted to the code official. The calculations and details must be prepared by a registered design professional where required by the statutes of the jurisdiction in which the project is to be constructed.
- 5.15 Anchors and post-installed reinforcing bars are not permitted to support fire-resistive construction. Where not otherwise prohibited by the code, Hilti HIT-HY 200 V3 adhesive anchors and post-installed reinforcing bars are permitted for installation in fire-resistive construction provided that at least one of the following conditions is fulfilled:
  - Anchors and post-installed reinforcing bars are used to resist wind or seismic forces only.
  - Anchors and post-installed reinforcing bars that support gravity load-bearing structural elements are within a fire-resistive envelope or a fire-resistive membrane, are protected by approved fire-resistive materials, or have been evaluated for resistance to fire exposure in accordance with recognized standards.
  - Anchors and post-installed reinforcing bars are used to support nonstructural elements.
- 5.16 Since an ICC-ES acceptance criteria for evaluating data to determine the performance of adhesive anchors and post-installed reinforcing bars subjected to fatigue or shock loading is unavailable at this time, the use of these anchors under such conditions is beyond the scope of this report.
- 5.17 Use of zinc-plated carbon steel threaded rods or steel reinforcing bars is limited to dry, interior locations.
- 5.18 Use of hot-dipped galvanized carbon steel and stainless steel rods is permitted for exterior exposure or damp environments.
- 5.19 Steel anchoring materials in contact with preservative-treated and fire-retardant-treated wood must be of zinc-coated carbon steel or stainless steel. The minimum coating weights for zinc-coated steel must comply with ASTM A153.
- 5.20 Periodic special inspection must be provided in accordance with Section 4.4 of this report. Continuous special inspection for anchors and post-installed reinforcing bars installed in horizontal or upwardly inclined orientations to resist sustained tension loads must be provided in accordance with Section 4.4 of this report.
- 5.21 Installation of anchors and post-installed reinforcing bars in horizontal or upwardly inclined orientations to resist sustained tension loads shall be performed by personnel certified by an applicable certification program in accordance with ACI 318-19 26.7.2(e), ACI 318-14 17.8.2.2 or 17.8.2.3, or ACI 318-11 D.9.2.2 or D.9.2.3, as applicable.

**5.22** Hilti HIT-HY 200 V3 adhesive anchors and post-installed reinforcing bars may be used to resist tension and shear forces in floor, wall, and overhead installations only if installation is into concrete with a temperature between 14°F and 104°F (-10°C and 40°C) for threaded rods, rebar, and Hilti HIS-(R)N inserts, or between 41°F and 104°F (5°C and 40°C) for Hilti HIT-Z(-R) anchor rods. (For post-installed reinforcing bars with embedment depth greater than 20d refer to additional temperature limitations in the MPII as provided in Figure 6 of this report). Overhead installations for hole diameters larger than  $\frac{7}{16}$ -inch or 10mm require the use of piston plugs (HIT-SZ, -IP) during injection to the back of the hole.  $\frac{7}{16}$ -inch diameter holes may be injected directly to the back of the hole with the use of extension tubing on the end of the nozzle. The anchor or post-installed reinforcing bars must be supported until fully cured (i.e., with Hilti HIT-OHW wedges, or other suitable means). Where temporary restraint devices are used, their use shall not result in impairment of the anchor shear resistance. Installations in concrete temperatures below 32°F require the adhesive to be conditioned to a minimum temperature of 32°F.

**5.23** Anchors and post-installed reinforcing bars when installed at temperatures below 40°F shall not be used for applications where the concrete temperature can rise from 40°F or less to 80°F or higher within a 12-hour period. Such applications may include, but are not limited to, anchorage of building façade systems and other applications subject to direct sun exposure.

**5.24** Hilti HIT-HY 200-A V3 and Hilti HIT-HY 200-R V3 adhesives are manufactured by Hilti GmbH, Kaufering, Germany, under a quality control program with inspections by ICC-ES.

**5.25** Hilti HIT-Z and HIT-Z-R rods are manufactured by Hilti AG, Schaan, Liechtenstein, under a quality-control program with inspections by ICC-ES.

**5.26** Hilti HIS-N and HIS-RN inserts are manufactured by Hilti (China) Ltd., Guangdong, China, under a quality-control program with inspections by ICC-ES.

## 6.0 EVIDENCE SUBMITTED

Data in accordance with the ICC-ES Acceptance Criteria for Post-installed Adhesive Anchors in Concrete Elements (AC308), dated June 2019, editorially revised February 2021, which incorporates requirements in ACI 355.4-11 and ACI 355.4-19, and Table 3.8 for evaluating post-installed reinforcing bars.

## 7.0 IDENTIFICATION

**7.1** Product labeling shall include, the name of the report holder or listee, and the ICC-ES mark of conformity. The listing or evaluation report number (ICC-ES ESR-4868) may be used in lieu of the mark of conformity. Hilti HIT-HY 200 A V3 and Hilti HIT HY 200 R V3 adhesive is identified by packaging labeled with the manufacturer's name (Hilti Corp.) and address, product name, lot number, expiration date, and evaluation report number (ESR-4868).

**7.2** Hilti HIT-Z and HIT-Z-R rods are identified by packaging labeled with the manufacturer's name (Hilti Corp.) and address, anchor name, and evaluation report number (ESR-4868).

**7.3** Hilti HIS-N and HIS-RN inserts are identified by packaging labeled with the manufacturer's name (Hilti Corp.) and address, anchor name and size, and evaluation report number (ESR-4868).

**7.4** Threaded rods, nuts, washers, bolts, cap screws, and deformed reinforcing bars are standard elements and must conform to applicable national or international specifications.

**7.5** The report holder's contact information is the following:

**HILTI, INC.**  
**7250 DALLAS PARKWAY, SUITE 1000**  
**PLANO, TEXAS 75024**  
**(800) 879-8000**  
[www.hilti.com](http://www.hilti.com)  
[HiltiTechEng@us.hilti.com](mailto:HiltiTechEng@us.hilti.com)

**HILTI HIT-Z AND HIT-Z-R ANCHOR ROD**

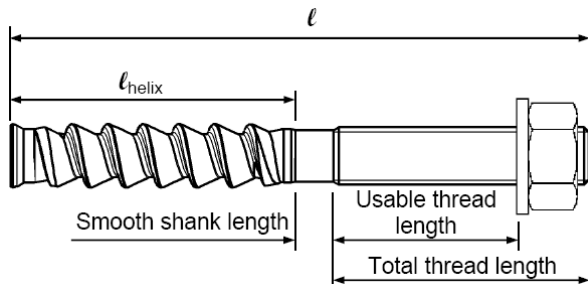
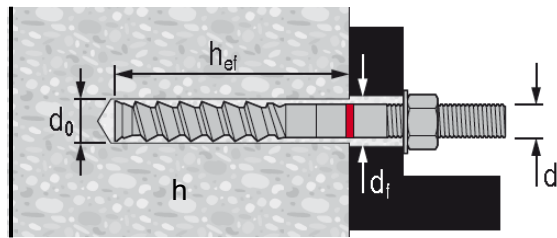

**FRACTIONAL HIT-Z AND HIT-Z-R ANCHOR ROD**

Ø d [inch]	Ø d <sub>0</sub> [inch]	h <sub>ef</sub> [inch]	T <sub>inst</sub> [ft-lb]		T <sub>inst</sub> [Nm]	
			HIT-Z	HIT-Z-R	HIT-Z	HIT-Z-R
3/8	7/16	2 3/8 ... 4 1/2	15	30	20	40
1/2	9/16	2 3/4 ... 6	30	65	40	90
5/8	3/4	3 3/4 ... 7 1/2	60	125	80	170
3/4	7/8	4 ... 8 1/2	110	165	150	220

**METRIC HIT-Z AND HIT-Z-R ANCHOR ROD**

Ø d [mm]	Ø d <sub>0</sub> [mm]	h <sub>nom</sub> [mm]	T <sub>inst</sub> [Nm]	
			HIT-Z	HIT-Z-R
M10	12	60...120	25	55
M12	14	70...144	40	75
M16	18	96...192	80	155
M20	22	100...220	150	215

Name and Size	l Anchor Length		l <sub>helix</sub> Helix Length		Smooth Shank Length		Total Thread Length		Usable Thread Length	
	in	(mm)	in	(mm)	in	(mm)	In	(mm)	in	(mm)
HIT-Z(-R) 3/8" x 3 3/8"	3 3/8	(85)	2 1/4	(57)	3/8	(6)	1 3/16	(21)	5/16	(8)
HIT-Z(-R) 3/8" x 4 3/8"	4 3/8	(111)	2 1/4	(57)	5/16	(8)	1 13/16	(46)	1 5/16	(33)
HIT-Z(-R) 3/8" x 5 1/8"	5 1/8	(130)	2 1/4	(57)	5/16	(8)	2 9/16	(65)	2 1/16	(52)
HIT-Z(-R) 3/8" x 6 3/8"	6 3/8	(162)	2 1/4	(57)	5/16	(8)	3 13/16	(97)	3 5/16	(84)
HIT-Z(-R) 1/2" x 4 1/2"	4 1/2	(114)	2 1/2	(63)	5/16	(8)	1 11/16	(43)	1	(26)
HIT-Z(-R) 1/2" x 6 1/2"	6 1/2	(165)	2 1/2	(63)	5/16	(8)	3 11/16	(94)	3 1/16	(77)
HIT-Z(-R) 1/2" x 7 3/4"	7 3/4	(197)	2 1/2	(63)	5/16	(8)	4 15/16	(126)	4 5/16	(109)
HIT-Z(-R) 5/8" x 6"	6	(152)	3 5/8	(92)	7/16	(11)	1 15/16	(49)	1 1/8	(28)
HIT-Z(-R) 5/8" x 8"	8	(203)	3 5/8	(92)	7/16	(11)	3 15/16	(100)	3 1/8	(79)
HIT-Z(-R) 5/8" x 9 1/2"	9 1/2	(241)	3 5/8	(92)	1 15/16	(49)	3 15/16	(100)	3 1/8	(79)
HIT-Z(-R) 3/4" x 6 1/2"	6 1/2	(165)	4	(102)	5/16	(8)	2	(51)	1	(26)
HIT-Z(-R) 3/4" x 8 1/2"	8 1/2	(216)	4	(102)	7/16	(12)	4	(102)	3 1/16	(77)
HIT-Z(-R) 3/4" x 9 3/4"	9 3/4	(248)	4	(102)	1 11/16	(44)	4	(102)	3 1/16	(77)
HIT-Z(-R) M10x95	3 3/4	(95)	1 15/16	(50)	1 1/16	(18)	1 1/8	(27)	9/16	(14)
HIT-Z(-R) M10x115	4 1/2	(115)	1 15/16	(50)	1 1/16	(18)	1 7/8	(47)	1 5/16	(34)
HIT-Z(-R) M10x135	5 5/16	(135)	1 15/16	(50)	1 1/16	(18)	2 5/8	(67)	2 1/8	(54)
HIT-Z(-R) M10x160	6 5/16	(160)	1 15/16	(50)	1 1/16	(18)	3 5/8	(92)	3 1/8	(79)
HIT-Z(-R) M12x105	4 1/8	(105)	2 3/8	(60)	5/16	(8)	1 1/2	(37)	1 3/16	(21)
HIT-Z(-R) M12x140	5 1/2	(140)	2 3/8	(60)	5/16	(8)	2 7/8	(72)	2 3/16	(56)
HIT-Z(-R) M12x155	6 1/8	(155)	2 3/8	(60)	5/16	(8)	3 3/8	(87)	2 13/16	(71)
HIT-Z(-R) M12x196	7 3/4	(196)	2 3/8	(60)	5/16	(8)	5	(128)	4 7/16	(112)
HIT-Z(-R) M16x155	6 1/8	(155)	3 11/16	(93)	7/16	(11)	2	(51)	1 3/16	(30)
HIT-Z(-R) M16x175	6 7/8	(175)	3 11/16	(93)	7/16	(11)	2 13/16	(71)	1 15/16	(50)
HIT-Z(-R) M16x205	8 1/16	(205)	3 11/16	(93)	7/16	(11)	4	(101)	3 1/8	(80)
HIT-Z(-R) M16x240	9 7/16	(240)	3 11/16	(93)	1 1/4	(32)	4 1/2	(115)	3 11/16	(94)
HIT-Z(-R) M20x215	8 1/2	(215)	3 15/16	(100)	1/2	(13)	4	(102)	3 1/16	(78)
HIT-Z(-R) M20x250	9 13/16	(250)	3 15/16	(100)	1 7/8	(48)	4	(102)	3 1/16	(78)

**FIGURE 1—INSTALLATION PARAMETERS FOR POST-INSTALLED ADHESIVE ANCHORS**



**DEFORMED REINFORCEMENT**

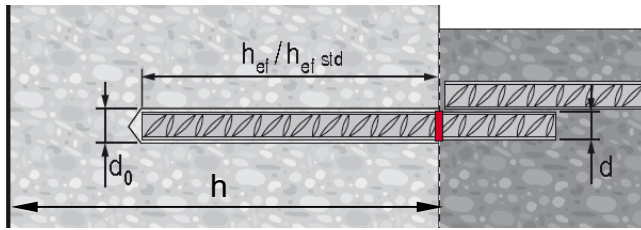

**US REBAR**

d	Ø d <sub>0</sub> [inch]	h <sub>ef</sub> std [inch]	h <sub>ef</sub> [inch]
#3	1/2	3 3/8	2 3/8...7 1/2
#4	5/8	4 1/2	2 3/4...10
#5	3/4	5 3/8	3 1/8...12 1/2
#6	7/8	6 3/4	3 1/2...15
#7	1	7 7/8	3 1/2...17 1/2
#8	1 1/8	9	4...20
#9	1 3/8	10 1/8	4 1/2...22 1/2
#10	1 1/2	11 1/4	5...25

**CANADIAN REBAR**

d	Ø d <sub>0</sub> [inch]	h <sub>ef</sub> std [mm]	h <sub>ef</sub> [mm]
10 M	9/16	115	70...226
15 M	3/4	145	80...320
20 M	1	200	90...390
25 M	1 1/4	230	101...504
30 M	1 1/2	260	120...598

**EUROPEAN REBAR**

Ø d [mm]	Ø d <sub>0</sub> [mm]	h <sub>ef</sub> std [mm]	h <sub>ef</sub> [mm]
10	14	90	60...200
12	16	110	70...240
14	18	125	75...280
16	20	125	80...320
20	25	170	90...400
25	32	210	100...500
28	35	270	112...560
32	40	300	128...640

**THREADED ROD**

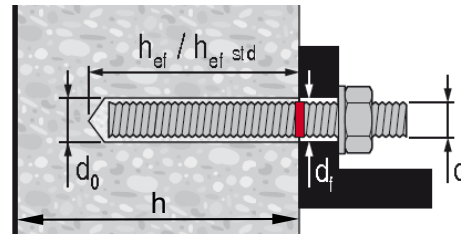

**FRACTIONAL THREADED ROD**

Ø d [inch]	Ø d <sub>0</sub> [inch]	h <sub>ef</sub> std [inch]	h <sub>ef</sub> [inch]	T <sub>max</sub> [ft-lb]	T <sub>max</sub> [Nm]
3/8	7/16	3 3/8	2 3/8...7 1/2	15	20
1/2	9/16	4 1/2	2 3/4...10	30	41
5/8	3/4	5 5/8	3 1/8...12 1/2	60	81
3/4	7/8	6 3/4	3 1/2...15	100	136
7/8	1	7 7/8	3 1/2...17 1/2	125	169
1	1 1/8	9	4...20	150	203
1 1/4	1 3/8	11 1/4	5...25	200	271

**METRIC THREADED ROD**

Ø d [mm]	Ø d <sub>0</sub> [mm]	h <sub>ef</sub> std [mm]	h <sub>ef</sub> [mm]	T <sub>max</sub> [Nm]
M10	12	90	60...200	20
M12	14	110	70...240	40
M16	18	125	80...320	80
M20	22	170	90...400	150
M24	28	210	96...480	200
M27	30	240	108...540	270
M30	35	270	120...600	300

**HILTI HIS-N AND HIS-RN THREADED INSERTS**

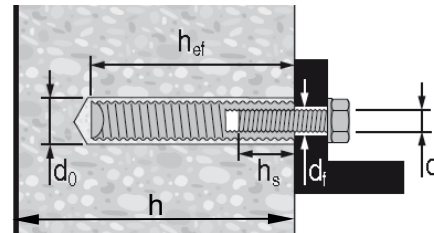

**FRACTIONAL HILTI HIS-N AND HIS-RN THREADED INSERTS**

Ø d [inch]	Ø d <sub>0</sub> [inch]	h <sub>ef</sub> [inch]	Ø d <sub>i</sub> [inch]	h <sub>s</sub> [inch]	T <sub>max</sub> [ft-lb]	T <sub>max</sub> [Nm]
3/8	1 1/16	4 3/8	7/16	3/8...1 5/16	15	20
1/2	7/8	5	9/16	1/2...1 3/16	30	41
5/8	1 1/8	6 3/4	1 1/16	5/8...1 1/2	60	81
3/4	1 1/4	8 1/8	1 3/16	3/4...1 7/8	100	136

**METRIC HILTI HIS-N AND HIS-RN THREADED INSERTS**

Ø d [mm]	Ø d <sub>0</sub> [mm]	h <sub>ef</sub> [mm]	Ø d <sub>i</sub> [mm]	h <sub>s</sub> [mm]	T <sub>max</sub> [Nm]
M8	14	90	9	8...20	10
M10	18	110	12	10...25	20
M12	22	125	14	12...30	40
M16	28	170	18	16...40	80
M20	32	205	22	20...50	150

FIGURE 1—INSTALLATION PARAMETERS FOR POST INSTALLED ADHESIVE ANCHORS (Continued)

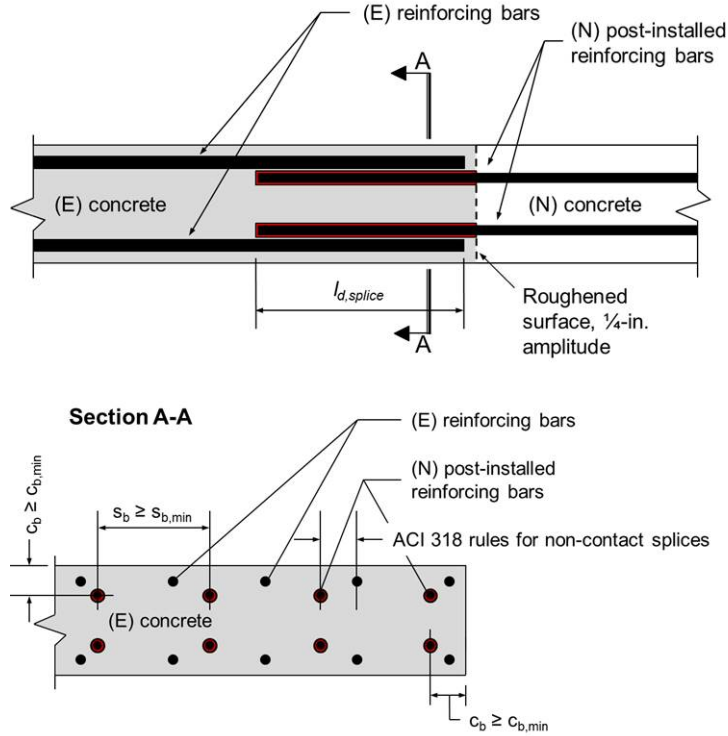

FIGURE 2—INSTALLATION PARAMATERS FOR POST-INSTALLED REINFORCING BARS

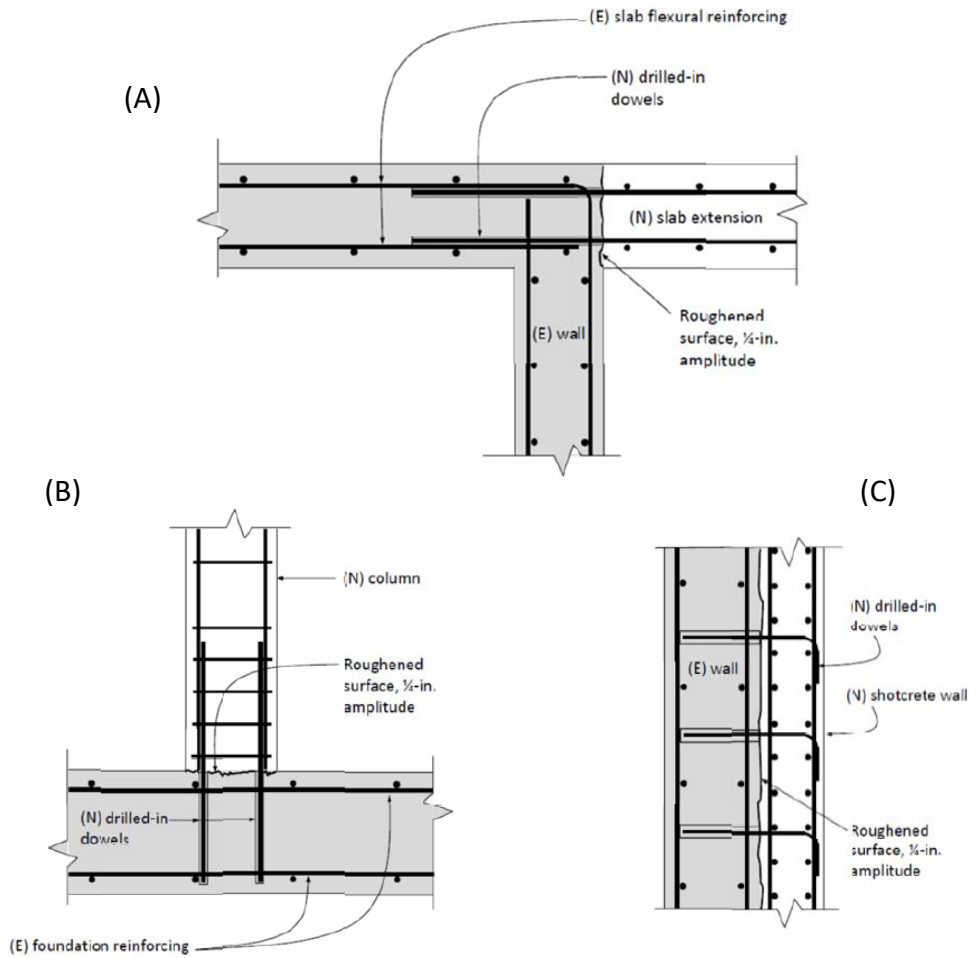







FIGURE 3—APPLICATION EXAMPLES FOR POST-INSTALLED REINFORCING BARS:  
 (A) TENSION LAP SPLICE WITH EXISTING FLEXURAL REINFORCEMENT; (B) TENSION DEVELOPMENT OF COLUMN DOWELS;  
 (C) DEVELOPMENT OF SHEAR DOWELS FOR NEWLY THICKENED SHEAR WALL

TABLE 1—DESIGN TABLE INDEX

Design Table		Fractional		Metric			
		Table	Page	Table	Page		
 <b>Hilti HIT-Z and HIT-Z-R Anchor Rod</b>	Steel Strength - $N_{sa}, V_{sa}$	7	14	7	14		
	Concrete Breakout - $N_{cb}, N_{cbg}, V_{cb}, V_{cbg}, V_{cp}, V_{cpg}$	8	15	8	15		
	Pullout Strength - $N_p$	10	19	10	19		
 <b>Standard Threaded Rod</b>	Steel Strength - $N_{sa}, V_{sa}$	11	20	17	27		
	Concrete Breakout - $N_{cb}, N_{cbg}, V_{cb}, V_{cbg}, V_{cp}, V_{cpg}$	12	22	18	28		
	Bond Strength - $N_a, N_{ag}$	15 & 16	25 & 26	21 & 22	31 & 32		
 <b>Hilti HIS-N and HIS-RN Internally Threaded Insert</b>	Steel Strength - $N_{sa}, V_{sa}$	27	36	27	36		
	Concrete Breakout - $N_{cb}, N_{cbg}, V_{cb}, V_{cbg}, V_{cp}, V_{cpg}$	28	37	28	37		
	Bond Strength - $N_a, N_{ag}$	29	38	29	38		
Design Table		Fractional		EU Metric		Canadian	
		Table	Page	Table	Page	Table	Page
 <b>Steel Reinforcing Bars</b>	Steel Strength - $N_{sa}, V_{sa}$	11A	21	17	27	23	33
	Concrete Breakout - $N_{cb}, N_{cbg}, V_{cb}, V_{cbg}, V_{cp}, V_{cpg}$	12	22	18	28	24	33
	Bond Strength - $N_a, N_{ag}$	13 & 14	23 & 24	19 & 20	29 & 30	25 & 26	34 & 35
	Determination of development length for post-installed reinforcing bar connections	30	39	31	40	32	40

**TABLE 2—SPECIFICATIONS AND PHYSICAL PROPERTIES OF FRACTIONAL AND METRIC HIT-Z AND HIT-Z RODS**

HIT-Z AND HIT-Z-R ROD SPECIFICATION			Minimum specified ultimate strength, $f_{uta}$	Minimum specified yield strength 0.2 percent offset, $f_{ya}$	$f_{uta}/f_{ya}$	Elongation, min. percent	Reduction of Area, min. percent	Specification for nuts <sup>2</sup>
CARBON STEEL								
	$\frac{3}{8}$ -in. to $\frac{5}{8}$ -in. and M10 to M12 - AISI 1038	psi	94,200	75,300	1.25	8	20	ASTM A563 Grade A
	$\frac{3}{4}$ -in. - AISI 1038 or 18MnV5	(MPa)	(650)	(520)				
M16 - AISI 1038	psi	88,400	71,000					
		(MPa)	(610)	(490)				
	M20 - AISI 1038 or 18MnV5	psi	86,200	69,600				
		(MPa)	(595)	(480)				
STAINLESS STEEL	$\frac{3}{8}$ -in. to $\frac{3}{4}$ -in. and M10 to M12 Grade 316 DIN-EN 10263-5 X5CrNiMo 17-12-2+AT	psi	94,200	75,300	1.25	8	20	ASTM F594 Type 316
	M16 Grade 316 DIN-EN 10263-5 X5CrNiMo 17-12-2+AT	psi	88,400	71,000				
		(MPa)	(610)	(490)				
	M20 Grade 316 DIN-EN 10263-5 X5CrNiMo 17-12-2+AT	psi	86,200	69,600				
		(MPa)	(595)	(480)				

<sup>1</sup> Steel properties are minimum values and maximum values will vary due to the cold forming of the rod.

<sup>2</sup> Nuts of other grades and styles having specified proof load stresses greater than the specified grade and style are also suitable. Nuts must have specified proof load stresses equal to or greater than the minimum tensile strength of the specified threaded rod.

**TABLE 3—SPECIFICATIONS AND PHYSICAL PROPERTIES OF COMMON CARBON AND STAINLESS STEEL THREADED ROD MATERIALS<sup>1</sup>**

THREADED ROD SPECIFICATION			Minimum specified ultimate strength, $f_{uta}$	Minimum specified yield strength 0.2 percent offset, $f_{ya}$	$f_{uta}/f_{ya}$	Elongation, min. percent <sup>7</sup>	Reduction of Area, min. percent	Specification for nuts <sup>8</sup>
CARBON STEEL								
	ASTM A193 <sup>2</sup> Grade B7 $\leq 2\frac{1}{2}$ in. ( $\leq 64$ mm)	psi	125,000	105,000	1.19	16	50	ASTM A563 Grade DH
		(MPa)	(862)	(724)				
	ASTM F568M <sup>3</sup> Class 5.8 M5 ( $\frac{1}{4}$ in.) to M24 (1 in.) (equivalent to ISO 898-1)	psi	72,500	58,000	1.25	10	35	ASTM A563 Grade DH <sup>9</sup> DIN 934 (8-A2K)
		(MPa)	(500)	(400)				
	ASTM F1554, Grade 36 <sup>7</sup>	psi	58,000	36,000	1.61	23	40	ASTM A194 or ASTM A563
		(MPa)	(400)	(248)				
ASTM F1554, Grade 55 <sup>7</sup>	psi	75,000	55,000	1.36	21	30	ASTM A194 or ASTM A563	
	(MPa)	(517)	(379)					
ASTM F1554, Grade 105 <sup>7</sup>	psi	125,000	105,000	1.19	15	45	ASTM A194 or ASTM A563	
	(MPa)	(862)	(724)					
ISO 898-1 <sup>4</sup> Class 5.8	MPa	500	400	1.25	22	-	DIN 934 Grade 6	
	(psi)	(72,500)	(58,000)					
ISO 898-1 <sup>4</sup> Class 8.8	MPa	800	640	1.25	12	52	DIN 934 Grade 8	
	(psi)	(116,000)	(92,800)					
STAINLESS STEEL	ASTM F593 <sup>5</sup> CW1 (316) $\frac{1}{4}$ -in. to $\frac{5}{8}$ -in.	psi	100,000	65,000	1.54	20	-	ASTM F594
		(MPa)	(689)	(448)				
	ASTM F593 <sup>5</sup> CW2 (316) $\frac{3}{4}$ -in. to $1\frac{1}{2}$ -in.	psi	85,000	45,000	1.89	25	-	ASTM F594
		(MPa)	(586)	(310)				
	ASTM A193 Grade 8(M), Class 1 <sup>2</sup> - $1\frac{1}{4}$ -in.	psi	75,000	30,000	2.50	30	50	ASTM F594
	(MPa)	(517)	(207)					
ISO 3506-1 <sup>6</sup> A4-70 M8 - M24	MPa	700	450	1.56	40	-	ISO 4032	
	(psi)	(101,500)	(65,250)					
ISO 3506-1 <sup>6</sup> A4-50 M27 - M30	MPa	500	210	2.38	40	-	ISO 4032	
	(psi)	(72,500)	(30,450)					

<sup>1</sup> Hilti HIT-HY 200 V3 adhesive may be used in conjunction with all grades of continuously threaded carbon or stainless steel rod (all-thread) that comply with the code reference standards and that have thread characteristics comparable with ANSI B1.1 UNC Coarse Thread Series or ANSI B1.13M M Profile Metric Thread Series. Values for threaded rod types and associated nuts supplied by Hilti are provided here.

<sup>2</sup> Standard Specification for Alloy-Steel and Stainless Steel Bolting Materials for High-Temperature Service

<sup>3</sup> Standard Specification for Carbon and Alloy Steel Externally Threaded Metric Fasteners

<sup>4</sup> Mechanical properties of fasteners made of carbon steel and alloy steel - Part 1: Bolts, screws and studs

<sup>5</sup> Standard Steel Specification for Stainless Steel Bolts, Hex Cap Screws, and Studs

<sup>6</sup> Mechanical properties of corrosion-resistant stainless steel fasteners - Part 1: Bolts, screws and studs

<sup>7</sup> Based on 2-in. (50 mm) gauge length except for A 193, which are based on a gauge length of 4d and ISO 898, which is based on 5d.

<sup>8</sup> Nuts of other grades and styles having specified proof load stresses greater than the specified grade and style are also suitable. Nuts must have specified proof load stresses equal to or greater than the minimum tensile strength of the specified threaded rod.

<sup>9</sup> Nuts for fractional rods.

TABLE 4—SPECIFICATIONS AND PHYSICAL PROPERTIES OF COMMON STEEL REINFORCING BARS

REINFORCING BAR SPECIFICATION 		Minimum specified ultimate strength, $f_{uta}$	Minimum specified yield strength, $f_{ya}$
ASTM A615 <sup>1</sup> Gr. 60	psi (MPa)	80,000 (550)	60,000 (414)
ASTM A615 <sup>1</sup> Gr. 40	psi (MPa)	60,000 (414)	40,000 (276)
ASTM A706 <sup>2</sup> Gr. 60	psi (MPa)	80,000 (550)	60,000 (414)
DIN 488 <sup>3</sup> BSt 500	MPa (psi)	550 (79,750)	500 (72,500)
CAN/CSA-G30.18 <sup>4</sup> Gr. 400	MPa (psi)	540 (78,300)	400 (58,000)

<sup>1</sup> Standard Specification for Deformed and Plain Carbon Steel Bars for Concrete Reinforcement

<sup>2</sup> Standard Specification for Low Alloy Steel Deformed and Plain Bars for Concrete Reinforcement

<sup>3</sup> Reinforcing steel; reinforcing steel bars; dimensions and masses

<sup>4</sup> Billet-Steel Bars for Concrete Reinforcement

TABLE 5—SPECIFICATIONS AND PHYSICAL PROPERTIES OF FRACTIONAL AND METRIC HIS-N AND HIS-RN INSERTS

HILTI HIS-N AND HIS-RN INSERTS 		Minimum specified ultimate strength, $f_{uta}$	Minimum specified yield strength, $f_{ya}$
Carbon Steel DIN EN 10277-3 11SMnPb30+c or DIN 1561 9SMnPb28K <sup>3</sup> / <sub>8</sub> -in. and M8 to M10	psi (MPa)	71,050 (490)	59,450 (410)
Carbon Steel DIN EN 10277-3 11SMnPb30+c or DIN 1561 9SMnPb28K <sup>1</sup> / <sub>2</sub> to <sup>3</sup> / <sub>4</sub> -in. and M12 to M20	psi (MPa)	66,700 (460)	54,375 (375)
Stainless Steel EN 10088-3 X5CrNiMo 17-12-2	psi (MPa)	101,500 (700)	50,750 (350)

TABLE 6—SPECIFICATIONS AND PHYSICAL PROPERTIES OF COMMON BOLTS, CAP SCREWS AND STUDS FOR USE WITH HIS-N AND HIS-RN INSERTS<sup>1,2</sup>

BOLT, CAP SCREW OR STUD SPECIFICATION 		Minimum specified ultimate strength $f_{uta}$	Minimum specified yield strength 0.2 percent offset $f_{ya}$	$f_{uta}/f_{ya}$	Elongation, min.	Reduction of Area, min.	Specification for nuts <sup>6</sup>
SAE J429 <sup>3</sup> Grade 5	psi (MPa)	120,000 (828)	92,000 (634)	1.30	14	35	SAE J995
ASTM A325 <sup>4</sup> <sup>1</sup> / <sub>2</sub> to 1-in.	psi (MPa)	120,000 (828)	92,000 (634)	1.30	14	35	A563 C, C3, D, DH, DH3 Heavy Hex
ASTM A193 <sup>5</sup> Grade B8M (AISI 316) for use with HIS-RN	psi (MPa)	110,000 (759)	95,000 (655)	1.16	15	45	ASTM F594 <sup>7</sup> Alloy Group 1, 2 or 3
ASTM A193 <sup>5</sup> Grade B8T (AISI 321) for use with HIS-RN	psi (MPa)	125,000 (862)	100,000 (690)	1.25	12	35	ASTM F594 <sup>7</sup> Alloy Group 1, 2 or 3

<sup>1</sup> Minimum Grade 5 bolts, cap screws or studs must be used with carbon steel HIS inserts.

<sup>2</sup> Only stainless steel bolts, cap screws or studs must be used with HIS-RN inserts.

<sup>3</sup> Mechanical and Material Requirements for Externally Threaded Fasteners

<sup>4</sup> Standard Specification for Structural Bolts, Steel, Heat Treated, 120/105 ksi Minimum Tensile Strength

<sup>5</sup> Standard Specification for Alloy-Steel and Stainless Steel Bolting Materials for High-Temperature Service

<sup>6</sup> Nuts must have specified minimum proof load stress equal to or greater than the specified minimum full-size tensile strength of the specified stud.

<sup>7</sup> Nuts for stainless steel studs must be of the same alloy group as the specified bolt, cap screw, or stud.



Fractional and Metric HIT-Z and HIT-Z-R Anchor Rod

Steel Strength

TABLE 7—STEEL DESIGN INFORMATION FOR FRACTIONAL AND METRIC HIT-Z AND HIT-Z-R ANCHOR RODS

DESIGN INFORMATION	Symbol	Units	Nominal Rod Dia. (in.) Fractional				Units	Nominal Rod Dia. (mm) Metric				
			<sup>3</sup> / <sub>8</sub>	<sup>1</sup> / <sub>2</sub>	<sup>5</sup> / <sub>8</sub>	<sup>3</sup> / <sub>4</sub>		10	12	16	20	
Rod O.D.	<i>d</i>	in. (mm)	0.375 (9.5)	0.5 (12.7)	0.625 (15.9)	0.75 (19.1)	mm (in.)	10 (0.39)	12 (0.47)	16 (0.63)	20 (0.79)	
Rod effective cross-sectional area	<i>A<sub>se</sub></i>	in. <sup>2</sup> (mm <sup>2</sup> )	0.0775 (50)	0.1419 (92)	0.2260 (146)	0.3340 (216)	mm <sup>2</sup> (in. <sup>2</sup> )	58.0 (0.090)	84.3 (0.131)	157.0 (0.243)	245.0 (0.380)	
CARBON STEEL	Nominal strength as governed by steel strength <sup>1</sup>	<i>N<sub>sa</sub></i>	lb (kN)	7,306 (32.5)	13,377 (59.5)	21,306 (94.8)	31,472 (140.0)	kN (lb)	37.7 (8,475)	54.8 (12,318)	95.8 (21,529)	145.8 (32,770)
		<i>V<sub>sa</sub></i>	lb (kN)	3,215 (14.3)	5,886 (26.2)	9,375 (41.7)	13,848 (61.6)	kN (lb)	16.6 (3,729)	24.1 (5,420)	42.2 (9,476)	64.2 (14,421)
	Reduction for seismic shear	<i>α<sub>v,seis</sub></i>	-	0.65				-	0.65			
	Strength reduction factor for tension <sup>2</sup>	<i>φ</i>	-	0.65				-	0.65			
	Strength reduction factor for shear <sup>2</sup>	<i>φ</i>	-	0.60				-	0.60			
STAINLESS STEEL	Nominal strength as governed by steel strength <sup>1</sup>	<i>N<sub>sa</sub></i>	lb (kN)	7,306 (32.5)	13,377 (59.5)	21,306 (94.8)	31,472 (140.0)	kN (lb)	37.7 (8,475)	54.8 (12,318)	95.8 (21,529)	145.8 (32,770)
		<i>V<sub>sa</sub></i>	lb (kN)	4,384 (19.5)	8,026 (35.7)	12,783 (56.9)	18,883 (84.0)	kN (lb)	22.6 (5,085)	32.9 (7,391)	57.5 (12,922)	87.5 (19,666)
	Reduction for seismic shear	<i>α<sub>v,seis</sub></i>	-	0.79	0.75	0.65		-	0.79	0.75	0.65	
	Strength reduction factor for tension <sup>2</sup>	<i>φ</i>	-	0.65				-	0.65			
	Strength reduction factor for shear <sup>2</sup>	<i>φ</i>	-	0.60				-	0.60			

For SI: 1 inch = 25.4 mm, 1 lbf = 4.448 N, 1 psi = 0.006897 MPa.  
 For pound-inch units: 1 mm = 0.03937 inches, 1 N = 0.2248 lbf, 1 MPa = 145.0 psi

<sup>1</sup> Steel properties are minimum values and maximum values will vary due to the cold forming of the rod.  
<sup>2</sup> For use with the load combinations of ACI 318-19 and ACI 318-14 5.3 or ACI 318-11 9.2, as set forth in ACI 318-19 17.5.3, ACI 318-14 17.3.3 or ACI 318-11 D.4.3.

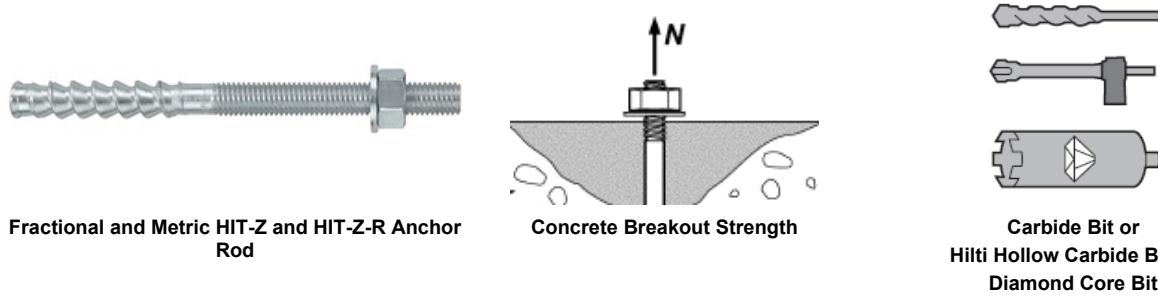

**TABLE 8—CONCRETE BREAKOUT DESIGN INFORMATION FOR U.S. CUSTOMARY UNIT HIT-Z AND HIT-Z-R ANCHOR ROD IN HOLES DRILLED WITH A HAMMER DRILL AND CARBIDE BIT (OR HILTI HOLLOW CARBIDE DRILL BIT) OR A CORE DRILL<sup>1</sup>**

DESIGN INFORMATION	Symbol	Units	Nominal Rod Dia. (in.) Fractional				Units	Nominal Rod Dia. (mm) Metric			
			3/8	1/2	5/8	3/4		10	12	16	20
Effectiveness factor for cracked concrete	$k_{c,cr}$	in-lb (SI)	17 (7.1)				SI (in-lb)	7.1 (17)			
Effectiveness factor for uncracked concrete	$k_{c,uncr}$	in-lb (SI)	24 (10)				SI (in-lb)	10 (24)			
Minimum embedment depth <sup>3</sup>	$h_{ef,min}$	in. (mm)	2 <sup>3</sup> / <sub>8</sub> (60)	2 <sup>3</sup> / <sub>4</sub> (70)	3 <sup>3</sup> / <sub>4</sub> (95)	4 (102)	mm (in.)	60 (2.4)	70 (2.8)	96 (3.8)	100 (3.9)
Maximum embedment depth <sup>3</sup>	$h_{ef,max}$	in. (mm)	4 <sup>1</sup> / <sub>2</sub> (114)	6 (152)	7 <sup>1</sup> / <sub>2</sub> (190)	8 <sup>1</sup> / <sub>2</sub> (216)	mm (in.)	120 (4.7)	144 (5.7)	192 (7.6)	220 (8.7)
Min. anchor spacing	$s_{min}$	-	See Section 4.1.9.1 of this report.				-	See Section 4.1.9.1 of this report.			
Min. edge distance	$c_{min}$	-	Pre-calculated combinations of anchor spacing and edge distance are given in Table 9 of this report.				-	Pre-calculated combinations of anchor spacing and edge distance are given in Table 9 of this report.			
Minimum concrete thickness Hole condition 1 <sup>3</sup>	$h_{min,1}$	in. (mm)	$h_{ef} + 2\frac{1}{4}$ ( $h_{ef} + 57$ )		$h_{ef} + 4$ ( $h_{ef} + 102$ )		mm (in.)	$h_{ef} + 60$ ( $h_{ef} + 2.4$ )		$h_{ef} + 100$ ( $h_{ef} + 3.9$ )	
Minimum concrete thickness Hole condition 2 <sup>3</sup>	$h_{min,2}$	in. (mm)	$h_{ef} + 1\frac{1}{4} \geq 4$ ( $h_{ef} + 32 \geq 100$ )		$h_{ef} + 1\frac{3}{4}$ ( $h_{ef} + 45$ )		mm (in.)	$h_{ef} + 30 \geq 100$ ( $h_{ef} + 1.25 \geq 3.9$ )		$h_{ef} + 45$ ( $h_{ef} + 1.8$ )	
Critical edge distance – splitting (for uncracked concrete)	$c_{ac}$	-	See Section 4.1.10.1 of this report				-	See Section 4.1.10.1 of this report			
Strength reduction factor for tension, concrete failure modes, Condition B (supplemental reinforcement not present) <sup>2</sup>	$\phi$	-	0.65				-	0.65			
Strength reduction factor for shear, concrete failure modes, Condition B (supplemental reinforcement not present) <sup>2</sup>	$\phi$	-	0.70				-	0.70			

For SI: 1 inch  $\equiv$  25.4 mm, 1 lbf = 4.448 N, 1 psi = 0.006897 MPa.  
For pound-inch units: 1 mm = 0.03937 inches, 1 N = 0.2248 lbf, 1 MPa = 145.0 psi

<sup>1</sup> Additional setting information is described in Figure 6, Manufacturers Printed Installation Instructions (MPII).

<sup>2</sup> The strength reduction factor applies when the load combinations from the IBC or ACI 318 are used and the requirements of ACI 318-19 17.5.3, ACI 318-14 17.3.3 or ACI 318-11 D.4.3, as applicable, are met. If the load combinations of ACI 318-11 Appendix C are used, the appropriate strength reduction factor must be determined in accordance with ACI 318-11 D.4.4.<sup>3</sup> Borehole condition is described in Figure 4 below.

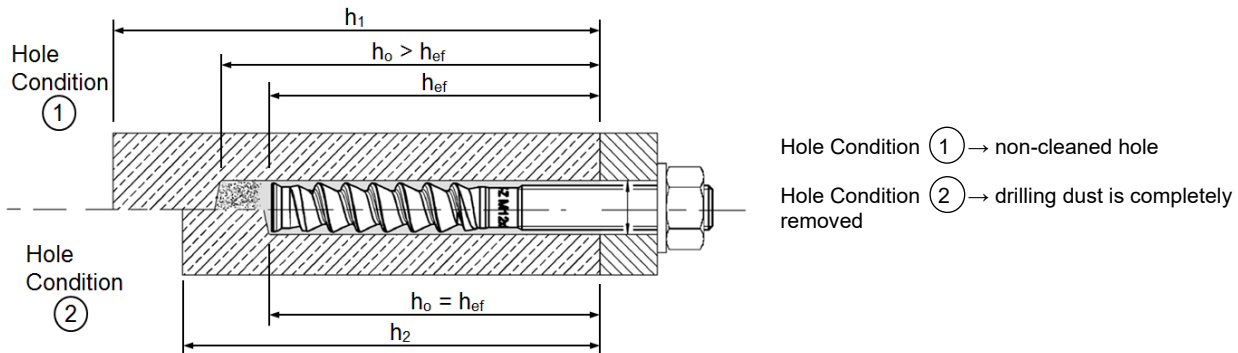

**FIGURE 4—BOREHOLE SETTING CONDITIONS FOR HILTI HIT-Z AND HIT-Z-R ANCHOR RODS**

**TABLE 9—PRE-CALCULATED EDGE DISTANCE AND SPACING COMBINATIONS FOR HILTI HIT-Z AND HIT-Z-R RODS**

DESIGN INFORMATION			Symbol	Units	Nominal Rod Diameter (in.) – Fractional								
Rod O.D.			<i>d</i>	in. (mm)	3/8 (9.5)								
Effective embedment			<i>h<sub>ef</sub></i>	in. (mm)	2 3/8 (60)		3 3/8 (86)		4 1/2 (114)				
Drilled hole condition <sup>1</sup>			-	-	2	1 or 2		2	1 or 2				
Minimum concrete thickness			<i>h</i>	in. (mm)	4 (102)	4 5/8 (117)	5 3/4 (146)	4 5/8 (117)	5 5/8 (143)	6 3/8 (162)	5 3/4 (146)	6 3/4 (171)	7 3/8 (187)
UNCRACKED CONCRETE	Minimum edge and spacing Case 1 <sup>2</sup>	<i>c<sub>min,1</sub></i>	in. (mm)	3 1/8 (79)	2 3/4 (70)	2 1/4 (57)	2 3/4 (70)	2 1/4 (57)	2 (51)	2 1/4 (57)	1 7/8 (48)	1 7/8 (48)	
		<i>s<sub>min,1</sub></i>	in. (mm)	9 1/8 (232)	7 3/4 (197)	6 1/8 (156)	7 3/4 (197)	6 1/2 (165)	5 5/8 (143)	6 1/8 (156)	5 3/8 (137)	4 1/2 (114)	
	Minimum edge and spacing Case 2 <sup>2</sup>	<i>c<sub>min,2</sub></i>	in. (mm)	5 5/8 (143)	4 3/4 (121)	3 3/4 (95)	4 3/4 (121)	3 7/8 (98)	3 1/4 (83)	3 3/4 (95)	3 1/8 (79)	2 3/4 (70)	
		<i>s<sub>min,2</sub></i>	in. (mm)	1 7/8 (48)	1 7/8 (48)	1 7/8 (48)	1 7/8 (48)	1 7/8 (48)	1 7/8 (48)	1 7/8 (48)	1 7/8 (48)	1 7/8 (48)	1 7/8 (48)
CRACKED CONCRETE	Minimum edge and spacing Case 1 <sup>2</sup>	<i>c<sub>min,1</sub></i>	in. (mm)	2 1/8 (54)	1 7/8 (48)	1 7/8 (48)	1 7/8 (48)	1 7/8 (48)	1 7/8 (48)	1 7/8 (48)	1 7/8 (48)	1 7/8 (48)	
		<i>s<sub>min,1</sub></i>	in. (mm)	6 3/8 (162)	5 1/2 (140)	4 1/4 (108)	5 1/2 (140)	3 1/2 (89)	2 5/8 (67)	3 1/4 (83)	2 (51)	1 7/8 (48)	
	Minimum edge and spacing Case 2 <sup>2</sup>	<i>c<sub>min,2</sub></i>	in. (mm)	3 5/8 (92)	3 1/8 (79)	2 3/8 (60)	3 1/8 (79)	2 1/2 (64)	2 1/8 (54)	2 3/8 (60)	2 (51)	1 7/8 (48)	
		<i>s<sub>min,2</sub></i>	in. (mm)	1 7/8 (48)	1 7/8 (48)	1 7/8 (48)	1 7/8 (48)	1 7/8 (48)	1 7/8 (48)	1 7/8 (48)	1 7/8 (48)	1 7/8 (48)	

DESIGN INFORMATION			Symbol	Units	Nominal Rod Diameter (in.) – Fractional								
Rod O.D.			<i>d</i>	in. (mm)	1/2 (12.7)								
Effective embedment			<i>h<sub>ef</sub></i>	in. (mm)	2-3/4 (70)		4 1/2 (114)		6 (152)				
Drilled hole condition <sup>1</sup>			-	-	2	1 or 2		2	1 or 2				
Minimum concrete thickness			<i>h</i>	in. (mm)	4 (102)	5 (127)	7 1/8 (181)	5 3/4 (146)	6 3/4 (171)	8 1/4 (210)	7 1/4 (184)	8 1/4 (210)	9 3/4 (248)
UNCRACKED CONCRETE	Minimum edge and spacing Case 1 <sup>2</sup>	<i>c<sub>min,1</sub></i>	in. (mm)	5 1/8 (130)	4 7/8 (105)	2 7/8 (73)	3 5/8 (92)	3 (76)	2 1/2 (64)	2 1/8 (73)	2 1/2 (64)	2 1/2 (64)	
		<i>s<sub>min,1</sub></i>	in. (mm)	14 7/8 (378)	11 7/8 (302)	8 5/8 (219)	10 1/4 (260)	9 (229)	7 1/4 (184)	8 1/8 (206)	7 1/4 (184)	5 (127)	
	Minimum edge and spacing Case 2 <sup>2</sup>	<i>c<sub>min,2</sub></i>	in. (mm)	9 1/4 (235)	7 1/4 (184)	4 7/8 (124)	6 1/4 (159)	5 1/4 (133)	4 7/8 (105)	4 1/4 (121)	4 1/8 (105)	3 3/8 (86)	
		<i>s<sub>min,2</sub></i>	in. (mm)	2 1/2 (64)	2 1/2 (64)	2 1/2 (64)	2 1/2 (64)	2 1/2 (64)	2 1/2 (64)	2 1/2 (64)	2 1/2 (64)	2 1/2 (64)	
CRACKED CONCRETE	Minimum edge and spacing Case 1 <sup>2</sup>	<i>c<sub>min,1</sub></i>	in. (mm)	3 5/8 (92)	3 (76)	2 1/2 (64)	2 5/8 (67)	2 1/2 (64)	2 1/2 (64)	2 1/2 (64)	2 1/2 (64)	2 1/2 (64)	
		<i>s<sub>min,1</sub></i>	in. (mm)	10 7/8 (276)	8 1/2 (216)	6 (152)	7 3/8 (187)	5 1/2 (140)	3 1/8 (79)	4 1/2 (114)	3 1/8 (79)	2 1/2 (64)	
	Minimum edge and spacing Case 2 <sup>2</sup>	<i>c<sub>min,2</sub></i>	in. (mm)	6 1/2 (165)	5 (127)	3 1/4 (83)	4 1/4 (108)	3 1/2 (89)	2 3/4 (70)	3 1/4 (83)	2 3/4 (70)	2 1/2 (64)	
		<i>s<sub>min,2</sub></i>	in. (mm)	2 1/2 (64)	2 1/2 (64)	2 1/2 (64)	2 1/2 (64)	2 1/2 (64)	2 1/2 (64)	2 1/2 (64)	2 1/2 (64)	2 1/2 (64)	

DESIGN INFORMATION			Symbol	Units	Nominal Rod Diameter (in.) – Fractional								
Rod O.D.			<i>d</i>	in. (mm)	5/8 (15.9)								
Effective embedment			<i>h<sub>ef</sub></i>	in. (mm)	3 3/4 (95)		5 5/8 (143)		7 1/2 (191)				
Drilled hole condition <sup>1</sup>			-	-	2	1 or 2		2	1 or 2				
Minimum concrete thickness			<i>h</i>	in. (mm)	5 1/2 (140)	7 3/4 (197)	9 3/8 (238)	7 3/8 (187)	9 5/8 (244)	10 1/2 (267)	9 1/4 (235)	11 1/2 (292)	12 1/4 (311)
UNCRACKED CONCRETE	Minimum edge and spacing Case 1 <sup>2</sup>	<i>c<sub>min,1</sub></i>	in. (mm)	6 1/4 (159)	4 1/2 (114)	3 3/4 (95)	4 5/8 (117)	3 5/8 (92)	3 1/4 (83)	3 3/4 (95)	3 1/8 (79)	3 1/8 (79)	
		<i>s<sub>min,1</sub></i>	in. (mm)	18 3/8 (467)	12 7/8 (327)	10 5/8 (270)	13 7/8 (352)	10 3/8 (264)	9 3/4 (248)	10 7/8 (276)	8 3/8 (213)	7 3/8 (187)	
	Minimum edge and spacing Case 2 <sup>2</sup>	<i>c<sub>min,2</sub></i>	in. (mm)	11 3/8 (289)	7 3/4 (197)	6 1/4 (159)	8 1/4 (210)	6 1/8 (156)	5 1/2 (140)	6 1/8 (162)	4 7/8 (124)	4 5/8 (117)	
		<i>s<sub>min,2</sub></i>	in. (mm)	3 1/8 (79)	3 1/8 (79)	3 1/8 (79)	3 1/8 (79)	3 1/8 (79)	3 1/8 (79)	3 1/8 (79)	3 1/8 (79)	3 1/8 (79)	
CRACKED CONCRETE	Minimum edge and spacing Case 1 <sup>2</sup>	<i>c<sub>min,1</sub></i>	in. (mm)	4 5/8 (117)	3 3/8 (86)	3 1/8 (79)	3 1/2 (89)	3 1/8 (79)	3 1/8 (79)	3 1/8 (79)	3 1/8 (79)	3 1/8 (79)	
		<i>s<sub>min,1</sub></i>	in. (mm)	13 7/8 (352)	9 1/2 (241)	8 3/4 (222)	10 1/8 (257)	6 1/2 (165)	5 3/8 (137)	7 1/8 (181)	3 1/8 (98)	3 1/8 (79)	
	Minimum edge and spacing Case 2 <sup>2</sup>	<i>c<sub>min,2</sub></i>	in. (mm)	8 1/4 (210)	5 1/2 (140)	4 3/8 (111)	5 7/8 (149)	4 1/4 (108)	3 7/8 (98)	4 1/2 (114)	3 3/8 (86)	3 1/8 (79)	
		<i>s<sub>min,2</sub></i>	in. (mm)	3 1/8 (79)	3 1/8 (79)	3 1/8 (79)	3 1/8 (79)	3 1/8 (79)	3 1/8 (79)	3 1/8 (79)	3 1/8 (79)	3 1/8 (79)	

For **SI**: 1 inch ≅ 25.4 mm

<sup>1</sup> See Figure 4 for description of drilled hole condition.

<sup>2</sup> Linear interpolation is permitted to establish an edge distance and spacing combination between case 1 and case 2.

Linear interpolation for a specific edge distance *c*, where *c<sub>min,1</sub>* < *c* < *c<sub>min,2</sub>*, will determine the permissible spacing, *s*, as follows:

$$s \geq s_{min,2} + \left( \frac{s_{min,1} - s_{min,2}}{c_{min,1} - c_{min,2}} \right) (c - c_{min,2})$$



**TABLE 9—PRE-CALCULATED EDGE DISTANCE AND SPACING COMBINATIONS FOR HILTI HIT-Z AND HIT-Z-R RODS (Continued)**

DESIGN INFORMATION			Symbol	Units	Nominal Rod Diameter (in.) – Fractional								
Rod O.D.			<i>d</i>	in. (mm)	<sup>3</sup> / <sub>4</sub> (19.1)								
Effective embedment			<i>h<sub>ef</sub></i>	in. (mm)	4 (102)			6 <sup>3</sup> / <sub>4</sub> (171)		8 <sup>1</sup> / <sub>2</sub> (216)			
Drilled hole condition <sup>1</sup>			-	-	2	1 or 2		2	1 or 2		2	1 or 2	
Minimum concrete thickness			<i>h</i>	in. (mm)	5 <sup>3</sup> / <sub>4</sub> (146)	8 (203)	11 <sup>1</sup> / <sub>2</sub> (292)	8 <sup>1</sup> / <sub>2</sub> (216)	10 <sup>3</sup> / <sub>4</sub> (273)	13 <sup>1</sup> / <sub>8</sub> (333)	10 <sup>1</sup> / <sub>4</sub> (260)	12 <sup>1</sup> / <sub>2</sub> (318)	14 <sup>1</sup> / <sub>2</sub> (368)
UNCRACKED CONCRETE	Minimum edge and spacing Case 1 <sup>2</sup>	<i>c<sub>min,1</sub></i>	in. (mm)	9 <sup>3</sup> / <sub>4</sub> (248)	7 (178)	5 (127)	6 <sup>5</sup> / <sub>8</sub> (168)	5 <sup>1</sup> / <sub>4</sub> (133)	4 <sup>1</sup> / <sub>4</sub> (108)	5 <sup>1</sup> / <sub>2</sub> (140)	4 <sup>1</sup> / <sub>2</sub> (114)	4 (102)	
		<i>s<sub>min,1</sub></i>	in. (mm)	28 <sup>3</sup> / <sub>4</sub> (730)	20 <sup>5</sup> / <sub>8</sub> (524)	14 (356)	19 <sup>3</sup> / <sub>8</sub> (492)	15 <sup>1</sup> / <sub>4</sub> (387)	12 <sup>5</sup> / <sub>8</sub> (321)	16 (406)	13 <sup>1</sup> / <sub>4</sub> (337)	11 (279)	
	Minimum edge and spacing Case 2 <sup>2</sup>	<i>c<sub>min,2</sub></i>	in. (mm)	18 <sup>1</sup> / <sub>8</sub> (460)	12 <sup>5</sup> / <sub>8</sub> (321)	8 <sup>1</sup> / <sub>2</sub> (216)	11 <sup>1</sup> / <sub>8</sub> (302)	9 <sup>1</sup> / <sub>8</sub> (232)	7 <sup>1</sup> / <sub>4</sub> (184)	9 <sup>1</sup> / <sub>8</sub> (244)	7 <sup>3</sup> / <sub>4</sub> (197)	6 <sup>1</sup> / <sub>2</sub> (165)	
		<i>s<sub>min,2</sub></i>	in. (mm)	3 <sup>3</sup> / <sub>4</sub> (95)	3 <sup>3</sup> / <sub>4</sub> (95)	3 <sup>3</sup> / <sub>4</sub> (95)	3 <sup>3</sup> / <sub>4</sub> (95)	3 <sup>3</sup> / <sub>4</sub> (95)	3 <sup>3</sup> / <sub>4</sub> (95)	3 <sup>3</sup> / <sub>4</sub> (95)	3 <sup>3</sup> / <sub>4</sub> (95)	3 <sup>3</sup> / <sub>4</sub> (95)	3 <sup>3</sup> / <sub>4</sub> (95)
CRACKED CONCRETE	Minimum edge and spacing Case 1 <sup>2</sup>	<i>c<sub>min,1</sub></i>	in. (mm)	7 <sup>1</sup> / <sub>4</sub> (184)	5 <sup>1</sup> / <sub>4</sub> (133)	4 <sup>1</sup> / <sub>8</sub> (105)	5 (127)	4 (102)	3 <sup>3</sup> / <sub>4</sub> (95)	4 <sup>1</sup> / <sub>8</sub> (105)	3 <sup>3</sup> / <sub>4</sub> (95)	3 <sup>3</sup> / <sub>4</sub> (95)	
		<i>s<sub>min,1</sub></i>	in. (mm)	21 <sup>3</sup> / <sub>4</sub> (552)	15 <sup>1</sup> / <sub>2</sub> (394)	12 <sup>1</sup> / <sub>4</sub> (311)	14 <sup>1</sup> / <sub>2</sub> (368)	11 <sup>3</sup> / <sub>8</sub> (289)	9 (229)	12 <sup>1</sup> / <sub>8</sub> (308)	8 <sup>3</sup> / <sub>4</sub> (222)	6 <sup>1</sup> / <sub>2</sub> (165)	
	Minimum edge and spacing Case 2 <sup>2</sup>	<i>c<sub>min,2</sub></i>	in. (mm)	13 <sup>1</sup> / <sub>4</sub> (337)	9 <sup>1</sup> / <sub>4</sub> (235)	6 (152)	8 <sup>5</sup> / <sub>8</sub> (219)	6 <sup>5</sup> / <sub>8</sub> (168)	5 <sup>1</sup> / <sub>8</sub> (130)	7 (178)	5 <sup>1</sup> / <sub>2</sub> (140)	4 <sup>1</sup> / <sub>2</sub> (114)	
		<i>s<sub>min,2</sub></i>	in. (mm)	3 <sup>3</sup> / <sub>4</sub> (95)	3 <sup>3</sup> / <sub>4</sub> (95)	3 <sup>3</sup> / <sub>4</sub> (95)	3 <sup>3</sup> / <sub>4</sub> (95)	3 <sup>3</sup> / <sub>4</sub> (95)	3 <sup>3</sup> / <sub>4</sub> (95)	3 <sup>3</sup> / <sub>4</sub> (95)	3 <sup>3</sup> / <sub>4</sub> (95)	3 <sup>3</sup> / <sub>4</sub> (95)	

DESIGN INFORMATION			Symbol	Units	Nominal Rod Diameter (mm) – Metric								
Rod O.D.			<i>d</i>	mm (in.)	10 (0.39)								
Effective embedment			<i>h<sub>ef</sub></i>	mm (in.)	60 (2.36)			90 (3.54)		120 (4.72)			
Drilled hole condition <sup>1</sup>			-	-	2	1 or 2		2	1 or 2		2	1 or 2	
Minimum concrete thickness			<i>h</i>	mm (in.)	100 (3.94)	120 (4.72)	156 (6.14)	120 (4.72)	150 (5.91)	176 (6.91)	150 (5.91)	180 (7.09)	197 (7.74)
UNCRACKED CONCRETE	Minimum edge and spacing Case 1 <sup>2</sup>	<i>c<sub>min,1</sub></i>	mm (in.)	99 (3.90)	83 (3.27)	64 (2.52)	83 (3.27)	66 (2.60)	57 (2.24)	66 (2.60)	55 (2.17)	51 (2.01)	
		<i>s<sub>min,1</sub></i>	mm (in.)	295 (11.61)	244 (9.61)	187 (7.36)	244 (9.61)	197 (7.76)	166 (6.54)	197 (7.76)	164 (6.46)	148 (5.83)	
	Minimum edge and spacing Case 2 <sup>2</sup>	<i>c<sub>min,2</sub></i>	mm (in.)	181 (7.13)	148 (5.83)	110 (4.33)	148 (5.83)	115 (4.53)	96 (3.78)	115 (4.53)	93 (3.66)	84 (3.31)	
		<i>s<sub>min,2</sub></i>	mm (in.)	50 (1.97)	50 (1.97)	50 (1.97)	50 (1.97)	50 (1.97)	50 (1.97)	50 (1.97)	50 (1.97)	50 (1.97)	
CRACKED CONCRETE	Minimum edge and spacing Case 1 <sup>2</sup>	<i>c<sub>min,1</sub></i>	mm (in.)	71 (2.80)	59 (2.32)	52 (2.05)	59 (2.32)	50 (1.97)	50 (1.97)	50 (1.97)	50 (1.97)	50 (1.97)	
		<i>s<sub>min,1</sub></i>	mm (in.)	209 (8.23)	174 (6.85)	150 (5.91)	174 (6.85)	131 (5.16)	106 (4.17)	131 (5.16)	84 (3.31)	66 (2.60)	
	Minimum edge and spacing Case 2 <sup>2</sup>	<i>c<sub>min,2</sub></i>	mm (in.)	124 (4.88)	101 (3.98)	74 (2.91)	101 (3.98)	77 (3.03)	64 (2.52)	77 (3.03)	62 (2.44)	55 (2.17)	
		<i>s<sub>min,2</sub></i>	mm (in.)	50 (1.97)	50 (1.97)	50 (1.97)	50 (1.97)	50 (1.97)	50 (1.97)	50 (1.97)	50 (1.97)	50 (1.97)	

DESIGN INFORMATION			Symbol	Units	Nominal Rod Diameter (mm) – Metric								
Rod O.D.			<i>d</i>	mm (in.)	12 (0.47)								
Effective embedment			<i>h<sub>ef</sub></i>	mm (in.)	70 (2.76)			108 (4.25)		144 (5.67)			
Drilled hole condition <sup>1</sup>			-	-	2	1 or 2		2	1 or 2		2	1 or 2	
Minimum concrete thickness			<i>h</i>	mm (in.)	100 (3.94)	130 (5.12)	184 (7.24)	138 (5.43)	168 (6.61)	209 (8.21)	174 (6.85)	204 (8.03)	234 (9.21)
UNCRACKED CONCRETE	Minimum edge and spacing Case 1 <sup>2</sup>	<i>c<sub>min,1</sub></i>	mm (in.)	139 (5.47)	107 (4.21)	76 (2.99)	101 (3.98)	83 (3.27)	67 (2.64)	80 (3.15)	68 (2.68)	60 (2.36)	
		<i>s<sub>min,1</sub></i>	mm (in.)	416 (16.38)	320 (12.60)	225 (8.86)	300 (11.81)	247 (9.72)	199 (7.83)	239 (9.41)	204 (8.03)	176 (6.93)	
	Minimum edge and spacing Case 2 <sup>2</sup>	<i>c<sub>min,2</sub></i>	mm (in.)	258 (10.16)	194 (7.64)	131 (5.16)	181 (7.13)	146 (5.75)	114 (4.49)	140 (5.51)	116 (4.57)	99 (3.90)	
		<i>s<sub>min,2</sub></i>	mm (in.)	60 (2.36)	60 (2.36)	60 (2.36)	60 (2.36)	60 (2.36)	60 (2.36)	60 (2.36)	60 (2.36)	60 (2.36)	
CRACKED CONCRETE	Minimum edge and spacing Case 1 <sup>2</sup>	<i>c<sub>min,1</sub></i>	mm (in.)	101 (3.98)	78 (3.07)	62 (2.44)	74 (2.91)	61 (2.40)	60 (2.36)	60 (2.36)	60 (2.36)	60 (2.36)	
		<i>s<sub>min,1</sub></i>	mm (in.)	303 (11.93)	232 (9.13)	186 (7.32)	217 (8.54)	178 (7.01)	126 (4.96)	168 (6.61)	117 (4.61)	79 (3.11)	
	Minimum edge and spacing Case 2 <sup>2</sup>	<i>c<sub>min,2</sub></i>	mm (in.)	182 (7.17)	136 (5.35)	90 (3.54)	127 (5.00)	101 (3.98)	77 (3.03)	96 (3.78)	79 (3.11)	67 (2.64)	
		<i>s<sub>min,2</sub></i>	mm (in.)	60 (2.36)	60 (2.36)	60 (2.36)	60 (2.36)	60 (2.36)	60 (2.36)	60 (2.36)	60 (2.36)	60 (2.36)	

For **SI**: 1 inch ≡ 25.4 mm

<sup>1</sup> See Figure 4 for description of drilled hole condition.

<sup>2</sup> Linear interpolation is permitted to establish an edge distance and spacing combination between case 1 and case 2.

Linear interpolation for a specific edge distance *c*, where *c<sub>min,1</sub>* < *c* < *c<sub>min,2</sub>*, will determine the permissible spacing, *s*, as follows:

$$s \geq s_{min,2} + \left( \frac{s_{min,1} - s_{min,2}}{c_{min,1} - c_{min,2}} \right) (c - c_{min,2})$$

**TABLE 9—PRE-CALCULATED EDGE DISTANCE AND SPACING COMBINATIONS FOR HILTI HIT-Z AND HIT-Z-R RODS (Continued)**

DESIGN INFORMATION			Symbol	Units	Nominal Rod Diameter (mm) – Metric								
Rod O.D.			<i>d</i>	mm (in.)	16 (0.63)								
Effective embedment			<i>h<sub>ef</sub></i>	mm (in.)	96 (3.78)			144 (5.67)		192 (7.56)			
Drilled hole condition <sup>1</sup>			-	-	2	1 or 2		2	1 or 2		2	1 or 2	
Minimum concrete thickness			<i>h</i>	mm (in.)	141 (5.55)	196 (7.72)	237 (9.33)	189 (7.44)	244 (9.61)	269 (10.57)	237 (9.33)	292 (11.50)	312 (12.28)
UNCRACKED CONCRETE	Minimum edge and spacing Case 1 <sup>2</sup>	<i>c<sub>min,1</sub></i>	mm (in.)	158 (6.22)	114 (4.49)	94 (3.70)	118 (4.65)	92 (3.62)	83 (3.27)	94 (3.70)	80 (3.15)	80 (3.15)	
		<i>s<sub>min,1</sub></i>	mm (in.)	473 (18.62)	339 (13.35)	281 (11.06)	352 (13.86)	271 (10.67)	248 (9.76)	281 (11.06)	217 (8.54)	188 (7.40)	
	Minimum edge and spacing Case 2 <sup>2</sup>	<i>c<sub>min,2</sub></i>	mm (in.)	289 (11.38)	201 (7.91)	161 (6.34)	209 (8.23)	156 (6.14)	139 (5.47)	161 (6.34)	126 (4.96)	116 (4.57)	
		<i>s<sub>min,2</sub></i>	mm (in.)	80 (3.15)	80 (3.15)	80 (3.15)	80 (3.15)	80 (3.15)	80 (3.15)	80 (3.15)	80 (3.15)	80 (3.15)	80 (3.15)
CRACKED CONCRETE	Minimum edge and spacing Case 1 <sup>2</sup>	<i>c<sub>min,1</sub></i>	mm (in.)	116 (4.57)	83 (3.27)	80 (3.15)	86 (3.39)	80 (3.15)	80 (3.15)	80 (3.15)	80 (3.15)	80 (3.15)	
		<i>s<sub>min,1</sub></i>	mm (in.)	343 (13.50)	248 (9.76)	211 (8.31)	258 (10.16)	160 (6.30)	129 (5.08)	171 (6.73)	94 (3.70)	81 (3.19)	
	Minimum edge and spacing Case 2 <sup>2</sup>	<i>c<sub>min,2</sub></i>	mm (in.)	204 (8.03)	139 (5.47)	111 (4.37)	146 (5.75)	107 (4.21)	95 (3.74)	111 (4.37)	85 (3.35)	80 (3.15)	
		<i>s<sub>min,2</sub></i>	mm (in.)	80 (3.15)	80 (3.15)	80 (3.15)	80 (3.15)	80 (3.15)	80 (3.15)	80 (3.15)	80 (3.15)	80 (3.15)	80 (3.15)

DESIGN INFORMATION			Symbol	Units	Nominal Rod Diameter (mm) – Metric								
Rod O.D.			<i>d</i>	mm (in.)	20 (0.79)								
Effective embedment			<i>h<sub>ef</sub></i>	mm (in.)	100 (3.94)			180 (7.09)		220 (8.66)			
Drilled hole condition <sup>1</sup>			-	-	2	1 or 2		2	1 or 2		2	1 or 2	
Minimum concrete thickness			<i>h</i>	mm (in.)	145 (5.71)	200 (7.87)	282 (11.08)	225 (8.86)	280 (11.02)	335 (13.17)	265 (10.43)	320 (12.60)	370 (14.57)
UNCRACKED CONCRETE	Minimum edge and spacing Case 1 <sup>2</sup>	<i>c<sub>min,1</sub></i>	mm (in.)	235 (9.25)	170 (6.69)	121 (4.76)	152 (5.98)	122 (4.80)	103 (4.06)	129 (5.08)	107 (4.21)	100 (3.94)	
		<i>s<sub>min,1</sub></i>	mm (in.)	702 (27.64)	511 (20.12)	362 (14.25)	451 (17.76)	363 (14.29)	301 (11.85)	383 (15.08)	317 (12.48)	252 (9.92)	
	Minimum edge and spacing Case 2 <sup>2</sup>	<i>c<sub>min,2</sub></i>	mm (in.)	436 (17.17)	307 (12.09)	209 (8.23)	269 (10.59)	210 (8.27)	170 (6.69)	224 (8.82)	180 (7.09)	151 (5.94)	
		<i>s<sub>min,2</sub></i>	mm (in.)	100 (3.94)	100 (3.94)	100 (3.94)	100 (3.94)	100 (3.94)	100 (3.94)	100 (3.94)	100 (3.94)	100 (3.94)	100 (3.94)
CRACKED CONCRETE	Minimum edge and spacing Case 1 <sup>2</sup>	<i>c<sub>min,1</sub></i>	mm (in.)	176 (6.93)	128 (5.04)	102 (4.02)	114 (4.49)	100 (3.94)	100 (3.94)	100 (3.94)	100 (3.94)	100 (3.94)	
		<i>s<sub>min,1</sub></i>	mm (in.)	526 (20.71)	380 (14.96)	298 (11.73)	337 (13.27)	246 (9.69)	163 (6.42)	277 (10.91)	178 (7.01)	113 (4.45)	
	Minimum edge and spacing Case 2 <sup>2</sup>	<i>c<sub>min,2</sub></i>	mm (in.)	318 (12.52)	222 (8.74)	148 (5.83)	193 (7.60)	149 (5.87)	119 (4.69)	159 (6.26)	126 (4.96)	105 (4.13)	
		<i>s<sub>min,2</sub></i>	mm (in.)	100 (3.94)	100 (3.94)	100 (3.94)	100 (3.94)	100 (3.94)	100 (3.94)	100 (3.94)	100 (3.94)	100 (3.94)	100 (3.94)

For **SI**: 1 inch ≅ 25.4 mm

<sup>1</sup> See Figure 4 for description of drilled hole condition.

<sup>2</sup> Linear interpolation is permitted to establish an edge distance and spacing combination between case 1 and case 2.

Linear interpolation for a specific edge distance *c*, where *c<sub>min,1</sub>* < *c* < *c<sub>min,2</sub>*, will determine the permissible spacing, *s*, as follows:

$$s \geq s_{min,2} + \frac{(s_{min,1} - s_{min,2})}{(c_{min,1} - c_{min,2})} (c - c_{min,2})$$

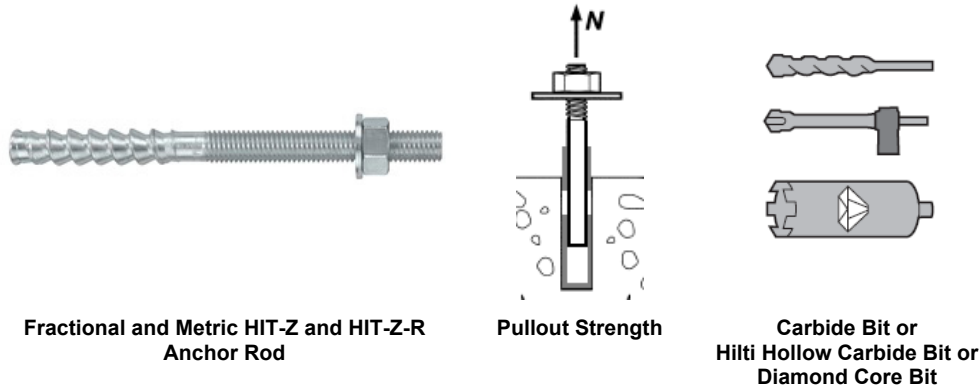

**TABLE 10—PULLOUT STRENGTH DESIGN INFORMATION FOR FRACTIONAL AND METRIC HILTI HIT-Z AND HIT-Z-R RODS IN HOLES DRILLED WITH A HAMMER DRILL AND CARBIDE BIT (OR HILTI HOLLOW CARBIDE DRILL BIT) OR A CORE DRILL<sup>1</sup>**

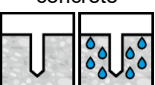
DESIGN INFORMATION		Symbol	Units	Nominal Rod Dia. (in.) Fractional				Units	Nominal Rod Dia. (mm) Metric			
				<sup>3</sup> / <sub>8</sub>	<sup>1</sup> / <sub>2</sub>	<sup>5</sup> / <sub>8</sub>	<sup>3</sup> / <sub>4</sub>		10	12	16	20
Minimum embedment depth		$h_{ef,min}$	in. (mm)	2 <sup>3</sup> / <sub>8</sub> (60)	2 <sup>3</sup> / <sub>4</sub> (70)	3 <sup>3</sup> / <sub>4</sub> (95)	4 (102)	mm (in.)	60 (2.4)	70 (2.8)	96 (3.8)	100 (3.9)
Maximum embedment depth		$h_{ef,max}$	in. (mm)	4 <sup>1</sup> / <sub>2</sub> (114)	6 (152)	7 <sup>1</sup> / <sub>2</sub> (190)	8 <sup>1</sup> / <sub>2</sub> (216)	mm (in.)	120 (4.7)	144 (5.7)	192 (7.6)	220 (8.7)
Temperature range A <sup>2</sup>	Pullout strength in cracked concrete	$N_{p,cr}$	lb (kN)	7,952 (35.4)	10,936 (48.6)	21,391 (95.1)	27,930 (124.2)	kN (lb)	39.1 (8,790)	43.8 (9,847)	98.0 (22,032)	127.9 (28,754)
	Pullout strength in uncracked concrete	$N_{p,uncr}$	lb (kN)	7,952 (35.4)	11,719 (52.1)	21,391 (95.1)	28,460 (126.6)	kN (lb)	39.1 (8,790)	46.9 (10,545)	98.0 (22,028)	130.3 (29,293)
Temperature range B <sup>2</sup>	Pullout strength in cracked concrete	$N_{p,cr}$	lb (kN)	7,952 (35.4)	10,936 (48.6)	21,391 (95.1)	27,930 (124.2)	kN (lb)	39.1 (8,790)	43.8 (9,847)	98.0 (22,032)	127.9 (28,754)
	Pullout strength in uncracked concrete	$N_{p,uncr}$	lb (kN)	7,952 (35.4)	11,719 (52.1)	21,391 (95.1)	28,460 (126.6)	kN (lb)	39.1 (8,790)	46.9 (10,545)	98.0 (22,028)	130.3 (29,293)
Temperature range C <sup>2</sup>	Pullout strength in cracked concrete	$N_{p,cr}$	lb (kN)	7,182 (31.9)	9,877 (43.9)	19,321 (85.9)	25,227 (112.2)	kN (lb)	35.3 (7,936)	39.5 (8,880)	88.5 (19,897)	115.5 (25,967)
	Pullout strength in uncracked concrete	$N_{p,uncr}$	lb (kN)	7,182 (31.9)	10,585 (47.1)	19,321 (85.9)	25,705 (114.3)	kN (lb)	35.3 (7,936)	42.4 (9,532)	88.5 (19,897)	117.7 (26,461)
Permissible installation conditions	Dry concrete, water saturated concrete	Anchor Category	-	1				-	1			
		$\phi_d, \phi_{ws}$	-	0.65				-	0.65			
Reduction for seismic tension		$\alpha_{N,seis}$	-	0.94	1.0			-	1.0	0.89	1.0	

For SI: 1 inch ≡ 25.4 mm, 1 lbf = 4.448 N, 1 psi = 0.006897 MPa.  
For pound-inch units: 1 mm = 0.03937 inches, 1 N = 0.2248 lbf, 1 MPa = 145.0 psi

<sup>1</sup> Temperature range A: Maximum short term temperature = 130°F (55°C), Maximum long term temperature = 110°F (43°C).  
Temperature range B: Maximum short term temperature = 176°F (80°C), Maximum long term temperature = 110°F (43°C).  
Temperature range C: Maximum short term temperature = 248°F (120°C), Maximum long term temperature = 162°F (72°C).  
Short term elevated concrete temperatures are those that occur over brief intervals, e.g., as a result of diurnal cycling. Long term concrete temperatures are roughly constant over significant periods of time.



Fractional Threaded Rod

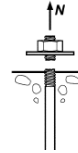

Steel Strength

TABLE 11—STEEL DESIGN INFORMATION FOR FRACTIONAL THREADED ROD

DESIGN INFORMATION		Symbol	Units	Nominal rod diameter (in.) <sup>1</sup>						
				3/8	1/2	5/8	3/4	7/8	1	1 1/4
Rod O.D.		<i>d</i>	in. (mm)	0.375 (9.5)	0.5 (12.7)	0.625 (15.9)	0.75 (19.1)	0.875 (22.2)	1 (25.4)	1.25 (31.8)
Rod effective cross-sectional area		<i>A<sub>se</sub></i>	in. <sup>2</sup> (mm <sup>2</sup> )	0.0775 (50)	0.1419 (92)	0.2260 (146)	0.3345 (216)	0.4617 (298)	0.6057 (391)	0.9691 (625)
ISO 898-1 Class 5.8	Nominal strength as governed by steel strength	<i>N<sub>sa</sub></i>	lb (kN)	5,620 (25.0)	10,290 (45.8)	16,385 (72.9)	24,250 (107.9)	33,470 (148.9)	43,910 (195.3)	70,260 (312.5)
		<i>V<sub>sa</sub></i>	lb (kN)	3,370 (15.0)	6,175 (27.5)	9,830 (43.7)	14,550 (64.7)	20,085 (89.3)	26,345 (117.2)	42,155 (187.5)
	Reduction for seismic shear	<i>α<sub>v,seis</sub></i>	-	1.00						
	Strength reduction factor <i>φ</i> for tension <sup>2</sup>	<i>φ</i>	-	0.65						
		Strength reduction factor <i>φ</i> for shear <sup>2</sup>	<i>φ</i>	0.60						
ASTM A193 B7	Nominal strength as governed by steel strength	<i>N<sub>sa</sub></i>	lb (kN)	9,685 (43.1)	17,735 (78.9)	28,250 (125.7)	41,810 (186.0)	57,710 (256.7)	75,710 (336.8)	121,135 (538.8)
		<i>V<sub>sa</sub></i>	lb (kN)	5,810 (25.9)	10,640 (47.3)	16,950 (75.4)	25,085 (111.6)	34,625 (154.0)	45,425 (202.1)	72,680 (323.3)
	Reduction for seismic shear	<i>α<sub>v,seis</sub></i>	-	1.00						
	Strength reduction factor <i>φ</i> for tension <sup>2</sup>	<i>φ</i>	-	0.75						
		Strength reduction factor <i>φ</i> for shear <sup>2</sup>	<i>φ</i>	0.65						
ASTM F1554 Gr. 36	Nominal strength as governed by steel strength	<i>N<sub>sa</sub></i>	lb (kN)	- (-)	8,230 (36.6)	13,110 (58.3)	19,400 (86.3)	26,780 (119.1)	35,130 (156.3)	56,210 (250.0)
		<i>V<sub>sa</sub></i>	lb (kN)	- (-)	4,940 (22.0)	7,865 (35.0)	11,640 (51.8)	16,070 (71.5)	21,080 (93.8)	33,725 (150.0)
	Reduction factor, seismic shear	<i>α<sub>v,seis</sub></i>	-	0.6						
	Strength reduction factor <i>φ</i> for tension <sup>2</sup>	<i>φ</i>	-	0.75						
		Strength reduction factor <i>φ</i> for shear <sup>2</sup>	<i>φ</i>	0.65						
ASTM F1554 Gr. 55	Nominal strength as governed by steel strength	<i>N<sub>sa</sub></i>	lb (kN)	- (-)	10,645 (47.4)	16,950 (75.4)	25,090 (111.6)	34,630 (154.0)	45,430 (202.1)	72,685 (323.3)
		<i>V<sub>sa</sub></i>	lb (kN)	- (-)	6,385 (28.4)	10,170 (45.2)	15,055 (67.0)	20,780 (92.4)	27,260 (121.3)	43,610 (194.0)
	Reduction factor, seismic shear	<i>α<sub>v,seis</sub></i>	-	1.00						
	Strength reduction factor <i>φ</i> for tension <sup>2</sup>	<i>φ</i>	-	0.75						
		Strength reduction factor <i>φ</i> for shear <sup>2</sup>	<i>φ</i>	0.65						
ASTM F1554 Gr. 105	Nominal strength as governed by steel strength	<i>N<sub>sa</sub></i>	lb (kN)	- (-)	17,740 (78.9)	28,250 (125.7)	41,815 (186.0)	57,715 (256.7)	75,715 (336.8)	121,135 (538.8)
		<i>V<sub>sa</sub></i>	lb (kN)	- (-)	10,645 (47.4)	16,950 (75.4)	25,090 (111.6)	34,630 (154.0)	45,430 (202.1)	72,680 (323.3)
	Reduction factor, seismic shear	<i>α<sub>v,seis</sub></i>	-	1.00						
	Strength reduction factor <i>φ</i> for tension <sup>2</sup>	<i>φ</i>	-	0.75						
		Strength reduction factor <i>φ</i> for shear <sup>2</sup>	<i>φ</i>	0.65						
ASTM F593, CW Stainless	Nominal strength as governed by steel strength	<i>N<sub>sa</sub></i>	lb (kN)	7,750 (34.5)	14,190 (63.1)	22,600 (100.5)	28,435 (126.5)	39,245 (174.6)	51,485 (229.0)	- (-)
		<i>V<sub>sa</sub></i>	lb (kN)	4,650 (20.7)	8,515 (37.9)	13,560 (60.3)	17,060 (75.9)	23,545 (104.7)	30,890 (137.4)	- (-)
	Reduction factor, seismic shear	<i>α<sub>v,seis</sub></i>	-	0.80						
	Strength reduction factor <i>φ</i> for tension <sup>2</sup>	<i>φ</i>	-	0.65						
		Strength reduction factor <i>φ</i> for shear <sup>2</sup>	<i>φ</i>	0.60						
ASTM A193, Gr. 8(M), Class 1 Stainless	Nominal strength as governed by steel strength	<i>N<sub>sa</sub></i>	lb (kN)	- (-)	- (-)	- (-)	- (-)	- (-)	- (-)	55,240 (245.7)
		<i>V<sub>sa</sub></i>	lb (kN)	- (-)	- (-)	- (-)	- (-)	- (-)	- (-)	33,145 (147.4)
	Reduction factor, seismic shear	<i>α<sub>v,seis</sub></i>	-	0.80						
	Strength reduction factor <i>φ</i> for tension <sup>2</sup>	<i>φ</i>	-	0.75						
		Strength reduction factor <i>φ</i> for shear <sup>2</sup>	<i>φ</i>	0.65						

For **SI**: 1 inch = 25.4 mm, 1 lbf = 4.448 N. For **pound-inch** units: 1 mm = 0.03937 inches, 1 N = 0.2248 lbf

<sup>1</sup> Values provided for common rod material types are based on specified strengths and calculated in accordance with ACI 318-19 Eq. (17.6.1.2) and Eq. (17.7.1.2b), ACI 318-14 Eq. (17.4.1.2) and Eq. (17.5.1.2b) or ACI 318-11 Eq. (D-2) and Eq. (D-29). Nuts and washers must be appropriate for the rod.

<sup>2</sup> The strength reduction factor applies when the load combinations from the IBC or ACI 318 are used and the requirements of ACI 318-19 17.5.3, ACI 318-14 17.3.3 or ACI 318-11 D.4.3, as applicable, are met. If the load combinations of ACI 318-11 Appendix C are used, the appropriate strength reduction factor must be determined in accordance with ACI 318-11 D.4.4.

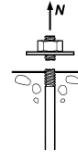

Fractional Reinforcing Bars

Steel Strength

TABLE 11A—STEEL DESIGN INFORMATION FOR FRACTIONAL REINFORCING BARS

DESIGN INFORMATION		Symbol	Units	Nominal Reinforcing bar size (Rebar)							
				#3	#4	#5	#6	#7	#8	#9	#10
Nominal bar diameter		$d$	in. (mm)	$\frac{3}{8}$ (9.5)	$\frac{1}{2}$ (12.7)	$\frac{5}{8}$ (15.9)	$\frac{3}{4}$ (19.1)	$\frac{7}{8}$ (22.2)	1 (25.4)	1.128 (28.7)	1.270 (32.3)
Bar effective cross-sectional area		$A_{se}$	in. <sup>2</sup> (mm <sup>2</sup> )	0.11 (71)	0.2 (129)	0.31 (199)	0.44 (284)	0.6 (387)	0.79 (510)	1.0 (645)	1.27 (819)
ASTM A615 Grade 60	Nominal strength as governed by steel strength	$N_{sa}$	lb (kN)	6,600 (29.4)	12,000 (53.4)	18,600 (82.7)	26,400 (117.4)	36,000 (160.1)	47,400 (210.9)	60,000 (266.9)	76,200 (339.0)
		$V_{sa}$	lb (kN)	3,960 (17.6)	7,200 (32.0)	11,160 (49.6)	15,840 (70.5)	21,600 (96.1)	28,440 (126.5)	36,000 (160.1)	45,720 (203.4)
	Reduction for seismic shear	$\alpha_{V,seis}$	-	0.70							
	Strength reduction factor $\phi$ for tension <sup>2</sup>	$\phi$	-	0.65							
	Strength reduction factor $\phi$ for shear <sup>2</sup>	$\phi$	-	0.60							
ASTM A615 Grade 60	Nominal strength as governed by steel strength	$N_{sa}$	lb (kN)	8,800 (39.1)	16,000 (71.2)	24,800 (110.3)	35,200 (156.6)	48,000 (213.5)	63,200 (281.1)	80,000 (355.9)	101,600 (451.9)
		$V_{sa}$	lb (kN)	5,280 (23.5)	9,600 (42.7)	14,880 (66.2)	21,120 (93.9)	28,800 (128.1)	37,920 (168.7)	48,000 (213.5)	60,960 (271.2)
	Reduction for seismic shear	$\alpha_{V,seis}$	-	0.70							
	Strength reduction factor $\phi$ for tension <sup>2</sup>	$\phi$	-	0.65							
	Strength reduction factor $\phi$ for shear <sup>2</sup>	$\phi$	-	0.60							
ASTM A706 Grade 60	Nominal strength as governed by steel strength	$N_{sa}$	lb (kN)	8,800 (39.1)	16,000 (71.2)	24,800 (110.3)	35,200 (156.6)	48,000 (213.5)	63,200 (281.1)	80,000 (355.9)	101,600 (452.0)
		$V_{sa}$	lb (kN)	5,280 (23.5)	9,600 (42.7)	14,880 (66.2)	21,120 (94.0)	28,800 (128.1)	37,920 (168.7)	48,000 (213.5)	60,960 (271.2)
	Reduction for seismic shear	$\alpha_{V,seis}$		0.70							
	Strength reduction factor $\phi$ for tension <sup>2</sup>	$\phi$		0.75							
	Strength reduction factor $\phi$ for shear <sup>2</sup>	$\phi$		0.65							

For SI: 1 inch = 25.4 mm, 1 lbf = 4.448 N. For pound-inch units: 1 mm = 0.03937 inches, 1 N = 0.2248 lbf

<sup>1</sup> Values provided for common rod material types are based on specified strengths and calculated in accordance with ACI 318-19 Eq. (17.6.1.2) and Eq (17.7.1.2b), ACI 318-14 Eq. (17.4.1.2) and Eq (17.5.1.2b) or ACI 318-11 Eq. (D-2) and Eq. (D-29). Nuts and washers must be appropriate for the rod.

<sup>2</sup> The strength reduction factor applies when the load combinations from the IBC or ACI 318 are used and the requirements of ACI 318-19 17.5.3, ACI 318-14 17.3.3 or ACI 318-11 D.4.3, as applicable, are met. If the load combinations of ACI 318-11 Appendix C are used, the appropriate strength reduction factor must be determined in accordance with ACI 318-11 D.4.4.



Fractional Threaded Rod and Reinforcing Bars

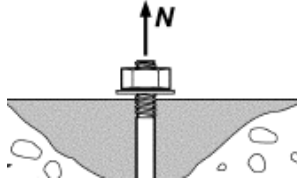

Concrete Breakout Strength

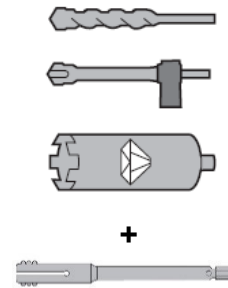

Carbide Bit or Hilti Hollow Carbide Bit or Diamond Core Bit with Roughening Tool

**TABLE 12—CONCRETE BREAKOUT DESIGN INFORMATION FOR FRACTIONAL THREADED ROD AND REINFORCING BARS IN HOLES DRILLED WITH A HAMMER DRILL AND CARBIDE BIT (OR HILTI HOLLOW CARBIDE DRILL BIT) OR CORE DRILLED WITH A DIAMOND CORE BIT AND ROUGHENED WITH A HILTI ROUGHENING TOOL<sup>1</sup>**

DESIGN INFORMATION	Symbol	Units	Nominal rod diameter (in.) / Reinforcing bar size							
			3/8 or #3	1/2 or #4	5/8 or #5	3/4 or #6	7/8 or #7	1 or #8	#9	1 1/4 or #10
Effectiveness factor for cracked concrete	$k_{c,cr}$	in-lb (SI)	17 (7.1)							
Effectiveness factor for uncracked concrete	$k_{c,uncr}$	in-lb (SI)	24 (10)							
Minimum Embedment	$h_{ef,min}$	in. (mm)	2 3/8 (60)	2 3/4 (70)	3 1/8 (79)	3 1/2 (89)	3 1/2 (89)	4 (102)	4 1/2 (114)	5 (127)
Maximum Embedment	$h_{ef,max}$	in. (mm)	7 1/2 (191)	10 (254)	12 1/2 (318)	15 (381)	17 1/2 (445)	20 (508)	22 1/2 (572)	25 (635)
Min. anchor spacing <sup>3</sup>	$s_{min}$	in. (mm)	1 7/8 (48)	2 1/2 (64)	3 1/8 (79)	3 3/4 (95)	4 3/8 (111)	5 (127)	5 5/8 (143)	6 1/4 (159)
Min. edge distance (Threaded rods)	$c_{min}$	in. (mm)	1 3/4 (45)	1 3/4 (45)	2 <sup>(3)</sup> (50) <sup>(3)</sup>	2 1/8 <sup>(3)</sup> (55) <sup>(3)</sup>	2 1/4 <sup>(3)</sup> (60) <sup>(3)</sup>	2 3/4 <sup>(3)</sup> (70) <sup>(3)</sup>	n/a	3 1/8 <sup>(3)</sup> (80) <sup>(3)</sup>
Min. edge distance (Reinforcing bars) <sup>3</sup>	$c_{min}$	-	5d; or see Section 4.1.9.2 of this report for design with reduced minimum edge distances							
Minimum concrete thickness	$h_{min}$	in. (mm)	$h_{ef} + 1 1/4$ ( $h_{ef} + 30$ )		$h_{ef} + 2d_o^{(4)}$					
Critical edge distance – splitting (for uncracked concrete)	$c_{ac}$	-	See Section 4.1.10.2 of this report.							
Strength reduction factor for tension, concrete failure modes, Condition B (supplemental reinforcement not present) <sup>2</sup>	$\phi$	-	0.65							
Strength reduction factor for shear, concrete failure modes, Condition B (supplemental reinforcement not present) <sup>2</sup>	$\phi$	-	0.70							

For SI: 1 inch ≡ 25.4 mm, 1 lbf = 4.448 N, 1 psi = 0.006897 MPa.  
 For pound-inch units: 1 mm = 0.03937 inches, 1 N = 0.2248 lbf, 1 MPa = 145.0 psi

<sup>1</sup> Additional setting information is described in Figure 6, Manufacturers Printed Installation Instructions (MPII).  
<sup>2</sup> The strength reduction factor applies when the load combinations from the IBC or ACI 318 are used and the requirements of ACI 318-19 17.5.3, ACI 318-14 17.3.3 or ACI 318-11 D.4.3, as applicable, are met. If the load combinations of ACI 318-11 Appendix C are used, the appropriate strength reduction factor must be determined in accordance with ACI 318-11 D.4.4.  
<sup>3</sup> For installations with 1 3/4-inch edge distance, refer to Section 4.1.9.2 for spacing and maximum torque requirements.  
<sup>4</sup>  $d_o$  = hole diameter.

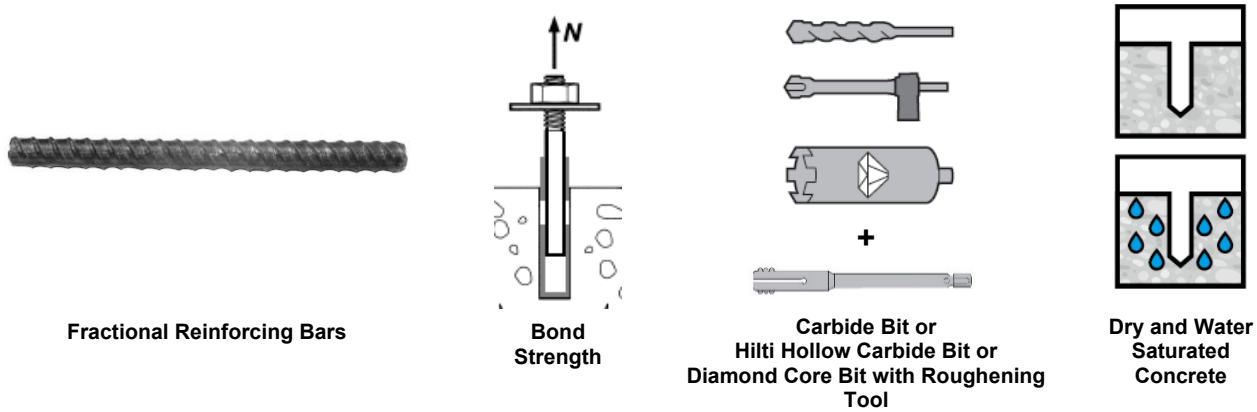

**TABLE 13—BOND STRENGTH DESIGN INFORMATION FOR FRACTIONAL REINFORCING BARS IN HOLES DRILLED WITH A HAMMER DRILL AND CARBIDE BIT (OR HILTI HOLLOW CARBIDE DRILL BIT) OR CORE DRILLED WITH A DIAMOND CORE BIT AND ROUGHENED WITH A HILTI ROUGHENING TOOL<sup>1</sup>**

DESIGN INFORMATION		Symbol	Units	Nominal reinforcing bar size							
				#3	#4	#5	#6	#7	#8	#9	#10
Minimum Embedment		$h_{ef,min}$	in. (mm)	2 <sup>3</sup> / <sub>8</sub> (60)	2 <sup>3</sup> / <sub>4</sub> (70)	3 <sup>1</sup> / <sub>8</sub> (79)	3 <sup>1</sup> / <sub>2</sub> (89)	3 <sup>1</sup> / <sub>2</sub> (89)	4 (102)	4 <sup>1</sup> / <sub>2</sub> (114)	5 (127)
Maximum Embedment		$h_{ef,max}$	in. (mm)	7 <sup>1</sup> / <sub>2</sub> (191)	10 (254)	12 <sup>1</sup> / <sub>2</sub> (318)	15 (381)	17 <sup>1</sup> / <sub>2</sub> (445)	20 (508)	22 <sup>1</sup> / <sub>2</sub> (572)	25 (635)
Temperature range A <sup>2</sup>	Characteristic bond strength in cracked concrete	$\tau_{k,cr}$	psi (MPa)	1,080 (7.4)	1,080 (7.4)	1,090 (7.5)	1,090 (7.5)	835 (5.7)	840 (5.8)	850 (5.9)	850 (5.9)
	Characteristic bond strength in uncracked concrete	$\tau_{k,uncr}$	psi (MPa)	1,560 (10.8)	1,560 (10.8)	1,560 (10.8)	1,560 (10.8)	1,560 (10.8)	1,560 (10.8)	1,560 (10.8)	1,560 (10.8)
Temperature range B <sup>2</sup>	Characteristic bond strength in cracked concrete	$\tau_{k,cr}$	psi (MPa)	1,080 (7.4)	1,080 (7.4)	1,090 (7.5)	1,090 (7.5)	835 (5.7)	840 (5.8)	850 (5.9)	850 (5.9)
	Characteristic bond strength in uncracked concrete	$\tau_{k,uncr}$	psi (MPa)	1,560 (10.8)	1,560 (10.8)	1,560 (10.8)	1,560 (10.8)	1,560 (10.8)	1,560 (10.8)	1,560 (10.8)	1,560 (10.8)
Temperature range C <sup>2</sup>	Characteristic bond strength in cracked concrete	$\tau_{k,cr}$	psi (MPa)	885 (6.1)	890 (6.1)	895 (6.2)	895 (6.2)	685 (4.7)	690 (4.8)	700 (4.8)	700 (4.8)
	Characteristic bond strength in uncracked concrete	$\tau_{k,uncr}$	psi (MPa)	1,280 (8.8)	1,280 (8.8)	1,280 (8.8)	1,280 (8.8)	1,280 (8.8)	1,280 (8.8)	1,280 (8.8)	1,280 (8.8)
Permissible installation conditions	Dry concrete and water saturated concrete 	Anchor Category	-	1							
		$\phi_t, \phi_{ws}$	-	0.65							
Reduction for seismic tension	Hammer drilled 	$\alpha_{N,seis}$	-	0.80			0.85	0.90	0.95	1.0	
	Core drilled + roughening 	$\alpha_{N,seis}$	-	N/A	0.71	0.77	0.82	0.95	0.79	0.83	

For SI: 1 inch ≡ 25.4 mm, 1 lbf = 4.448 N, 1 psi = 0.006897 MPa.  
 For pound-inch units: 1 mm = 0.03937 inches, 1 N = 0.2248 lbf, 1 MPa = 145.0 psi

<sup>1</sup> Bond strength values correspond to concrete compressive strength  $f'_c = 2,500$  psi (17.2 MPa). For concrete compressive strength,  $f'_c$ , between 2,500 psi (17.2 MPa) and 8,000 psi (55.2 MPa), the tabulated characteristic bond strength may be increased by a factor of  $(f'_c / 2,500)^{0.1}$  [For SI:  $(f'_c / 17.2)^{0.1}$ ]. See Section 4.1.4 of this report for bond strength determination.

<sup>2</sup> Temperature range A: Maximum short term temperature = 130°F (55°C), Maximum long term temperature = 110°F (43°C).  
 Temperature range B: Maximum short term temperature = 176°F (80°C), Maximum long term temperature = 110°F (43°C).  
 Temperature range C: Maximum short term temperature = 248°F (120°C), Maximum long term temperature = 162°F (72°C).  
 Short term elevated concrete temperatures are those that occur over brief intervals, e.g., as a result of diurnal cycling. Long term concrete temperatures are roughly constant over significant periods of time.

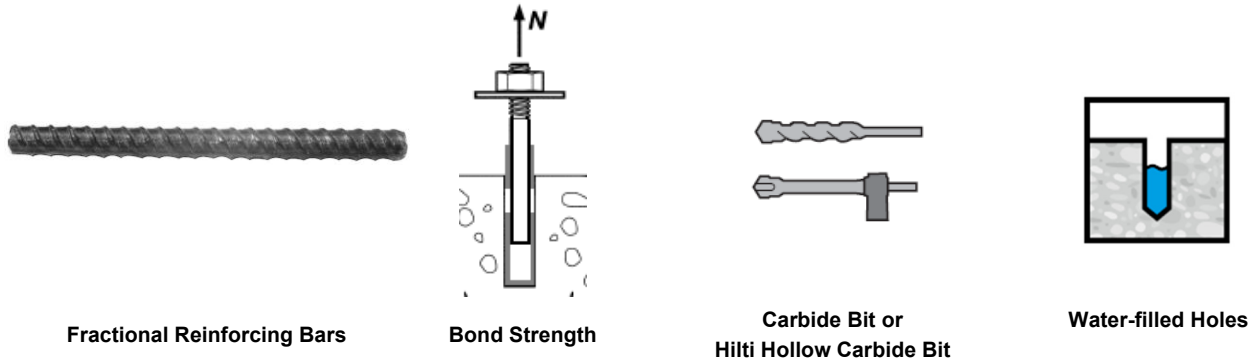

**TABLE 14—BOND STRENGTH DESIGN INFORMATION FOR FRACTIONAL REINFORCING BARS IN HOLES DRILLED WITH A HAMMER DRILL AND CARBIDE BIT (OR HILTI HOLLOW CARBIDE DRILL BIT)**

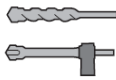
DESIGN INFORMATION		Symbol	Units	Nominal reinforcing bar size							
				#3	#4	#5	#6	#7	#8	#9	#10
Minimum Embedment		$h_{ef,min}$	in. (mm)	2 <sup>3</sup> / <sub>8</sub> (60)	2 <sup>3</sup> / <sub>4</sub> (70)	3 <sup>1</sup> / <sub>8</sub> (79)	3 <sup>1</sup> / <sub>2</sub> (89)	3 <sup>1</sup> / <sub>2</sub> (89)	4 (102)	4 <sup>1</sup> / <sub>2</sub> (114)	5 (127)
Maximum Embedment		$h_{ef,max}$	in. (mm)	7 <sup>1</sup> / <sub>2</sub> (191)	10 (254)	12 <sup>1</sup> / <sub>2</sub> (318)	15 (381)	17 <sup>1</sup> / <sub>2</sub> (445)	20 (508)	22 <sup>1</sup> / <sub>2</sub> (572)	25 (635)
Temperature range A <sup>2</sup>	Characteristic bond strength in cracked concrete	$\tau_{k,cr}$	psi (MPa)	1,050 (7.2)	1,050 (7.2)	1,070 (7.4)	1,070 (7.4)	820 (5.7)	820 (5.7)	830 (5.7)	830 (5.7)
	Characteristic bond strength in uncracked concrete	$\tau_{k,uncr}$	psi (MPa)	1,520 (10.5)	1,520 (10.5)	1,520 (10.5)	1,520 (10.5)	1,520 (10.5)	1,520 (10.5)	1,520 (10.5)	1,520 (10.5)
Temperature range B <sup>2</sup>	Characteristic bond strength in cracked concrete	$\tau_{k,cr}$	psi (MPa)	1,050 (7.2)	1,050 (7.2)	1,070 (7.4)	1,070 (7.4)	820 (5.7)	820 (5.7)	830 (5.7)	830 (5.7)
	Characteristic bond strength in uncracked concrete	$\tau_{k,uncr}$	psi (MPa)	1,520 (10.5)	1,520 (10.5)	1,520 (10.5)	1,520 (10.5)	1,520 (10.5)	1,520 (10.5)	1,520 (10.5)	1,520 (10.5)
Temperature range C <sup>2</sup>	Characteristic bond strength in cracked concrete	$\tau_{k,cr}$	psi (MPa)	865 (6.0)	865 (6.0)	875 (6.1)	875 (6.1)	670 (4.6)	680 (4.7)	680 (4.7)	680 (4.7)
	Characteristic bond strength in uncracked concrete	$\tau_{k,uncr}$	psi (MPa)	1,250 (8.6)	1,250 (8.6)	1,250 (8.6)	1,250 (8.6)	1,250 (8.6)	1,250 (8.6)	1,250 (8.6)	1,250 (8.6)
Permissible installation conditions	Water-filled Holes 	Anchor Category	-	3							
		$\phi_M$	-	0.45							
Reduction for seismic tension	Hammer drilled 	$\alpha_{N,seis}$	-	0.80			0.85	0.90	0.95	1.0	

For SI: 1 inch ≅ 25.4 mm, 1 lbf = 4.448 N, 1 psi = 0.006897 MPa.  
 For pound-inch units: 1 mm = 0.03937 inches, 1 N = 0.2248 lbf, 1 MPa = 145.0 psi

<sup>1</sup> Bond strength values correspond to concrete compressive strength  $f_c = 2,500$  psi (17.2 MPa). For concrete compressive strength,  $f_c$ , between 2,500 psi (17.2 MPa) and 8,000 psi (55.2 MPa), the tabulated characteristic bond strength may be increased by a factor of  $(f_c / 2,500)^{0.1}$  [For SI:  $(f_c / 17.2)^{0.1}$ ]. See Section 4.1.4 of this report for bond strength determination.

<sup>2</sup> Temperature range A: Maximum short term temperature = 130°F (55°C), Maximum long term temperature = 110°F (43°C).  
 Temperature range B: Maximum short term temperature = 176°F (80°C), Maximum long term temperature = 110°F (43°C).  
 Temperature range C: Maximum short term temperature = 248°F (120°C), Maximum long term temperature = 162°F (72°C).  
 Short term elevated concrete temperatures are those that occur over brief intervals, e.g., as a result of diurnal cycling. Long term concrete temperatures are roughly constant over significant periods of time.



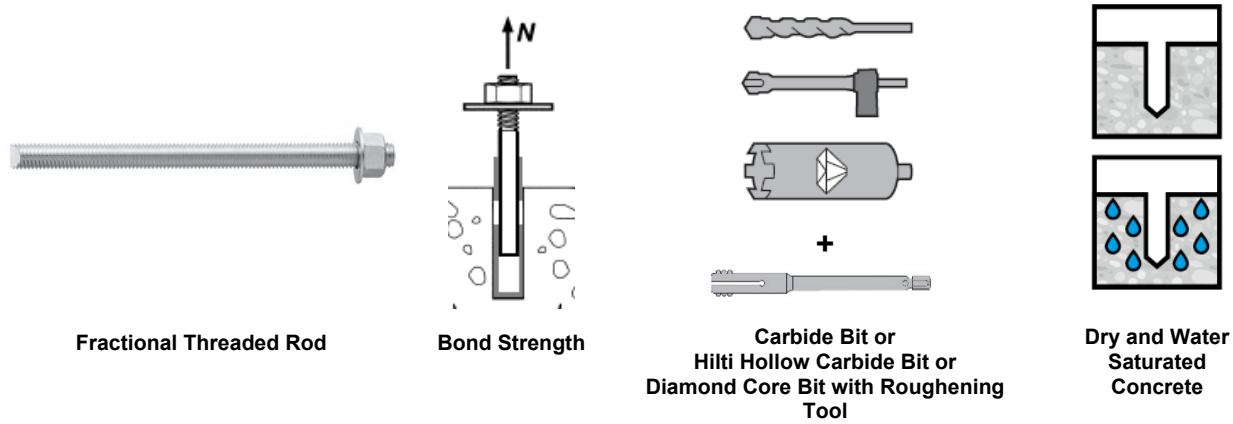

**TABLE 15—BOND STRENGTH DESIGN INFORMATION FOR FRACTIONAL THREADED ROD IN HOLES DRILLED WITH A HAMMER DRILL AND CARBIDE BIT (OR HILTI HOLLOW CARBIDE DRILL BIT) OR CORE DRILLED WITH A DIAMOND CORE BIT AND ROUGHENED WITH A HILTI ROUGHENING TOOL<sup>1</sup>**

DESIGN INFORMATION		Symbol	Units	Nominal rod diameter (in.)						
				3/8	1/2	5/8	3/4	7/8	1	1 1/4
Minimum Embedment		$h_{ef,min}$	in. (mm)	2 3/8 (60)	2 3/4 (70)	3 1/8 (79)	3 1/2 (89)	3 1/2 (89)	4 (102)	5 (127)
Maximum Embedment		$h_{ef,max}$	in. (mm)	7 1/2 (191)	10 (254)	12 1/2 (318)	15 (381)	17 1/2 (445)	20 (508)	25 (635)
Temperature range A <sup>2</sup>	Characteristic bond strength in cracked concrete	$\tau_{k,cr}$	psi (MPa)	1,045 (7.2)	1,135 (7.8)	1,170 (8.1)	1,260 (8.7)	1,290 (8.9)	1,325 (9.1)	1,380 (9.5)
	Characteristic bond strength in uncracked concrete	$\tau_{k,uncr}$	psi (MPa)	2,220 (15.3)	2,220 (15.3)	2,220 (15.3)	2,220 (15.3)	2,220 (15.3)	2,220 (15.3)	2,220 (15.3)
Temperature range B <sup>2</sup>	Characteristic bond strength in cracked concrete	$\tau_{k,cr}$	psi (MPa)	1,045 (7.2)	1,135 (7.8)	1,170 (8.1)	1,260 (8.7)	1,290 (8.9)	1,325 (9.1)	1,380 (9.5)
	Characteristic bond strength in uncracked concrete	$\tau_{k,uncr}$	psi (MPa)	2,220 (15.3)	2,220 (15.3)	2,220 (15.3)	2,220 (15.3)	2,220 (15.3)	2,220 (15.3)	2,220 (15.3)
Temperature range C <sup>2</sup>	Characteristic bond strength in cracked concrete	$\tau_{k,cr}$	psi (MPa)	855 (5.9)	930 (6.4)	960 (6.6)	1,035 (7.1)	1,055 (7.3)	1,085 (7.5)	1,130 (7.8)
	Characteristic bond strength in uncracked concrete	$\tau_{k,uncr}$	psi (MPa)	1,820 (12.6)	1,820 (12.6)	1,820 (12.6)	1,820 (12.6)	1,820 (12.6)	1,820 (12.6)	1,820 (12.6)
Permissible installation conditions	Dry and water saturated concrete	Anchor Category	-	1						
		$\phi_{ds}, \phi_{ws}$	-	0.65						
Reduction for seismic tension	 Hammer drilled	$\alpha_{N,seis}$	-	0.88	0.99	0.99	1.0	1.0	0.95	0.99
	 Core drilled + roughening	$\alpha_{N,seis}$	-	N/A		0.88	0.96	0.96	1.0	0.82

For SI: 1 inch ≡ 25.4 mm, 1 lbf = 4.448 N, 1 psi = 0.006897 MPa.  
For pound-inch units: 1 mm = 0.03937 inches, 1 N = 0.2248 lbf, 1 MPa = 145.0 psi

<sup>1</sup> Bond strength values correspond to concrete compressive strength  $f'_c = 2,500$  psi (17.2 MPa). For concrete compressive strength,  $f'_c$ , between 2,500 psi (17.2 MPa) and 8,000 psi (55.2 MPa), the tabulated characteristic bond strength may be increased by a factor of  $(f'_c / 2,500)^{0.1}$  [For SI:  $(f'_c / 17.2)^{0.1}$ ]. See Section 4.1.4 of this report for bond strength determination.

<sup>2</sup> Temperature range A: Maximum short term temperature = 130°F (55°C), Maximum long term temperature = 110°F (43°C).

Temperature range B: Maximum short term temperature = 176°F (80°C), Maximum long term temperature = 110°F (43°C).

Temperature range C: Maximum short term temperature = 248°F (120°C), Maximum long term temperature = 162°F (72°C).

Short term elevated concrete temperatures are those that occur over brief intervals, e.g., as a result of diurnal cycling. Long term concrete temperatures are roughly constant over significant periods of time.

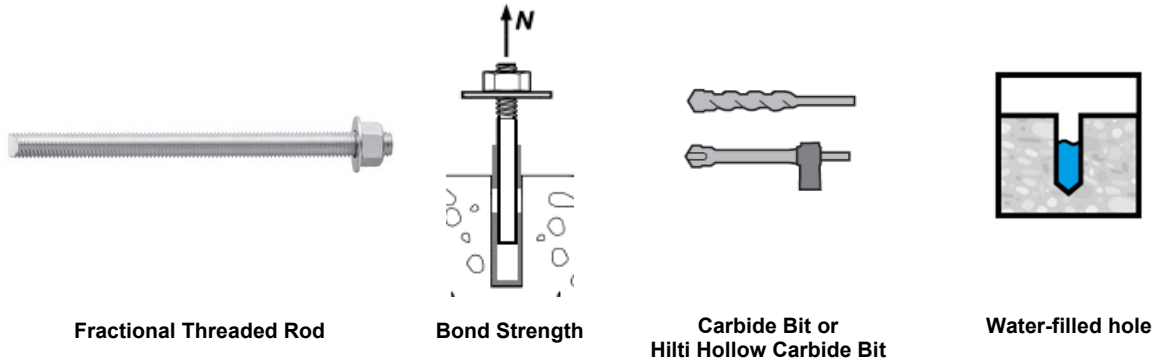

**TABLE 16—BOND STRENGTH DESIGN INFORMATION FOR FRACTIONAL THREADED ROD IN HOLES DRILLED WITH A HAMMER DRILL AND CARBIDE BIT (OR HILTI HOLLOW CARBIDE DRILL BIT)**

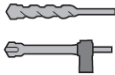
DESIGN INFORMATION		Symbol	Units	Nominal rod diameter (in.)						
				3/8	1/2	5/8	3/4	7/8	1	1 1/4
Minimum Embedment		$h_{ef,min}$	in. (mm)	2 3/8 (60)	2 3/4 (70)	3 1/8 (79)	3 1/2 (89)	3 1/2 (89)	4 (102)	5 (127)
Maximum Embedment		$h_{ef,max}$	in. (mm)	7 1/2 (191)	10 (254)	12 1/2 (318)	15 (381)	17 1/2 (445)	20 (508)	25 (635)
Temperature range A <sup>2</sup>	Characteristic bond strength in cracked concrete	$\tau_{k,cr}$	psi (MPa)	825 (5.7)	875 (6.0)	865 (6.0)	910 (6.3)	890 (6.1)	885 (6.1)	840 (5.8)
	Characteristic bond strength in uncracked concrete	$\tau_{k,uncr}$	psi (MPa)	1,755 (12.1)	1,710 (11.8)	1,645 (11.3)	1,600 (11)	1,535 (10.6)	1,490 (10.3)	1,355 (9.3)
Temperature range B <sup>2</sup>	Characteristic bond strength in cracked concrete	$\tau_{k,cr}$	psi (MPa)	825 (5.7)	875 (6.0)	865 (6.0)	910 (6.3)	890 (6.1)	885 (6.1)	840 (5.8)
	Characteristic bond strength in uncracked concrete	$\tau_{k,uncr}$	psi (MPa)	1,755 (12.1)	1,710 (11.8)	1,645 (11.3)	1,600 (11.0)	1,535 (10.6)	1,490 (10.3)	1,355 (9.3)
Temperature range C <sup>2</sup>	Characteristic bond strength in cracked concrete	$\tau_{k,cr}$	psi (MPa)	675 (4.7)	715 (4.9)	710 (4.9)	745 (5.1)	730 (5.0)	730 (5.0)	690 (4.8)
	Characteristic bond strength in uncracked concrete	$\tau_{k,uncr}$	psi (MPa)	1,440 (9.9)	1,405 (9.7)	1,350 (9.3)	1,310 (9.0)	1,260 (8.7)	1,220 (8.4)	1,110 (7.7)
Permissible installation conditions	 Water-filled hole	Anchor Category	-	3						
		$\phi_{wf}$	-	0.45						
Reduction for seismic tension	 Hammer drilled	$\alpha_{N,seis}$	-	0.88	0.99	0.99	1.0	1.0	0.95	0.99

For SI: 1 inch ≅ 25.4 mm, 1 lbf = 4.448 N, 1 psi = 0.006897 MPa.

For pound-inch units: 1 mm = 0.03937 inches, 1 N = 0.2248 lbf, 1 MPa = 145.0 psi

<sup>1</sup> Bond strength values correspond to concrete compressive strength  $f'_c = 2,500$  psi (17.2 MPa). For concrete compressive strength,  $f'_c$ , between 2,500 psi (17.2 MPa) and 8,000 psi (55.2 MPa), the tabulated characteristic bond strength may be increased by a factor of  $(f'_c / 2,500)^{0.1}$  [For SI:  $(f'_c / 17.2)^{0.1}$ ]. See Section 4.1.4 of this report for bond strength determination.

<sup>2</sup> Temperature range A: Maximum short-term temperature = 130°F (55°C), Maximum long-term temperature = 110°F (43°C).

Temperature range B: Maximum short-term temperature = 176°F (80°C), Maximum long-term temperature = 110°F (43°C).

Temperature range C: Maximum short-term temperature = 248°F (120°C), Maximum long-term temperature = 162°F (72°C).

short-term elevated concrete temperatures are those that occur over brief intervals, e.g., as a result of diurnal cycling. long-term concrete temperatures are roughly constant over significant periods of time.

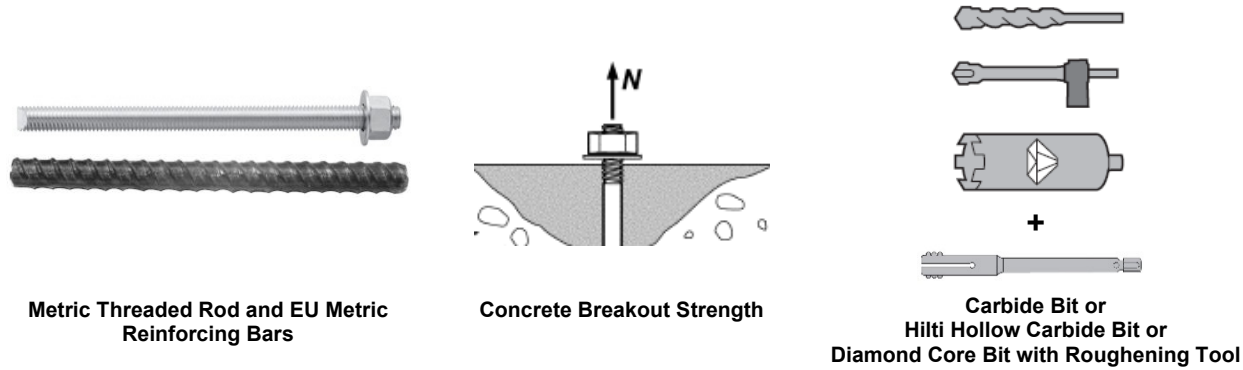

TABLE 17—STEEL DESIGN INFORMATION FOR METRIC THREADED ROD AND EU METRIC REINFORCING BARS

DESIGN INFORMATION			Symbol	Units	Nominal rod diameter (mm) <sup>1</sup>							
					10	12	16	20	24	27	30	
Rod Outside Diameter			<i>d</i>	mm (in.)	10 (0.39)	12 (0.47)	16 (0.63)	20 (0.79)	24 (0.94)	27 (1.06)	30 (1.18)	
Rod effective cross-sectional area			<i>A<sub>se</sub></i>	mm <sup>2</sup> (in. <sup>2</sup> )	58.0 (0.090)	84.3 (0.131)	157 (0.243)	245 (0.380)	353 (0.547)	459 (0.711)	561 (0.870)	
ISO 898-1 Class 5.8	Nominal strength as governed by steel strength		<i>N<sub>sa</sub></i>	kN (lb)	29.0 (6,519)	42.0 (9,476)	78.5 (17,647)	122.5 (27,539)	176.5 (39,679)	229.5 (51,594)	280.5 (63,059)	
			<i>V<sub>sa</sub></i>	kN (lb)	14.5 (3,260)	25.5 (5,685)	47.0 (10,588)	73.5 (16,523)	106.0 (23,807)	137.5 (30,956)	168.5 (37,835)	
	Reduction for seismic shear		<i>α<sub>V,seis</sub></i>	-	1.00							
	Strength reduction factor for tension <sup>2</sup>		<i>φ</i>	-	0.65							
	Strength reduction factor for shear <sup>2</sup>		<i>φ</i>	-	0.60							
ISO 898-1 Class 8.8	Nominal strength as governed by steel strength		<i>N<sub>sa</sub></i>	kN (lb)	46.5 (10,431)	67.5 (15,161)	125.5 (28,236)	196.0 (44,063)	282.5 (63,486)	367.0 (82,550)	449.0 (100,894)	
			<i>V<sub>sa</sub></i>	kN (lb)	23.0 (5,216)	40.5 (9,097)	75.5 (16,942)	117.5 (26,438)	169.5 (38,092)	220.5 (49,530)	269.5 (60,537)	
	Reduction for seismic shear		<i>α<sub>V,seis</sub></i>	-	1.00							
	Strength reduction factor for tension <sup>2</sup>		<i>φ</i>	-	0.65							
	Strength reduction factor for shear <sup>2</sup>		<i>φ</i>	-	0.60							
ISO 3506-1 Class A4 Stainless <sup>3</sup>	Nominal strength as governed by steel strength		<i>N<sub>sa</sub></i>	kN (lb)	40.6 (9,127)	59.0 (13,266)	109.9 (24,706)	171.5 (38,555)	247.1 (55,550)	183.1 (41,172)	223.8 (50,321)	
			<i>V<sub>sa</sub></i>	kN (lb)	20.3 (4,564)	35.4 (7,960)	65.9 (14,824)	102.9 (23,133)	148.3 (33,330)	109.9 (24,703)	134.3 (30,192)	
	Reduction for seismic shear		<i>α<sub>V,seis</sub></i>	-	0.80							
	Strength reduction factor for tension <sup>2</sup>		<i>φ</i>	-	0.65							
	Strength reduction factor for shear <sup>2</sup>		<i>φ</i>	-	0.60							
DESIGN INFORMATION			Symbol	Units	Reinforcing bar size							
					10	12	14	16	20	25	28	32
Nominal bar diameter			<i>d</i>	mm (in.)	10.0 (0.394)	12.0 (0.472)	14.0 (0.551)	16.0 (0.630)	20.0 (0.787)	25.0 (0.984)	28.0 (1.102)	32.0 (1.260)
Bar effective cross-sectional area			<i>A<sub>se</sub></i>	mm <sup>2</sup> (in. <sup>2</sup> )	78.5 (0.122)	113.1 (0.175)	153.9 (0.239)	201.1 (0.312)	314.2 (0.487)	490.9 (0.761)	615.8 (0.954)	804.2 (1.247)
DIN 488 BSt 550/500	Nominal strength as governed by steel strength		<i>N<sub>sa</sub></i>	kN (lb)	43.0 (9,711)	62.0 (13,984)	84.5 (19,034)	110.5 (24,860)	173.0 (38,844)	270.0 (60,694)	338.5 (76,135)	442.5 (99,441)
			<i>V<sub>sa</sub></i>	kN (lb)	26.0 (5,827)	37.5 (8,390)	51.0 (11,420)	66.5 (14,916)	103.0 (23,307)	162.0 (36,416)	203.0 (45,681)	265.5 (59,665)
	Reduction for seismic shear		<i>α<sub>V,seis</sub></i>	-	0.70							
	Strength reduction factor for tension <sup>2</sup>		<i>φ</i>	-	0.65							
	Strength reduction factor for shear <sup>2</sup>		<i>φ</i>	-	0.60							

For SI: 1 inch ≅ 25.4 mm, 1 lbf = 4.448 N, 1 psi = 0.006897 MPa.  
 For pound-inch units: 1 mm = 0.03937 inches, 1 N = 0.2248 lbf, 1 MPa = 145.0 psi

<sup>1</sup> Values provided for common rod material types are based on specified strengths and calculated in accordance with ACI 318-19 Eq. (17.6.1.2) and Eq (17.7.1.2b), ACI 318-14 Eq. (17.4.1.2) and Eq (17.5.1.2b) or ACI 318-11 Eq. (D-2) and Eq. (D-29). Nuts and washers must be appropriate for the rod.  
<sup>2</sup> The strength reduction factor applies when the load combinations from the IBC or ACI 318 are used and the requirements of ACI 318-19 17.5.3, ACI 318-14 17.3.3 or ACI 318-11 D.4.3, as applicable, are met. If the load combinations of ACI 318-11 Appendix C are used, the appropriate strength reduction factor must be determined in accordance with ACI 318-11 D.4.4.  
<sup>3</sup> A4-70 Stainless (M8- M24); A4-502 Stainless (M27- M30)



**TABLE 18—CONCRETE BREAKOUT DESIGN INFORMATION FOR METRIC THREADED ROD AND EU METRIC REINFORCING BARS IN HOLES DRILLED WITH A HAMMER DRILL AND CARBIDE BIT (OR HILTI HOLLOW CARBIDE DRILL BIT) OR CORE DRILLED WITH A DIAMOND CORE BIT AND ROUGHENED WITH A HILTI ROUGHENING TOOL<sup>1</sup>**

DESIGN INFORMATION	Symbol	Units	Nominal rod diameter (mm)							
			10	12	16	20	24	27	30	
Minimum Embedment	$h_{ef,min}$	mm (in.)	60 (2.4)	70 (2.8)	80 (3.1)	90 (3.5)	96 (3.8)	108 (4.3)	120 (4.7)	
Maximum Embedment	$h_{ef,max}$	mm (in.)	200 (7.9)	240 (9.4)	320 (12.6)	400 (15.7)	480 (18.9)	540 (21.3)	600 (23.6)	
Min. anchor spacing <sup>3</sup>	$s_{min}$	mm (in.)	50 (2.0)	60 (2.4)	80 (3.2)	100 (3.9)	120 (4.7)	135 (5.3)	150 (5.9)	
Min. edge distance <sup>3</sup>	$c_{min}$	-	5d; or see Section 4.1.9.2 of this report for design with reduced minimum edge distances							
Minimum concrete thickness	$h_{min}$	mm (in.)	$h_{ef} + 30$ $(h_{ef} + 1\frac{1}{4})$	$h_{ef} + 2d_o^{(4)}$						
DESIGN INFORMATION	Symbol	Units	Reinforcing bar size							
			10	12	14	16	20	25	28	32
Minimum Embedment	$h_{ef,min}$	mm (in.)	60 (2.4)	70 (2.8)	75 (3.0)	80 (3.1)	90 (3.5)	100 (3.9)	112 (4.4)	128 (5.0)
Maximum Embedment	$h_{ef,max}$	mm (in.)	200 (7.9)	240 (9.4)	280 (11.0)	320 (12.6)	400 (15.7)	500 (19.7)	560 (22.0)	640 (25.2)
Min. anchor spacing <sup>3</sup>	$s_{min}$	mm (in.)	50 (2.0)	60 (2.4)	80 (3.2)	100 (3.9)	120 (4.7)	135 (5.3)	140 (5.5)	160 (6.3)
Min. edge distance <sup>3</sup>	$c_{min}$	-	5d; or see Section 4.1.9 of this report for design with reduced minimum edge distances							
Minimum concrete thickness	$h_{min}$	mm (in.)	$h_{ef} + 30$ $(h_{ef} + 1\frac{1}{4})$	$h_{ef} + 2d_o^{(4)}$						
Critical edge distance – splitting (for uncracked concrete)	$c_{ac}$	-	See Section 4.1.10.2 of this report.							
Effectiveness factor for cracked concrete	$k_{c,cr}$	SI (in-lb)	7.1 (17)							
Effectiveness factor for uncracked concrete	$k_{c,uncr}$	SI (in-lb)	10 (24)							
Strength reduction factor for tension, concrete failure modes, Condition B (supplemental reinforcement not present) <sup>2</sup>	$\phi$	-	0.65							
Strength reduction factor for shear, concrete failure modes, Condition B (supplemental reinforcement not present) <sup>2</sup>	$\phi$	-	0.70							

For SI: 1 inch ≅ 25.4 mm, 1 lbf = 4.448 N, 1 psi = 0.006897 MPa.  
For pound-inch units: 1 mm = 0.03937 inches, 1 N = 0.2248 lbf, 1 MPa = 145.0 psi

<sup>1</sup> Additional setting information is described in Figure 6, Manufacturers Printed Installation Instructions (MPII).

<sup>2</sup> The strength reduction factor applies when the load combinations from the IBC or ACI 318 are used and the requirements of ACI 318-19 17.5.3, ACI 318-14 17.3.3 or ACI 318-11 D.4.3, as applicable, are met. If the load combinations of ACI 318-11 Appendix C are used, the appropriate strength reduction factor must be determined in accordance with ACI 318-11 D.4.4.

<sup>3</sup> For installations with 1<sup>3</sup>/<sub>4</sub>-inch edge distance, refer to Section 4.1.9.2 for spacing and maximum torque requirements.

<sup>4</sup>  $d_o$  = hole diameter.

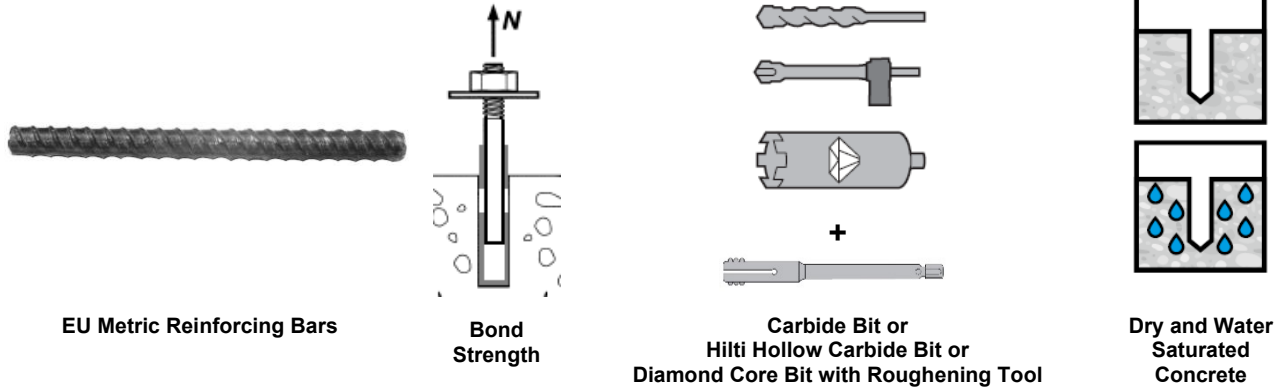

**TABLE 19—BOND STRENGTH DESIGN INFORMATION FOR EU METRIC REINFORCING BARS**

**IN HOLES DRILLED WITH A HAMMER DRILL AND CARBIDE BIT (OR HILTI HOLLOW CARBIDE DRILL BIT) OR CORE DRILLED WITH A DIAMOND CORE BIT AND ROUGHENED WITH A HILTI ROUGHENING TOOL<sup>1</sup>**

DESIGN INFORMATION		Symbol	Units	Reinforcing bar size							
				10	12	14	16	20	25	28	32
Minimum Embedment		$h_{ef,min}$	mm (in.)	60 (2.4)	70 (2.8)	75 (3.0)	80 (3.1)	90 (3.5)	100 (3.9)	112 (4.4)	128 (5.0)
Maximum Embedment		$h_{ef,max}$	mm (in.)	200 (7.9)	240 (9.4)	280 (11.0)	320 (12.6)	400 (15.7)	500 (19.7)	560 (22.0)	640 (25.2)
Temperature range A <sup>2</sup>	Characteristic bond strength in cracked concrete	$\tau_{k,cr}$	MPa (psi)	7.4 (1,075)	7.5 (1,080)	7.5 (1,085)	7.5 (1,090)	7.5 (1,095)	5.8 (840)	5.8 (845)	5.9 (850)
	Characteristic bond strength in uncracked concrete	$\tau_{k,uncr}$	MPa (psi)	10.8 (1,560)	10.8 (1,560)	10.8 (1,560)	10.8 (1,560)	10.8 (1,560)	10.8 (1,560)	10.8 (1,560)	10.8 (1,560)
Temperature range B <sup>2</sup>	Characteristic bond strength in cracked concrete	$\tau_{k,cr}$	MPa (psi)	7.4 (1,075)	7.5 (1,080)	7.5 (1,085)	7.5 (1,090)	7.5 (1,095)	5.8 (840)	5.8 (845)	5.9 (850)
	Characteristic bond strength in uncracked concrete	$\tau_{k,uncr}$	MPa (psi)	10.8 (1,560)	10.8 (1,560)	10.8 (1,560)	10.8 (1,560)	10.8 (1,560)	10.8 (1,560)	10.8 (1,560)	10.8 (1,560)
Temperature range C <sup>2</sup>	Characteristic bond strength in cracked concrete	$\tau_{k,cr}$	MPa (psi)	6.1 (885)	6.1 (885)	6.1 (890)	6.2 (895)	6.2 (900)	4.8 (690)	4.8 (695)	4.8 (700)
	Characteristic bond strength in uncracked concrete	$\tau_{k,uncr}$	MPa (psi)	8.8 (1,280)	8.8 (1,280)	8.8 (1,280)	8.8 (1,280)	8.8 (1,280)	8.8 (1,280)	8.8 (1,280)	8.8 (1,280)
Permissible Installation Conditions	Dry and water saturated concrete	Anchor Category	-	1							
		$\phi_d, \phi_{ws}$	-	0.65							
Reduction for seismic tension	 Hammer drilled	$\alpha_{N,seis}$	-	0.80				0.85	0.90	1.00	
	 Core drilled + roughening	$\alpha_{N,seis}$	-	N/A			0.71	0.77	0.86	0.78	0.86

For SI: 1 inch ≡ 25.4 mm, 1 lbf = 4.448 N, 1 psi = 0.006897 MPa.  
For pound-inch units: 1 mm = 0.03937 inches, 1 N = 0.2248 lbf, 1 MPa = 145.0 psi

<sup>1</sup> Bond strength values correspond to concrete compressive strength  $f'_c = 2,500$  psi (17.2 MPa). For concrete compressive strength,  $f'_c$ , between 2,500 psi (17.2 MPa) and 8,000 psi (55.2 MPa), the tabulated characteristic bond strength may be increased by a factor of  $(f'_c / 2,500)^{0.1}$  [For SI:  $(f'_c / 17.2)^{0.1}$ ]. See Section 4.1.4 of this report for bond strength determination.

<sup>2</sup> Temperature range A: Maximum short term temperature = 130°F (55°C), Maximum long term temperature = 110°F (43°C).  
Temperature range B: Maximum short term temperature = 176°F (80°C), Maximum long term temperature = 110°F (43°C).  
Temperature range C: Maximum short term temperature = 248°F (120°C), Maximum long term temperature = 162°F (72°C).

Short term elevated concrete temperatures are those that occur over brief intervals, e.g., as a result of diurnal cycling. Long term concrete temperatures are roughly constant over significant periods of time.

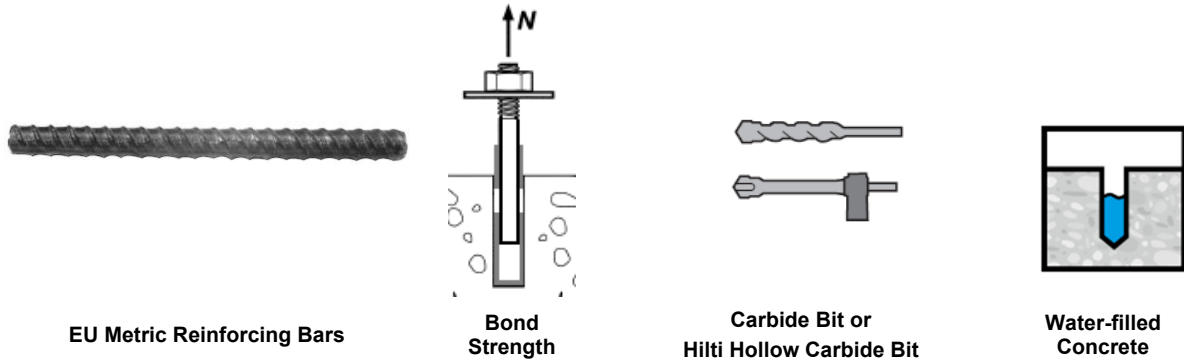

**TABLE 20—BOND STRENGTH DESIGN INFORMATION FOR FRACTIONAL REINFORCING BARS IN HOLES DRILLED WITH A HAMMER DRILL AND CARBIDE BIT (OR HILTI HOLLOW CARBIDE DRILL BIT)**

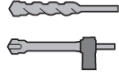
DESIGN INFORMATION		Symbol	Units	Nominal reinforcing bar size							
				10	12	14	16	20	25	28	32
Minimum Embedment		$h_{ef,min}$	in. (mm)	2 <sup>3</sup> / <sub>8</sub> (60)	2 <sup>3</sup> / <sub>4</sub> (70)	3 <sup>1</sup> / <sub>8</sub> (79)	3 <sup>1</sup> / <sub>2</sub> (89)	3 <sup>1</sup> / <sub>2</sub> (89)	4 (102)	4 <sup>1</sup> / <sub>2</sub> (114)	5 (127)
Maximum Embedment		$h_{ef,max}$	in. (mm)	7 <sup>1</sup> / <sub>2</sub> (191)	10 (254)	12 <sup>1</sup> / <sub>2</sub> (318)	15 (381)	17 <sup>1</sup> / <sub>2</sub> (445)	20 (508)	22 <sup>1</sup> / <sub>2</sub> (572)	25 (635)
Temperature range A <sup>2</sup>	Characteristic bond strength in cracked concrete	$\tau_{k,cr}$	MPa (psi)	(7.2) 1,050	(7.2) 1,050	(7.2) 1,050	(7.4) 1,070	(7.4) 1,070	(5.7) 820	(5.7) 820	(5.7) 830
	Characteristic bond strength in uncracked concrete	$\tau_{k,uncr}$	MPa (psi)	(10.5) 1,520	(10.5) 1,520	(10.5) 1,520	(10.5) 1,520	(10.5) 1,520	(10.5) 1,520	(10.5) 1,520	(10.5) 1,520
Temperature range B <sup>2</sup>	Characteristic bond strength in cracked concrete	$\tau_{k,cr}$	MPa (psi)	(7.2) 1,050	(7.2) 1,050	(7.2) 1,050	(7.4) 1,070	(7.4) 1,070	(5.7) 820	(5.7) 820	(5.7) 830
	Characteristic bond strength in uncracked concrete	$\tau_{k,uncr}$	MPa (psi)	(10.5) 1,520	(10.5) 1,520	(10.5) 1,520	(10.5) 1,520	(10.5) 1,520	(10.5) 1,520	(10.5) 1,520	(10.5) 1,520
Temperature range C <sup>2</sup>	Characteristic bond strength in cracked concrete	$\tau_{k,cr}$	MPa (psi)	(6.0) 865	(6.0) 865	(6.0) 865	(6.1) 875	(6.1) 875	(4.7) 680	(4.7) 680	(4.7) 680
	Characteristic bond strength in uncracked concrete	$\tau_{k,uncr}$	MPa (psi)	(8.6) 1,250	(8.6) 1,250	(8.6) 1,250	(8.6) 1,250	(8.6) 1,250	(8.6) 1,250	(8.6) 1,250	(8.6) 1,250
Permissible installation conditions	Water-filled Hole 	Anchor Category	-	3							
		$\phi_{wf}$	-	0.45							
Reduction for seismic tension	Hammer drilled 	$\alpha_{N,seis}$	-	0.80			0.85	0.90	0.95	1.0	

For SI: 1 inch ≅ 25.4 mm, 1 lbf = 4.448 N, 1 psi = 0.006897 MPa.

For pound-inch units: 1 mm = 0.03937 inches, 1 N = 0.2248 lbf, 1 MPa = 145.0 psi

<sup>1</sup> Bond strength values correspond to concrete compressive strength  $f_c = 2,500$  psi (17.2 MPa). For concrete compressive strength,  $f_c$ , between 2,500 psi (17.2 MPa) and 8,000 psi (55.2 MPa), the tabulated characteristic bond strength may be increased by a factor of  $(f_c / 2,500)^{0.1}$  [For SI:  $(f_c / 17.2)^{0.1}$ ]. See Section 4.1.4 of this report for bond strength determination.

<sup>2</sup> Temperature range A: Maximum short term temperature = 130°F (55°C), Maximum long term temperature = 110°F (43°C).  
 Temperature range B: Maximum short term temperature = 176°F (80°C), Maximum long term temperature = 110°F (43°C).  
 Temperature range C: Maximum short term temperature = 248°F (120°C), Maximum long term temperature = 162°F (72°C).

Short term elevated concrete temperatures are those that occur over brief intervals, e.g., as a result of diurnal cycling. Long term concrete temperatures are roughly constant over significant periods of time.

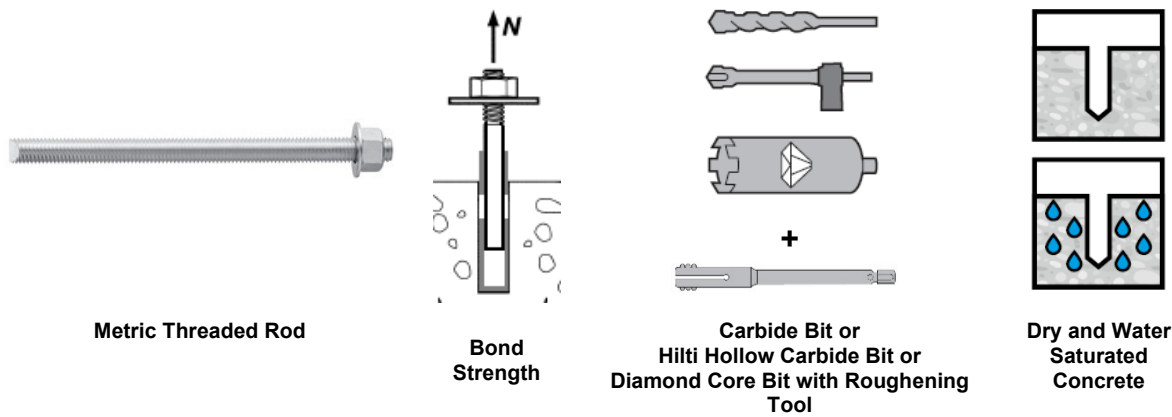

**TABLE 21—BOND STRENGTH DESIGN INFORMATION FOR METRIC THREADED ROD**

**IN HOLES DRILLED WITH A HAMMER DRILL AND CARBIDE BIT (OR HILTI HOLLOW CARBIDE DRILL BIT) OR CORE DRILLED WITH A DIAMOND CORE BIT AND ROUGHENED WITH A HILTI ROUGHENING TOOL<sup>1</sup>**

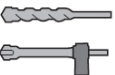
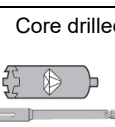
DESIGN INFORMATION		Symbol	Units	Nominal rod diameter (mm)						
				10	12	16	20	24	27	30
Minimum Embedment		$h_{ef,min}$	mm (in.)	60 (2.4)	70 (2.8)	80 (3.1)	90 (3.5)	96 (3.8)	108 (4.3)	120 (4.7)
Maximum Embedment		$h_{ef,max}$	mm (in.)	200 (7.9)	240 (9.4)	320 (12.6)	400 (15.7)	480 (18.9)	540 (21.3)	600 (23.6)
Temperature range A <sup>2</sup>	Characteristic bond strength in cracked concrete	$\tau_{k,cr}$	MPa (psi)	7.3 (1,055)	7.6 (1,105)	8.1 (1,170)	8.8 (1,270)	9.0 (1,305)	9.2 (1,340)	9.4 (1,365)
	Characteristic bond strength in uncracked concrete	$\tau_{k,uncr}$	MPa (psi)	15.3 (2,220)	15.3 (2,220)	15.3 (2,220)	15.3 (2,220)	15.3 (2,220)	15.3 (2,220)	15.3 (2,220)
Temperature range B <sup>2</sup>	Characteristic bond strength in cracked concrete	$\tau_{k,cr}$	MPa (psi)	7.3 (1,055)	7.6 (1,105)	8.1 (1,170)	8.8 (1,270)	9.0 (1,305)	9.2 (1,340)	9.4 (1,365)
	Characteristic bond strength in uncracked concrete	$\tau_{k,uncr}$	MPa (psi)	15.3 (2,220)	15.3 (2,220)	15.3 (2,220)	15.3 (2,220)	15.3 (2,220)	15.3 (2,220)	15.3 (2,220)
Temperature range C <sup>2</sup>	Characteristic bond strength in cracked concrete	$\tau_{k,cr}$	MPa (psi)	6.0 (865)	6.3 (905)	6.6 (960)	7.2 (1,040)	7.4 (1,070)	7.6 (1,095)	7.7 (1,120)
	Characteristic bond strength in uncracked concrete	$\tau_{k,uncr}$	MPa (psi)	12.6 (1,820)	12.6 (1,820)	12.6 (1,820)	12.6 (1,820)	12.6 (1,820)	12.6 (1,820)	12.6 (1,820)
Permissible Installation Conditions	Dry and water saturated concrete	Anchor Category	-	1						
		$\phi_a, \phi_{ws}$	-	0.65						
Reduction for seismic tension	 Hammer drilled	$\alpha_{N,seis}$	-	0.88	0.88	0.99	1.0	0.95	0.95	0.95
	 Core drilled + roughening	$\alpha_{N,seis}$	-	N/A		0.88	0.96	0.96	0.82	0.82

For SI: 1 inch  $\equiv$  25.4 mm, 1 lbf = 4.448 N, 1 psi = 0.006897 MPa.  
For pound-inch units: 1 mm = 0.03937 inches, 1 N = 0.2248 lbf, 1 MPa = 145.0 psi

<sup>1</sup> Bond strength values correspond to concrete compressive strength  $f_c = 2,500$  psi (17.2 MPa). For concrete compressive strength,  $f_c$ , between 2,500 psi (17.2 MPa) and 8,000 psi (55.2 MPa), the tabulated characteristic bond strength may be increased by a factor of  $(f_c / 2,500)^{0.1}$  [For SI:  $(f_c / 17.2)^{0.1}$ ]. See Section 4.1.4 of this report for bond strength determination.

<sup>2</sup> Temperature range A: Maximum short term temperature = 130°F (55°C), Maximum long term temperature = 110°F (43°C).  
Temperature range B: Maximum short term temperature = 176°F (80°C), Maximum long term temperature = 110°F (43°C).  
Temperature range C: Maximum short term temperature = 248°F (120°C), Maximum long term temperature = 162°F (72°C).  
Short term elevated concrete temperatures are those that occur over brief intervals, e.g., as a result of diurnal cycling. Long term concrete temperatures are roughly constant over significant periods of time.

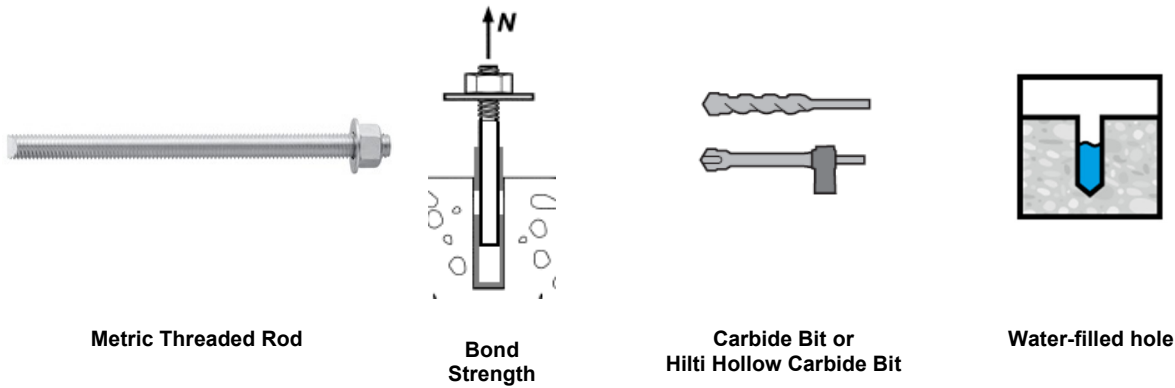

Metric Threaded Rod

Bond Strength

Carbide Bit or Hilti Hollow Carbide Bit

Water-filled hole

TABLE 22—BOND STRENGTH DESIGN INFORMATION FOR METRIC THREADED ROD IN HOLES DRILLED WITH A HAMMER DRILL AND CARBIDE BIT (OR HILTI HOLLOW CARBIDE DRILL BIT)

DESIGN INFORMATION		Symbol	Units	Nominal rod diameter (mm)						
				10	12	16	20	24	27	30
Minimum Embedment		$h_{ef,min}$	mm (in.)	60 (2.4)	70 (2.8)	80 (3.1)	90 (3.5)	96 (3.8)	108 (4.3)	120 (4.7)
Maximum Embedment		$h_{ef,max}$	mm (in.)	200 (7.9)	240 (9.4)	320 (12.6)	400 (15.7)	480 (18.9)	540 (21.3)	600 (23.6)
Temperature range A <sup>2</sup>	Characteristic bond strength in cracked concrete	$\tau_{k,cr}$	MPa (psi)	5.8 (835)	5.9 (850)	6.0 (865)	6.2 (900)	6.1 (885)	6.0 (870)	5.9 (860)
	Characteristic bond strength in uncracked concrete	$\tau_{k,uncr}$	MPa (psi)	12.1 (1755)	11.8 (1710)	11.3 (1645)	10.9 (1580)	10.4 (1510)	10.0 (1445)	9.7 (1400)
Temperature range B <sup>2</sup>	Characteristic bond strength in cracked concrete	$\tau_{k,cr}$	MPa (psi)	5.8 (835)	5.9 (850)	6.0 (865)	6.2 (900)	6.1 (885)	6.0 (870)	5.9 (860)
	Characteristic bond strength in uncracked concrete	$\tau_{k,uncr}$	MPa (psi)	12.1 (1755)	11.8 (1710)	11.3 (1645)	10.9 (1580)	10.4 (1510)	10.0 (1445)	9.7 (1400)
Temperature range C <sup>2</sup>	Characteristic bond strength in cracked concrete	$\tau_{k,cr}$	MPa (psi)	4.7 (685)	4.8 (700)	4.9 (710)	5.1 (740)	5.0 (725)	4.9 (715)	4.9 (705)
	Characteristic bond strength in uncracked concrete	$\tau_{k,uncr}$	MPa (psi)	9.9 (1440)	9.7 (1405)	9.3 (1350)	8.9 (1295)	8.5 (1240)	8.2 (1185)	7.9 (1150)
Permissible Installation Conditions	Water-filled hole 	Anchor Category	-	3						
		$\phi_{wf}$	-	0.45						
Reduction for seismic tension	 Hammer drilled	$\alpha_{N,seis}$	-	0.88	0.88	0.99	1.0	0.95	0.95	0.95

For SI: 1 inch  $\equiv$  25.4 mm, 1 lbf = 4.448 N, 1 psi = 0.006897 MPa.

For pound-inch units: 1 mm = 0.03937 inches, 1 N = 0.2248 lbf, 1 MPa = 145.0 psi

<sup>1</sup> Bond strength values correspond to concrete compressive strength  $f'_c = 2,500$  psi (17.2 MPa). For concrete compressive strength,  $f'_c$ , between 2,500 psi (17.2 MPa) and 8,000 psi (55.2 MPa), the tabulated characteristic bond strength may be increased by a factor of  $(f'_c / 2,500)^{0.1}$  [For SI:  $(f'_c / 17.2)^{0.1}$ ]. See Section 4.1.4 of this report for bond strength determination.

<sup>2</sup> Temperature range A: Maximum short-term temperature = 130°F (55°C), Maximum long-term temperature = 110°F (43°C).

Temperature range B: Maximum short-term temperature = 176°F (80°C), Maximum long-term temperature = 110°F (43°C).

Temperature range C: Maximum short-term temperature = 248°F (120°C), Maximum long-term temperature = 162°F (72°C).

short-term elevated concrete temperatures are those that occur over brief intervals, e.g., as a result of diurnal cycling. long-term concrete temperatures are roughly constant over significant periods of time.





Canadian Reinforcing Bars

Steel Strength

TABLE 23—STEEL DESIGN INFORMATION FOR CANADIAN METRIC REINFORCING BARS

DESIGN INFORMATION		Symbol	Units	Bar size				
				10 M	15 M	20 M	25 M	30 M
Nominal bar diameter		$d$	mm (in.)	11.3 (0.445)	16.0 (0.630)	19.5 (0.768)	25.2 (0.992)	29.9 (1.177)
Bar effective cross-sectional area		$A_{se}$	mm <sup>2</sup> (in. <sup>2</sup> )	100.3 (0.155)	201.1 (0.312)	298.6 (0.463)	498.8 (0.773)	702.2 (1.088)
CSA G30	Nominal strength as governed by steel strength	$N_{sa}$	kN (lb)	54.0 (12,175)	108.5 (24,408)	161.5 (36,255)	270.0 (60,548)	380.0 (85,239)
		$V_{sa}$	kN (lb)	32.5 (7,305)	65.0 (14,645)	97.0 (21,753)	161.5 (36,329)	227.5 (51,144)
	Reduction for seismic shear	$\alpha_{V,seis}$	-	0.70				
	Strength reduction factor for tension <sup>1</sup>	$\phi$	-	0.65				
	Strength reduction factor for shear <sup>1</sup>	$\phi$	-	0.60				

For SI: 1 inch ≡ 25.4 mm, 1 lbf = 4.448 N, 1 psi = 0.006897 MPa.

For pound-inch units: 1 mm = 0.03937 inches, 1 N = 0.2248 lbf, 1 MPa = 145.0 psi

<sup>1</sup> For use with the load combinations of ACI 318-19 and ACI 318-14 5.3 or ACI 318-11 9.2, as set forth in ACI 318-19 17.5.3, ACI 318-14 17.3.3 or ACI 318-11 D.4.3. Values correspond to a brittle steel element.

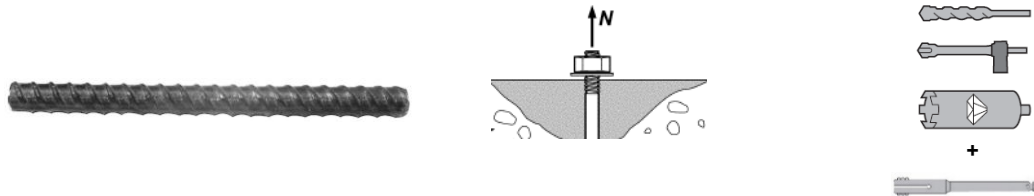

Canadian Reinforcing Bars

Concrete Breakout Strength

Carbide Bit or Hilti Hollow Carbide Bit or Diamond Core Bit with Roughening Tool

TABLE 24—CONCRETE BREAKOUT DESIGN INFORMATION FOR CANADIAN METRIC REINFORCING BARS IN HOLES DRILLED WITH A HAMMER DRILL AND CARBIDE BIT (OR HILTI HOLLOW CARBIDE DRILL BIT) OR CORE DRILLED WITH A DIAMOND CORE BIT AND ROUGHENED WITH A HILTI ROUGHENING TOOL<sup>1</sup>

DESIGN INFORMATION		Symbol	Units	Bar size				
				10 M	15 M	20 M	25 M	30 M
Effectiveness factor for cracked concrete		$k_{c,cr}$	SI (in-lb)	7.1 (17)				
Effectiveness factor for uncracked concrete		$k_{c,uncr}$	SI (in-lb)	10 (24)				
Minimum Embedment		$h_{ef,min}$	mm (in.)	70 (2.8)	80 (3.1)	90 (3.5)	101 (4.0)	120 (4.7)
Maximum Embedment		$h_{ef,max}$	mm (in.)	226 (8.9)	320 (12.6)	390 (15.4)	504 (19.8)	598 (23.5)
Min. bar spacing <sup>3</sup>		$s_{min}$	mm (in.)	57 (2.2)	80 (3.1)	98 (3.8)	126 (5.0)	150 (5.9)
Min. edge distance <sup>3</sup>		$c_{min}$	mm (in.)	5d; or see Section 4.1.9.2 of this report for design with reduced minimum edge distances				
Minimum concrete thickness		$h_{min}$	mm (in.)	$h_{ef} + 30$ ( $h_{ef} + 1\frac{1}{4}$ )	$h_{ef} + 2d_o^{(4)}$			
Critical edge distance – splitting (for uncracked concrete)		$c_{cac}$	-	See Section 4.1.10.2 of this report.				
Strength reduction factor for tension, concrete failure modes, Condition B (supplemental reinforcement not present) <sup>2</sup>		$\phi$	-	0.65				
Strength reduction factor for shear, concrete failure modes, Condition B (supplemental reinforcement not present) <sup>2</sup>		$\phi$	-	0.70				

For SI: 1 inch ≡ 25.4 mm, 1 lbf = 4.448 N, 1 psi = 0.006897 MPa.

For pound-inch units: 1 mm = 0.03937 inches, 1 N = 0.2248 lbf, 1 MPa = 145.0 psi

<sup>1</sup> Additional setting information is described in Figure 6, Manufacturers Printed Installation Instructions (MPII).

<sup>2</sup> The strength reduction factor applies when the load combinations from the IBC or ACI 318 are used and the requirements of ACI 318-19 17.5.3, ACI 318-14 17.3.3 or ACI 318-11 D.4.3, as applicable, are met. If the load combinations of ACI 318-11 Appendix C are used, the appropriate strength reduction factor must be determined in accordance with ACI 318-11 D.4.4.

<sup>3</sup> For installations with 1<sup>3</sup>/<sub>4</sub>-inch edge distance, refer to Section 4.1.9.2 for spacing and maximum torque requirements.

<sup>4</sup>  $d_0$  = hole diameter.

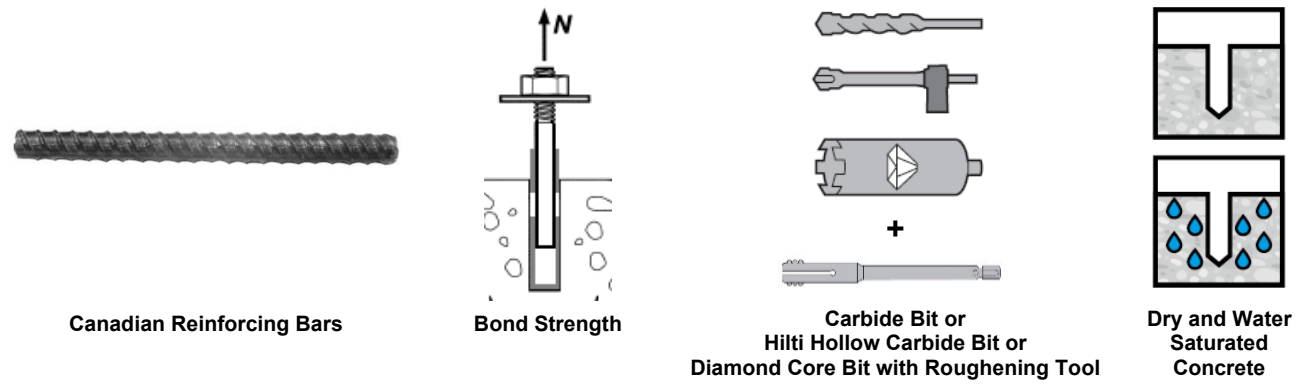

**TABLE 25—BOND STRENGTH DESIGN INFORMATION FOR CANADIAN METRIC REINFORCING BARS IN HOLES DRILLED WITH A HAMMER DRILL AND CARBIDE BIT (OR HILTI HOLLOW CARBIDE DRILL BIT) OR CORE DRILLED WITH A DIAMOND CORE BIT AND ROUGHENED WITH A HILTI ROUGHENING TOOL<sup>1</sup>**

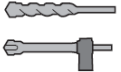
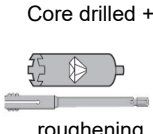
DESIGN INFORMATION		Symbol	Units	Bar size				
				10 M	15 M	20 M	25 M	30 M
Minimum Embedment		$h_{ef,min}$	mm (in.)	70 (2.8)	80 (3.1)	90 (3.5)	101 (4.0)	120 (4.7)
Maximum Embedment		$h_{ef,max}$	mm (in.)	226 (8.9)	320 (12.6)	390 (15.4)	504 (19.8)	598 (23.5)
Temperature range A <sup>2</sup>	Characteristic bond strength in cracked concrete	$\tau_{k,cr}$	MPa (psi)	7.4 (1,075)	7.5 (1,085)	7.5 (1,095)	5.8 (840)	5.9 (850)
	Characteristic bond strength in uncracked concrete	$\tau_{k,uncr}$	MPa (psi)	10.8 (1,560)	10.8 (1,560)	10.8 (1,560)	10.8 (1,560)	10.8 (1,560)
Temperature range B <sup>2</sup>	Characteristic bond strength in cracked concrete	$\tau_{k,cr}$	MPa (psi)	7.4 (1,075)	7.5 (1,085)	7.5 (1,095)	5.8 (840)	5.9 (850)
	Characteristic bond strength in uncracked concrete	$\tau_{k,uncr}$	MPa (psi)	10.8 (1,560)	10.8 (1,560)	10.8 (1,560)	10.8 (1,560)	10.8 (1,560)
Temperature range C <sup>2</sup>	Characteristic bond strength in cracked concrete	$\tau_{k,cr}$	MPa (psi)	6.1 (885)	6.2 (895)	6.2 (900)	4.8 (690)	4.8 (700)
	Characteristic bond strength in uncracked concrete	$\tau_{k,uncr}$	MPa (psi)	8.8 (1,280)	8.8 (1,280)	8.8 (1,280)	8.8 (1,280)	8.8 (1,280)
Permissible installation conditions	Dry and water saturated concrete	Anchor Category	-	1				
		$\phi_d, \phi_{ws}$	-	0.65				
Reduction for seismic tension	 Hammer drilled	$\alpha_{N,seis}$	-	0.80		0.85		0.97
	 Core drilled + roughening	$\alpha_{N,seis}$	-	N/A	0.71	0.77	N/A	

For SI: 1 inch = 25.4 mm, 1 lbf = 4.448 N, 1 psi = 0.006897 MPa.  
For pound-inch units: 1 mm = 0.03937 inches, 1 N = 0.2248 lbf, 1 MPa = 145.0 psi

<sup>1</sup> Bond strength values correspond to concrete compressive strength  $f_c = 2,500$  psi (17.2 MPa). For concrete compressive strength,  $f_c$ , between 2,500 psi (17.2 MPa) and 8,000 psi (55.2 MPa), the tabulated characteristic bond strength may be increased by a factor of  $(f_c / 2,500)^{0.1}$  [For SI:  $(f_c / 17.2)^{0.1}$ ]. See Section 4.1.4 of this report for bond strength determination.

<sup>2</sup> Temperature range A: Maximum short term temperature = 130°F (55°C), Maximum long term temperature = 110°F (43°C).  
Temperature range B: Maximum short term temperature = 176°F (80°C), Maximum long term temperature = 110°F (43°C).  
Temperature range C: Maximum short term temperature = 248°F (120°C), Maximum long term temperature = 162°F (72°C).  
Short term elevated concrete temperatures are those that occur over brief intervals, e.g., as a result of diurnal cycling. Long term concrete temperatures are roughly constant over significant periods of time.

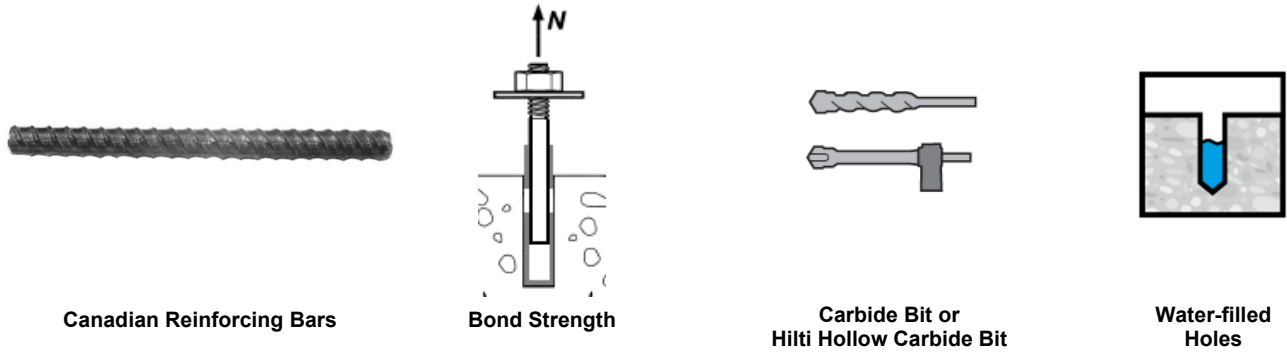

**TABLE 26—BOND STRENGTH DESIGN INFORMATION FOR CANADIAN METRIC REINFORCING BARS IN HOLES DRILLED WITH A HAMMER DRILL AND CARBIDE BIT (OR HILTI HOLLOW CARBIDE DRILL BIT)**

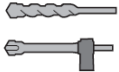
DESIGN INFORMATION		Symbol	Units	Bar size				
				10 M	15 M	20 M	25 M	30 M
Minimum Embedment		$h_{ef,min}$	mm (in.)	70 (2.8)	80 (3.1)	90 (3.5)	101 (4.0)	120 (4.7)
Maximum Embedment		$h_{ef,max}$	mm (in.)	226 (8.9)	320 (12.6)	390 (15.4)	504 (19.8)	598 (23.5)
Temperature range A <sup>2</sup>	Characteristic bond strength in cracked concrete	$\tau_{k,cr}$	MPa (psi)	7.3 (1,050)	7.4 (1,070)	7.4 (1,070)	5.7 (820)	5.8 (830)
	Characteristic bond strength in uncracked concrete	$\tau_{k,uncr}$	MPa (psi)	10.5 (1,520)	10.5 (1,520)	10.5 (1,520)	10.5 (1,520)	10.5 (1,520)
Temperature range B <sup>2</sup>	Characteristic bond strength in cracked concrete	$\tau_{k,cr}$	MPa (psi)	7.3 (1,050)	7.4 (1,070)	7.4 (1,070)	5.7 (820)	5.8 (830)
	Characteristic bond strength in uncracked concrete	$\tau_{k,uncr}$	MPa (psi)	10.5 (1,520)	10.5 (1,520)	10.5 (1,520)	10.5 (1,520)	10.5 (1,520)
Temperature range C <sup>2</sup>	Characteristic bond strength in cracked concrete	$\tau_{k,cr}$	MPa (psi)	6.0 (865)	6.1 (875)	6.1 (875)	4.7 (680)	6.0 (865)
	Characteristic bond strength in uncracked concrete	$\tau_{k,uncr}$	MPa (psi)	8.6 (1,250)	8.6 (1,250)	8.6 (1,250)	8.6 (1,250)	8.6 (1,250)
Permissible installation conditions	Water-filled Holes 	Anchor Category	-	3				
		$\phi_{wt}$	-	0.45				
Reduction for seismic tension	 Hammer drilled	$\alpha_{N,seis}$	-	0.80			0.85	0.97

For SI: 1 inch = 25.4 mm, 1 lbf = 4.448 N, 1 psi = 0.006897 MPa.  
For pound-inch units: 1 mm = 0.03937 inches, 1 N = 0.2248 lbf, 1 MPa = 145.0 psi

<sup>1</sup> Bond strength values correspond to concrete compressive strength  $f'_c = 2,500$  psi (17.2 MPa). For concrete compressive strength,  $f'_c$ , between 2,500 psi (17.2 MPa) and 8,000 psi (55.2 MPa), the tabulated characteristic bond strength may be increased by a factor of  $(f'_c / 2,500)^{0.1}$  [For SI:  $(f'_c / 17.2)^{0.1}$ ]. See Section 4.1.4 of this report for bond strength determination.

<sup>2</sup> Temperature range A: Maximum short term temperature = 130°F (55°C), Maximum long term temperature = 110°F (43°C).  
Temperature range B: Maximum short term temperature = 176°F (80°C), Maximum long term temperature = 110°F (43°C).  
Temperature range C: Maximum short term temperature = 248°F (120°C), Maximum long term temperature = 162°F (72°C).  
Short term elevated concrete temperatures are those that occur over brief intervals, e.g., as a result of diurnal cycling. Long term concrete temperatures are roughly constant over significant periods of time.



Fractional and Metric HIS-N and HIS-RN Internal Threaded Insert

Steel Strength

TABLE 27—STEEL DESIGN INFORMATION FOR FRACTIONAL AND METRIC HIS-N AND HIS-RN THREADED INSERTS<sup>1</sup>

DESIGN INFORMATION	Symbol	Units	Nominal Bolt/Cap Screw Diameter (in.) Fractional				Units	Nominal Bolt/Cap Screw Diameter (mm) Metric					
			<sup>3</sup> / <sub>8</sub>	<sup>1</sup> / <sub>2</sub>	<sup>5</sup> / <sub>8</sub>	<sup>3</sup> / <sub>4</sub>		8	10	12	16	20	
HIS Insert O.D.	<i>D</i>	in. (mm)	0.65 (16.5)	0.81 (20.5)	1.00 (25.4)	1.09 (27.6)	mm (in.)	12.5 (0.49)	16.5 (0.65)	20.5 (0.81)	25.4 (1.00)	27.6 (1.09)	
HIS insert length	<i>L</i>	in. (mm)	4.33 (110)	4.92 (125)	6.69 (170)	8.07 (205)	mm (in.)	90 (3.54)	110 (4.33)	125 (4.92)	170 (6.69)	205 (8.07)	
Bolt effective cross-sectional area	<i>A<sub>se</sub></i>	in. <sup>2</sup> (mm <sup>2</sup> )	0.0775 (50)	0.1419 (92)	0.2260 (146)	0.3345 (216)	mm <sup>2</sup> (in. <sup>2</sup> )	36.6 (0.057)	58 (0.090)	84.3 (0.131)	157 (0.243)	245 (0.380)	
HIS insert effective cross-sectional area	<i>A<sub>insert</sub></i>	in. <sup>2</sup> (mm <sup>2</sup> )	0.178 (115)	0.243 (157)	0.404 (260)	0.410 (265)	mm <sup>2</sup> (in. <sup>2</sup> )	51.5 (0.080)	108 (0.167)	169.1 (0.262)	256.1 (0.397)	237.6 (0.368)	
ASTM A193 B7	Nominal steel strength – ASTM A193 B7 <sup>3</sup> bolt/cap screw	<i>N<sub>sa</sub></i>	lb (kN)	9,690 (43.1)	17,740 (78.9)	28,250 (125.7)	41,815 (186.0)	kN (lb)	-	-	-	-	-
		<i>V<sub>sa</sub></i>	lb (kN)	5,815 (25.9)	10,645 (47.3)	16,950 (75.4)	25,090 (111.6)	kN (lb)	-	-	-	-	-
	Nominal steel strength – HIS-N insert	<i>N<sub>sa</sub></i>	lb (kN)	12,650 (56.3)	16,195 (72.0)	26,925 (119.8)	27,360 (121.7)	kN (lb)	-	-	-	-	-
ASTM A193 Grade B8M SS	Nominal steel strength – ASTM A193 Grade B8M SS bolt/cap screw	<i>N<sub>sa</sub></i>	lb (kN)	8,525 (37.9)	15,610 (69.4)	24,860 (110.6)	36,795 (163.7)	kN (lb)	-	-	-	-	-
		<i>V<sub>sa</sub></i>	lb (kN)	5,115 (22.8)	9,365 (41.7)	14,915 (66.3)	22,075 (98.2)	kN (lb)	-	-	-	-	-
	Nominal steel strength – HIS-RN insert	<i>N<sub>sa</sub></i>	lb (kN)	17,165 (76.3)	23,430 (104.2)	38,955 (173.3)	39,535 (175.9)	kN (lb)	-	-	-	-	-
ISO 898-1 Class 8.8	Nominal steel strength – ISO 898-1 Class 8.8 bolt/cap screw	<i>N<sub>sa</sub></i>	lb (kN)	-	-	-	-	kN (lb)	29.5 (6,582)	46.5 (10,431)	67.5 (15,161)	125.5 (28,236)	196.0 (44,063)
		<i>V<sub>sa</sub></i>	lb (kN)	-	-	-	-	kN (lb)	17.5 (3,949)	28.0 (6,259)	40.5 (9,097)	75.5 (16,942)	117.5 (26,438)
	Nominal steel strength – HIS-N insert	<i>N<sub>sa</sub></i>	lb (kN)	-	-	-	-	kN (lb)	25.0 (5,669)	53.0 (11,894)	78.0 (17,488)	118.0 (26,483)	110.0 (24,573)
ISO 3506-1 Class A4-70 Stainless	Nominal steel strength – ISO 3506-1 Class A4-70 Stainless bolt/cap screw	<i>N<sub>sa</sub></i>	lb (kN)	-	-	-	-	kN (lb)	25.5 (5,760)	40.5 (9,127)	59.0 (13,266)	110.0 (24,706)	171.5 (38,555)
		<i>V<sub>sa</sub></i>	lb (kN)	-	-	-	-	kN (lb)	15.5 (3,456)	24.5 (5,476)	35.5 (7,960)	66.0 (14,824)	103.0 (23,133)
	Nominal steel strength – HIS-RN insert	<i>N<sub>sa</sub></i>	lb (kN)	-	-	-	-	kN (lb)	36.0 (8,099)	75.5 (16,991)	118.5 (26,612)	179.5 (40,300)	166.5 (37,394)
Reduction for seismic shear	<i>α<sub>V,seis</sub></i>	-	0.94				-	0.94					
Strength reduction factor for tension <sup>2</sup>	<i>φ</i>	-	0.65				-	0.65					
Strength reduction factor for shear <sup>2</sup>	<i>φ</i>	-	0.60				-	0.60					

For SI: 1 inch ≅ 25.4 mm, 1 lbf = 4.448 N, 1 psi = 0.006897MPa.  
For pound-inch units: 1 mm = 0.03937 inches, 1 N = 0.2248 lbf, 1 MPa = 145.0 psi

<sup>1</sup> Values provided for common rod material types based on specified strengths and calculated in accordance with ACI 318-19 Eq. (17.6.1.2), ACI 318-14 Eq. (17.4.1.2), ACI 318-11 Eq. (D-2) and Eq. (D-29). Nuts and washers must be appropriate for the rod.  
<sup>2</sup> The strength reduction factor applies when the load combinations from the IBC or ACI 318 are used and the requirements of ACI 318-19 17.5.3, ACI 318-14 17.3.3 or ACI 318-11 D.4.3, as applicable, are met. If the load combinations of ACI 318-11 Appendix C are used, the appropriate strength reduction factor must be determined in accordance with ACI 318-11 D.4.4.  
<sup>3</sup> For the calculation of the design steel strength in tension and shear for the bolt or screw, the *φ* factor for ductile steel failure according to ACI 318-19 17.5.3, ACI 318-14 17.3.3 or ACI 318-11 D.4.3 can be used.

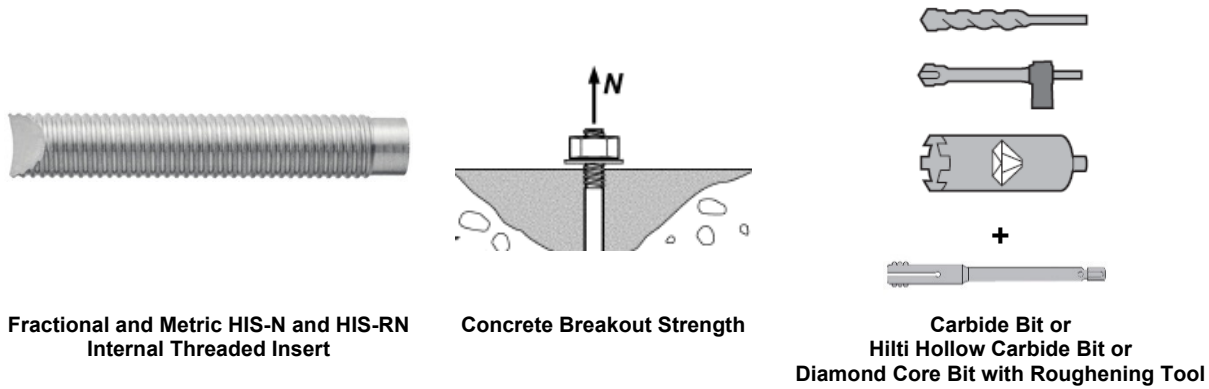
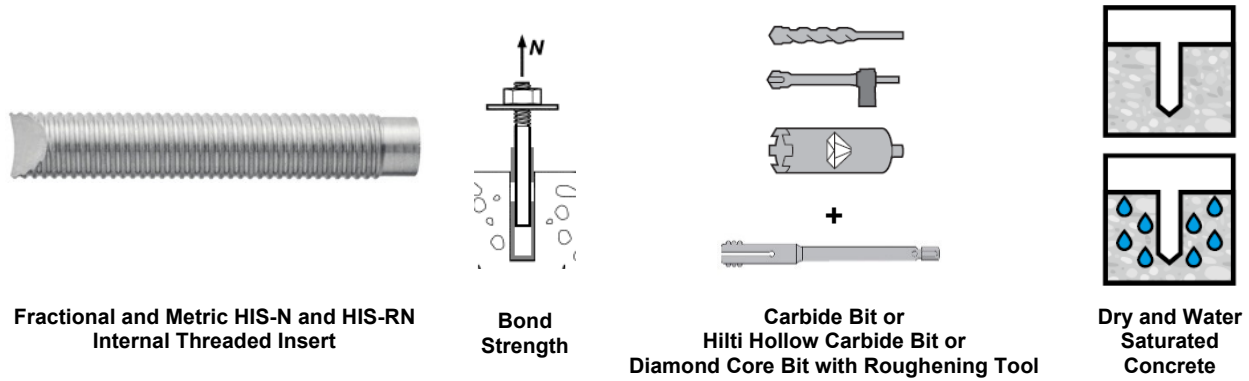

**TABLE 28—CONCRETE BREAKOUT DESIGN INFORMATION FOR FRACTIONAL AND METRIC HILTI HIS-N AND HIS-RN INSERTS IN HOLES DRILLED WITH A HAMMER DRILL AND CARBIDE BIT (OR HILTI HOLLOW CARBIDE DRILL BIT) OR CORE DRILLED WITH A DIAMOND CORE BIT AND ROUGHENED WITH A HILTI ROUGHENING TOOL<sup>1</sup>**

DESIGN INFORMATION	Symbol	Units	Nominal Bolt/Cap Screw Diameter (in.) Fractional				Units	Nominal Bolt/Cap Screw Diameter (mm) Metric				
			3/8	1/2	5/8	3/4		8	10	12	16	20
Effectiveness factor for cracked concrete	$k_{c,cr}$	in-lb (SI)	17 (7.1)				SI (in-lb)	7.1 (17)				
Effectiveness factor for uncracked concrete	$k_{c,un-cr}$	in-lb (SI)	24 (10)				SI (in-lb)	10 (24)				
Effective embedment depth	$h_{ef}$	in. (mm)	4 <sup>3/8</sup> (110)	5 (125)	6 <sup>3/4</sup> (170)	8 <sup>1/8</sup> (205)	mm (in.)	90 (3.5)	110 (4.3)	125 (4.9)	170 (6.7)	205 (8.1)
Min. anchor spacing <sup>3</sup>	$s_{min}$	in. (mm)	3 <sup>1/4</sup> (83)	4 (102)	5 (127)	5 <sup>1/2</sup> (140)	mm (in.)	63 (2.5)	83 (3.25)	102 (4.0)	127 (5.0)	140 (5.5)
Min. edge distance <sup>3</sup>	$c_{min}$	in. (mm)	3 <sup>1/4</sup> (83)	4 (102)	5 (127)	5 <sup>1/2</sup> (140)	mm (in.)	63 (2.5)	83 (3.25)	102 (4.0)	127 (5.0)	140 (5.5)
Minimum concrete thickness	$h_{min}$	in. (mm)	5.9 (150)	6.7 (170)	9.1 (230)	10.6 (270)	mm (in.)	120 (4.7)	150 (5.9)	170 (6.7)	230 (9.1)	270 (10.6)
Critical edge distance – splitting (for uncracked concrete)	$c_{ac}$	-	See Section 4.1.10.2 of this report				-	See Section 4.1.10.2 of this report				
Strength reduction factor for tension, concrete failure modes, Condition B (supplemental reinforcement not present) <sup>2</sup>	$\phi$	-	0.65				-	0.65				
Strength reduction factor for shear, concrete failure modes, Condition B (supplemental reinforcement not present) <sup>2</sup>	$\phi$	-	0.70				-	0.70				

For SI: 1 inch = 25.4 mm, 1 lbf = 4.448 N, 1 psi = 0.006897MPa.  
For pound-inch units: 1 mm = 0.03937 inches, 1 N = 0.2248 lbf, 1 MPa = 145.0 psi

<sup>1</sup> Additional setting information is described in Figure 6, Manufacturers Printed Installation Instructions (MPII).  
<sup>2</sup> The strength reduction factor applies when the load combinations from the IBC or ACI 318 are used and the requirements of ACI 318-19 17.5.3, ACI 318-14 17.3.3 or ACI 318-11 D.4.3, as applicable, are met. If the load combinations of ACI 318-11 Appendix C are used, the appropriate strength reduction factor must be determined in accordance with ACI 318-11 D.4.4.  
<sup>3</sup> For installations with 1<sup>3/4</sup>-inch edge distance, refer to Section 4.1.9.2 for spacing and maximum torque requirements.



Fractional and Metric HIS-N and HIS-RN Internal Threaded Insert

Bond Strength

Carbide Bit or Hilti Hollow Carbide Bit or Diamond Core Bit with Roughening Tool

Dry and Water Saturated Concrete

TABLE 29—BOND STRENGTH DESIGN INFORMATION FOR FRACTIONAL AND METRIC HILTI HIS-N AND HIS-RN INSERTS IN HOLES DRILLED WITH A HAMMER DRILL AND CARBIDE BIT (OR HILTI HOLLOW CARBIDE DRILL BIT)<sup>1</sup>

DESIGN INFORMATION	Symbol	Units	Nominal Bolt/Cap Screw Diameter (in.) Fractional				Units	Nominal Bolt/Cap Screw Diameter (mm) Metric					
			<sup>3</sup> / <sub>8</sub>	<sup>1</sup> / <sub>2</sub>	<sup>5</sup> / <sub>8</sub>	<sup>3</sup> / <sub>4</sub>		8	10	12	16	20	
Effective embedment depth	$h_{ef}$	in. (mm)	4 <sup>3</sup> / <sub>8</sub> (110)	5 (125)	6 <sup>3</sup> / <sub>4</sub> (170)	8 <sup>1</sup> / <sub>8</sub> (205)	mm (in.)	90 (3.5)	110 (4.3)	125 (4.9)	170 (6.7)	205 (8.1)	
HIS Insert O.D.	$D$	in. (mm)	0.65 (16.5)	0.81 (20.5)	1.00 (25.4)	1.09 (27.6)	mm (in.)	12.5 (0.49)	16.5 (0.65)	20.5 (0.81)	25.4 (1.00)	27.6 (1.09)	
Temperature range A <sup>2</sup>	Characteristic bond strength in cracked concrete	$\tau_{k,cr}$	psi (MPa)	870 (6.0)	890 (6.1)	910 (6.3)	920 (6.3)	MPa (psi)	5.9 (850)	6.0 (870)	6.1 (890)	6.3 (910)	6.3 (920)
	Characteristic bond strength in uncracked concrete	$\tau_{k,uncr}$	psi (MPa)	1,950 (13.5)	1,950 (13.5)	1,950 (13.5)	1,950 (13.5)	MPa (psi)	13.5 (1,950)	13.5 (1,950)	13.5 (1,950)	13.5 (1,950)	13.5 (1,950)
Temperature range B <sup>2</sup>	Characteristic bond strength in cracked concrete	$\tau_{k,cr}$	psi (MPa)	870 (6.0)	890 (6.1)	910 (6.3)	920 (6.3)	MPa (psi)	5.9 (850)	6.0 (870)	6.1 (890)	6.3 (910)	6.3 (920)
	Characteristic bond strength in uncracked concrete	$\tau_{k,uncr}$	psi (MPa)	1,950 (13.5)	1,950 (13.5)	1,950 (13.5)	1,950 (13.5)	MPa (psi)	13.5 (1,950)	13.5 (1,950)	13.5 (1,950)	13.5 (1,950)	13.5 (1,950)
Temperature range C <sup>2</sup>	Characteristic bond strength in cracked concrete	$\tau_{k,cr}$	psi (MPa)	715 (4.9)	730 (5.0)	750 (5.2)	755 (5.2)	MPa (psi)	4.8 (695)	4.9 (715)	5.0 (730)	5.2 (750)	5.2 (755)
	Characteristic bond strength in uncracked concrete	$\tau_{k,uncr}$	psi (MPa)	1,600 (11.0)	1,600 (11.0)	1,600 (11.0)	1,600 (11.0)	MPa (psi)	11.0 (1,600)	11.0 (1,600)	11.0 (1,600)	11.0 (1,600)	11.0 (1,600)
Permissible installation conditions	Dry and water saturated conc.	Anchor Category	-	1				-	1				
		$\phi_d, \phi_{ws}$	-	0.65				-	0.65				
Reduction for seismic tension	Hammer drilled	$\alpha_{N,seis}$	-	0.92				-	0.92				
	Core drilled + roughening	$\alpha_{N,seis}$	-	0.81	0.88	0.92	0.76	-	N/A	0.81	0.88	0.92	0.76

For SI: 1 inch ≡ 25.4 mm, 1 lbf = 4.448 N, 1 psi = 0.006897 MPa.  
For pound-inch units: 1 mm = 0.03937 inches, 1 N = 0.2248 lbf, 1 MPa = 145.0 psi

<sup>1</sup> Bond strength values correspond to concrete compressive strength  $f_c = 2,500$  psi (17.2 MPa). For concrete compressive strength,  $f_c$ , between 2,500 psi (17.2 MPa) and 8,000 psi (55.2 MPa), the tabulated characteristic bond strength may be increased by a factor of  $(f_c / 2,500)^{0.1}$  for uncracked concrete,  $[(f_c / 17.2)^{0.1}]$  and  $(f_c / 2,500)^{0.3}$  for cracked concrete, [For SI:  $(f_c / 17.2)^{0.3}$ ]. See Section 4.1.4 of this report for bond strength determination.

<sup>2</sup> Temperature range A: Maximum short term temperature = 130°F (55°C), Maximum long term temperature = 110°F (43°C).  
Temperature range B: Maximum short term temperature = 176°F (80°C), Maximum long term temperature = 110°F (43°C).

Temperature range C: Maximum short term temperature = 248°F (120°C), Maximum long term temperature = 162°F (72°C). Short term elevated concrete temperatures are those that occur over brief intervals, e.g., as a result of diurnal cycling. Long term concrete temperatures are roughly constant over significant periods of time.



HILTI HIT-HY 200 V3 FOIL PACK AND MIXING NOZZLE

HILTI DISPENSER

HILTI TE-CD OR TE-YD HOLLOW CARBIDE DRILL BIT

ANCHORING ELEMENTS

HILTI TE-YRT ROUGHENING TOOL

FIGURE 5—HILTI HIT-HY 200 V3 ANCHORING SYSTEM

TABLE 30—DEVELOPMENT LENGTH FOR U.S. CUSTOMARY UNIT REINFORCING BARS IN HOLES DRILLED WITH A HAMMER DRILL AND CARBIDE BIT OR HILTI HOLLOW CARBIDE BIT<sup>1,2,4</sup>

DESIGN INFORMATION	Symbol	Criteria Section of Reference Standard	Units	Bar size							
				#3	#4	#5	#6	#7	#8	#9	#10
Nominal reinforcing bar diameter	$d_b$	ASTM A615/A706	in. (mm)	0.375 (9.5)	0.500 (12.7)	0.625 (15.9)	0.750 (19.1)	0.875 (22.2)	1.000 (25.4)	1.128 (28.7)	1.270 (32.3)
Nominal bar area	$A_b$	ASTM A615/A706	in <sup>2</sup> (mm <sup>2</sup> )	0.11 (71)	0.20 (129)	0.31 (199)	0.44 (284)	0.60 (387)	0.79 (510)	1.00 (645)	1.27 (819)
Development length for $f_y = 60$ ksi and $f'_c = 2,500$ psi (normal weight concrete) <sup>3</sup>	$l_d$	ACI 318-19 25.4.2.4 ACI 318-14 25.4.2.3 ACI 318-11 12.2.3	in. (mm)	12.0 (304.8)	14.4 (365.8)	18.0 (457.2)	21.6 (548.6)	31.5 (800.1)	36.0 (914.4)	40.6 (1031.4)	45.7 (1161.3)
Development length for $f_y = 60$ ksi and $f'_c = 4,000$ psi (normal weight concrete) <sup>3</sup>	$l_d$	ACI 318-19 25.4.2.4 ACI 318-14 25.4.2.3 ACI 318-11 12.2.3	in. (mm)	12.0 (304.8)	12.0 (304.8)	14.2 (361.4)	17.1 (433.7)	24.9 (632.5)	28.5 (722.9)	32.1 (815.4)	36.1 (918.1)

For SI: 1 inch  $\equiv$  25.4 mm, 1 lbf = 4.448 N, 1 psi = 0.006897 MPa.  
For pound-inch units: 1 mm = 0.03937 inches, 1 N = 0.2248 lbf, 1 MPa = 145.0 psi

<sup>1</sup> Development lengths valid for static, wind, and earthquake loads (SDC A and B).

<sup>2</sup> Development lengths in SDC C through F must comply with ACI 318-19 and ACI 318-14 Chapter 18 or ACI 318-11 Chapter 21 and section 4.2.4 of this report.

<sup>3</sup> For sand-lightweight concrete, increase development length by 33%, unless the provisions of ACI 318-19 25.4.2.5, ACI 318-14 25.4.2.4 or ACI 318-11 12.2.4 (d) are met to permit  $\lambda > 0.75$ .

<sup>4</sup>  $\left( \frac{c_b + K_{tr}}{d_b} \right) = 2.5$ ,  $\psi_t = 1.0$ ,  $\psi_e = 1.0$ ,  $\psi_s = 0.8$  for  $d_b \leq \#6$ , 1.0 for  $d_b > \#6$ .

**TABLE 31—DEVELOPMENT LENGTH FOR EU METRIC REINFORCING BARS IN HOLES DRILLED WITH A HAMMER DRILL AND CARBIDE BIT OR HILTI HOLLOW CARBIDE BIT <sup>1,2,4</sup>**

DESIGN INFORMATION	Symbol	Criteria Section of Reference Standard	Units	Bar size						
				8	10	12	16	20	25	32
Nominal reinforcing bar diameter	$d_b$	BS 4449: 2005	mm (in.)	8 (0.315)	10 (0.394)	12 (0.472)	16 (0.630)	20 (0.787)	25 (0.984)	32 (1.260)
Nominal bar area	$A_b$	BS 4449: 2005	mm <sup>2</sup> (in <sup>2</sup> )	50.3 (0.08)	78.5 (0.12)	113.1 (0.18)	201.1 (0.31)	314.2 (0.49)	490.9 (0.76)	804.2 (1.25)
Development length for $f_y = 72.5$ ksi and $f'_c = 2,500$ psi (normal weight concrete) <sup>3</sup>	$l_d$	ACI 318-19 25.4.2.4 <sup>5</sup> ACI 318-14 25.4.2.3 ACI 318-11 12.2.3	mm (in.)	305 (12.0)	348 (13.7)	417 (16.4)	556 (21.9)	871 (34.3)	1087 (42.8)	1392 (54.8)
Development length for $f_y = 72.5$ ksi and $f'_c = 4,000$ psi (normal weight concrete) <sup>3</sup>	$l_d$	ACI 318-19 25.4.2.4 <sup>5</sup> ACI 318-14 25.4.2.3 ACI 318-11 12.2.3	mm (in.)	305 (12.0)	305 (12.0)	330 (13.0)	439 (17.3)	688 (27.1)	859 (33.8)	1100 (43.3)

For SI: 1 inch  $\equiv$  25.4 mm, 1 lbf = 4.448 N, 1 psi = 0.006897 MPa.  
For pound-inch units: 1 mm = 0.03937 inches, 1 N = 0.2248 lbf, 1 MPa = 145.0 psi

<sup>1</sup>Development lengths valid for static, wind, and earthquake loads (SDC A and B).

<sup>2</sup>Development lengths in SDC C through F must comply with ACI 318-19 and ACI 318-14 Chapter 18 or ACI 318-11 Chapter 21 and section 4.2.4 of this report.

<sup>3</sup>For sand-lightweight concrete, increase development length by 33%, unless the provisions of ACI 318-19 25.4.2.5, ACI 318-14 25.4.2.4 or ACI 318-11 12.2.4 (d) are met to permit  $\lambda > 0.75$ .

<sup>4</sup> $\left(\frac{c_b + K_{tr}}{d_b}\right) = 2.5$ ,  $\psi_t = 1.0$ ,  $\psi_e = 1.0$ ,  $\psi_s = 0.8$  for  $d_b < 20$ mm, 1.0 for  $d_b \geq 20$ mm.

<sup>5</sup> $l_d$  must be increased by 9.5% to account for  $\psi_g$  in ACI 318-19 25.4.2.4.  $\psi_g$  has been interpolated from Table 25.4.2.5 of ACI 318-10 for  $f_y = 72.5$  ksi.

**TABLE 32—DEVELOPMENT LENGTH FOR CANADIAN METRIC REINFORCING BARS IN HOLES DRILLED WITH A HAMMER DRILL AND CARBIDE BIT OR HILTI HOLLOW CARBIDE BIT <sup>1,2,4</sup>**

DESIGN INFORMATION	Symbol	Criteria Section of Reference Standard	Units	Bar size				
				10M	15M	20M	25M	30M
Nominal reinforcing bar diameter	$d_b$	CAN/CSA-G30.18 Gr. 400	mm (in.)	11.3 (0.445)	16.0 (0.630)	19.5 (0.768)	25.2 (0.992)	29.9 (1.177)
Nominal bar area	$A_b$	CAN/CSA-G30.18 Gr. 400	mm <sup>2</sup> (in <sup>2</sup> )	100.3 (0.16)	201.1 (0.31)	298.6 (0.46)	498.8 (0.77)	702.2 (1.09)
Development length for $f_y = 58$ ksi and $f'_c = 2,500$ psi (normal weight concrete) <sup>3</sup>	$l_d$	ACI 318-19 25.4.2.4 ACI 318-14 25.4.2.3 ACI 318-11 12.2.3	mm (in.)	315 (12.4)	445 (17.5)	678 (26.7)	876 (34.5)	1041 (41.0)
Development length for $f_y = 58$ ksi and $f'_c = 4,000$ psi (normal weight concrete) <sup>3</sup>	$l_d$	ACI 318-19 25.4.2.4 ACI 318-14 25.4.2.3 ACI 318-11 12.2.3	mm (in.)	305 (12.0)	353 (13.9)	536 (21.1)	693 (27.3)	823 (32.4)

For SI: 1 inch  $\equiv$  25.4 mm, 1 lbf = 4.448 N, 1 psi = 0.006897 MPa.  
For pound-inch units: 1 mm = 0.03937 inches, 1 N = 0.2248 lbf, 1 MPa = 145.0 psi

<sup>1</sup>Development lengths valid for static, wind, and earthquake loads (SDC A and B).

<sup>2</sup>Development lengths in SDC C through F must comply with ACI 318-19 and ACI 318-14 Chapter 18 or ACI 318-11 Chapter 21 and Section 4.2.4 of this report.

<sup>3</sup>For sand-lightweight concrete, increase development length by 33%, unless the provisions of ACI 318-19 25.4.2.5, ACI 318-14 25.4.2.4 or ACI 318-11 12.2.4 (d) are met to permit  $\lambda > 0.75$ .

<sup>4</sup> $\left(\frac{c_b + K_{tr}}{d_b}\right) = 2.5$ ,  $\psi_t = 1.0$ ,  $\psi_e = 1.0$ ,  $\psi_s = 0.8$  for  $d_b < 20$ M, 1.0 for  $d_b \geq 20$ M.





English  
Français  
Español  
Português

Hilti HIT-HY 200-A V3  
Hilti HIT-HY 200-R V3



**Warning**  
Contains: hydroxypropylmethacrylate (A)  
2,2'-(m-tolylimino)diethanol (A) 1,4-Butandiol-dimet-  
hacrylat (A) dibenzoyl peroxide (B) May cause an  
allergic skin reaction. (A, B) Causes serious eye  
irritation. (B) Very toxic to aquatic life with long lasting  
effects. (B)

Hilti HIT-HY 200-A/R V3

1		7		13		19	
2		8		14		20	
3		9		15		21	
4		10		16			
5		11		17			
6		12		18			

Rebar  $h_{ef} \geq 20d$

			$h_{ef}$		
HIT-HY 200-A	HDM, HDE	$\leq$ US #5	12 1/2 ... 37 1/2 [inch]	14°F...104°F	50°F...86°F
HIT-HY 200-R V3		$\leq$ EU 16mm	320 ... 960 [mm]	-10°C...40°C	10°C...30°C
		$\leq$ CAN 15M	320 ... 960 [mm]		
HIT-HY 200-A	HDE	$\leq$ US #5	12 1/2 ... 37 1/2 [inch]	14°F...104°F	32°F...86°F
HIT-HY 200-R V3		$\leq$ EU 16mm	320 ... 960 [mm]	-10°C...40°C	0°C...30°C
		$\leq$ CAN 15M	320 ... 960 [mm]		
HIT-HY 200-R V3	HDE	$\leq$ US #8	20 ... 60 [inch]	32°F...104°F	32°F...86°F
		$\leq$ EU 25mm	500 ... 1500 [mm]	0°C...40°C	0°C...30°C
		$\leq$ CAN 25M	504 ... 1512 [mm]		
HIT-HY 200-R V3	HDE	$\leq$ US #10	25 ... 75 [inch]	50°F...86°F	50°F...86°F
		$\leq$ EU 32mm	640 ... 1920 [mm]	10°C...30°C	10°C...20°C
		$\leq$ CAN 30M	598 ... 1794 [mm]		

			$h_{ef}$		
HIT-HY 200-A	HDM, HDE	$\leq$ US #5	12 1/2 ... 37 1/2 [inch]	14°F...104°F	50°F...86°F
HIT-HY 200-R V3		$\leq$ EU 16mm	320 ... 960 [mm]	-10°C...40°C	10°C...30°C
		$\leq$ CAN 15M	320 ... 960 [mm]		
HIT-HY 200-A	HDE	$\leq$ US #5	12 1/2 ... 37 1/2 [inch]	14°F...104°F	32°F...86°F
HIT-HY 200-R V3		$\leq$ EU 16mm	320 ... 960 [mm]	-10°C...40°C	0°C...30°C
		$\leq$ CAN 15M	320 ... 960 [mm]		
HIT-HY 200-R V3	HDE	$\leq$ US #8	20 ... 39 3/8 [inch]	32°F...104°F	32°F...86°F
		$\leq$ EU 25mm	500 ... 1000 [mm]	0°C...40°C	0°C...30°C
		$\leq$ CAN 25M	504 ... 1000 [mm]		

Hilti HIT-HY 200-A/R V3

		HY 200-A V3		HIT-Z	
[°C]	[°F]	Rebar	HIT-Z	Rebar	HIT-Z
-10...-5	14...23	1.5 h	7 h		
-4...0	24...32	50 min	4 h		
1...5	33...41	25 min	2 h		
6...10	42...50	15 min	75 min	15 min	75 min
11...20	51...68	7 min	45 min	7 min	45 min
21...30	69...86	4 min	30 min	4 min	30 min
31...40	87...104	3 min	30 min	3 min	30 min

		HY 200-R V3		HIT-Z	
[°C]	[°F]	Rebar	HIT-Z	Rebar	HIT-Z
-10...-5	14...23	3 h	20 h		
-4...0	23...32	90 min	8 h		
1...5	32...41	45 min	4 h		
6...10	41...50	30 min	2.5 h	30 min	2.5 h
11...20	50...68	15 min	1.5 h	15 min	1.5 h
21...30	69...86	9 min	1 h	9 min	1 h
31...40	87...104	6 min	1 h	6 min	1 h

$h_{ef}$ [inch]	$h_{ef}$ [mm]	$t_{toughen}$ max	$t_{blowing}$ min
0 ... 4	0 ... 100	10 sec	30 sec
4.01 ... 8	101 ... 200	20 sec	40 sec
8.01 ... 12	201 ... 300	30 sec	50 sec
12.01 ... 16	301 ... 400	40 sec	60 sec
16.01 ... 20	401 ... 500	50 sec	70 sec
20.01 ... 25	501 ... 600	60 sec	80 sec

$t_{toughen} [sec] = h_{ef} [inch] / 2.5$       $t_{toughen} [sec] = h_{ef} [mm] / 10$

3

Hilti HIT-HY 200-A/R V3

Fractional/Imperial

d [inch]	US Rebar		CA Rebar		HIS-N, -RN					
	HY 200-A V3	HY 200-R V3	HY 200-A V3	HY 200-R V3	d [inch]	$h_{ef}$ [inch]	$h_{ef}$ [inch]	d [inch]	$h_{ef}$ [inch]	$T_{max}$ [lb-ft]
#3	2 28 ... 22 1/2	3 28								9 1/2
#4	2 34 ... 30	4 1/2	10 M	70 ... 678						5 8
#5	3 18 ... 37 1/2	5 5/8	15 M	80 ... 960	3/8	4 3/8	4 3/8	7/16	3 8 ... 15 1/2	11 1/2
#6	3 1/2 ... 15	6 3/4			1/2	5	5	9/16	1/2 ... 1 3/16	5 3/8
#8		15 ... 46	20 M	90 ... 990						7 8
#7	3 1/2 ... 17 1/2			90 ... 1170						1
#7	17 1/2 ... 62 1/2				5/8	6 3/4		1 1/16	5/8 ... 1 1/2	5 8
#8	4 ... 20									1 1/8
#8		20 ... 60	25 M	101 ... 504	3/4	8 1/8		1 3/16	3/4 ... 1 7/8	1 1/4
#8	4 1/2 ... 22 1/2	4 1/2 ... 67 1/2		101 ... 1512						1 3/8
#10	5 ... 25	5 ... 75	30 M	120 ... 696						1 1/2

ø d [inch]	7/16	1/2	9/16	5/8	11/16	3/4	7/8	1	1 1/8	1 1/4	1 3/8	1 1/2
HIT-RB	7/16	1/2	9/16	5/8	11/16	3/4	7/8	1	1 1/8	1 1/4	1 3/8	1 1/2
HIT-SZ	-	1/2	9/16	5/8	11/16	3/4	7/8	1	1 1/8	1 1/4	1 3/8	1 1/2
HIT-DL	-	1/2	9/16	5/8	11/16	3/4	7/8	1	1	1	1 3/8	1 3/8
HIT-OHC	387551											
TE-YRT	387552											

HIT-DL:  $h_{ef} > 10"$      HIT-RB:  $h_{ef} > 20d$



4

FIGURE 6—MANUFACTURER'S PRINTED INSTALLATION INSTRUCTIONS (MPII)

Fractional/Imperial		Hilti HIT-HY 200-A/R V3											
● HAS / HAS-E / HIT-V					● HIT-Z, HIT-Z-R								
d [inch]	$h_w$ [inch]	$h_w$ [inch]	$T_{hw}$ [lb-ft]	$d_1$ [inch]	$d_2$ [inch]	d [inch]	$h_w$ [inch]	$h_w$ [inch]	$T_{hw}$ HIT-Z [lb-ft]	$T_{hw}$ HIT-Z-R [lb-ft]	$d_1$ [inch]	$d_2$ [inch]	$d_3$ [inch]
3/8	2.38...7.12	3.38	≤15	1/2	7/16	3/8	2.38...4.12	3.38	15	30	1/2	7/16	7/16
1/2	2.34...10	4.12	≤30	5/8	9/16	1/2	2.34...6	4.12	30	60	5/8	9/16	9/16
5/8	3.18...12.1/2	5.98	≤60	13/16	11/16	5/8	3.24...7.1/2	5.98	60	120	13/16	11/16	3/4
3/4	3.1/2...15	6.34	≤100	15/16	13/16	3/4	4...8.1/2	6.34	110	165	15/16	13/16	7/8
7/8	3.1/2...17.1/2	6.34	≤125	1 1/8	19/16								1
1	4...20	-	≤150	1 1/4	1.18								1.18
													1.14
1/4	5...25	-	≤200	1 1/2	1.38								1.38
													1.12

HIT-RE-M				HIT-OHW
Art. No.				Art. No.
337111				387550

$\emptyset$			
$d_3$ [inch]	[inch]	Art. No. 381215	$\geq 6$ bar/90 psi @ 6 m <sup>3</sup> /h $\geq 140$ m <sup>3</sup> /h/ $\geq 82$ CFM
7/8"...1 1/4"	2 1/4"...20"	✓	
1 1/4"...1 1/2"	4"...25"	-	

Hilti HIT-HY 200-A/R V3							Metric Values						
● Rebar				● HIS-N, -RN			● HAS-U / HIT-V						
d [mm]	$h_w$ [mm]	d [mm]	$h_w$ [mm]	d [mm]	$h_w$ [mm]	$T_{hw}$ [Nm]	d [mm]	$h_w$ [mm]	$T_{hw}$ [Nm]	$d_1$ [mm]	$d_2$ [mm]	$d_3$ [mm]	$\emptyset d_3$ [mm]
8	60...480						M8	60-160	≤10	11	9	10	
10	60...600						M10	60-200	≤20	14	12	12	
12	70...720						M12	70-240	≤40	16	14	14	
14	75...1000						M16	80-320	≤80	20*	18	18	
16	90...1000						M20	90-400	≤150	24*	22	22	
18	85...1000						M24	96-480	≤200	30*	26	28	
20	90...1000						M27	108-540	≤270	32*	30	30	
22	95...1000						M30	120-600	≤300	37*	33	35	
24/25	96/100...1000												
28/28	104/112...1000												
30	120...1000												
32	126...1000												

Metric Values		Hilti HIT-HY 200-A/R V3									
● HAS-U / HIT-V / HAS / HAS-E					● HIT-Z, -R						
d [mm]	$h_{min}$ [mm]	$T_{hw}$ HIT-Z [Nm]	$T_{hw}$ HIT-Z-R [Nm]	$d_1$ [mm]	$d_2$ [mm]	$\emptyset d_3$ [mm]	HIT-RB	HIT-SZ	HIT-DL	HIT-OHC	TE-YRT
M8	60-96	10	30	11	9	10	10				
M10	60-120	25	55	14	12	12	12				
M12	60-144	40	75	16	14	14	14				
							16				
M16	96-192	80	155	20*	18	18	18				18
							20				20
M20	100-220	150	215	24*	22	22	22				22
							25				25
							28				28
							30				30
							32				32
							35				35

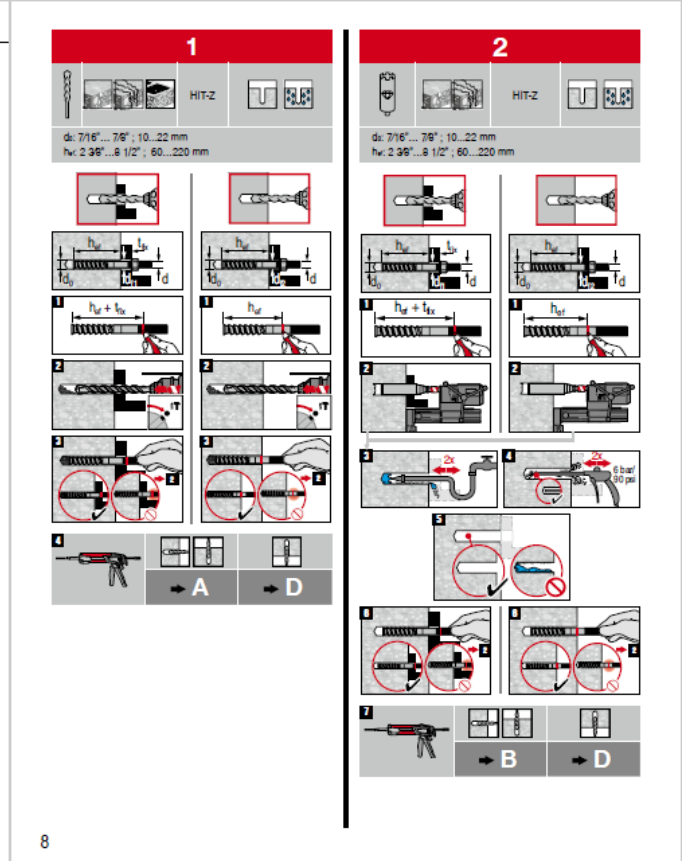

FIGURE 6—MANUFACTURER'S PRINTED INSTALLATION INSTRUCTIONS (MPII) (Continued)

### 3

HIT-Z, HAG, HAG-E, HAS-U, HIT-V, HIS-N, Rebar

di: 7/16" ... 1 1/8" ... 10 ... 35 mm  
hv: 2 3/8" ... 39 3/8" ... 60 ... 1000 mm

### 4

HAG, HAG-E, HAS-U, HIT-V, HIS-N, Rebar

di: 7/16" ... 1 1/2" ... 10 ... 40 mm  
hv: 2 3/8" ... 75 1/2" ... 60 ... 1920 mm

### 5

HAG, HAG-E, HAS-U, HIT-V, HIS-N, Rebar

di: 5/8" ... 1 1/4" ... 18 ... 35 mm  
hv: 3 1/8" ... 25" ... 80 ... 600 mm

### 6

HAS, HAG-E, HAS-U, HIT-V, Rebar

di: 7/16" ... 1 3/4" ... 10 ... 40 mm  
hv: 2 3/8" ... 10" ... 60 ... 250 mm

### A

HIT-RE-M

di: 2 3/8" ... 9 1/2" ... 60 ... 220mm

### B

HIT-Z, HAG, HAG-E, HAS-U, HIT-V, HIS-N / Rebar

HIT-RE-M

di: 2 3/8" ... 9 7/8" ... 60 ... 250mm

9

10

### C

HAG, HAG-E, HAS-U/HIT-V, HIS-N, Rebar

di: 2 3/8" ... 75 1/2" ... 60 ... 1920mm

HIT-RE-M, HIT-SZ

### D

HIT-Z, HAG, HAG-E, HAS-U/HIT-V, HIS-N/Rebar

HIT-RE-M, HIT-SZ, HIT-OWH, HIT-OHC

### E

HIT-RE-M, HIT-SZ, HIT-OWH, HIT-OHC

### F

HIT-RE-M, HIT-SZ, HIT-OWH, HIT-OHC

11

12

**Hilti HIT-HY 200-A/R V3**

**EN Adhesive anchoring system for rebar and anchor fastenings in concrete.**

**Hilti HIT-HY 200-A/-R V3**

Contains: Hydroxypropylmethacrylate (A), 1,4-Butandiol-dimethacrylate (A), Dibenzoylperoxid (B), 2,2-(m-lylimino)diethanol (A)



**Warning** May cause an allergic skin reaction. (A, B) | Causes serious eye irritation. (B) | Very toxic to aquatic life with long lasting effects. (B) | Do not get in eyes, on skin or on clothing. | Wear eye protection, protective clothing, protective gloves. | IF ON SKIN: Wash with plenty of water. | IF IN EYES: Rinse cautiously with water for several minutes. Remove contact lenses, if present and easy to do. Continue rinsing. | If skin irritation or rash occurs: Get medical advice/attention. | If eye irritation persists: Get medical advice/attention.

**Disposal considerations:** Empty packs: Leave the mixer attached and dispose of via the local Green Dot recovery system or EAK waste material code: 150102 plastic packaging Full or partially emptied packs: Must be disposed of as special waste in accordance with official regulations. EAK waste material code: 08 04 09\* waste adhesives and sealants containing organic solvents or other dangerous substances. or EAK waste material code: 20 01 27\* paint, inks, adhesives and resins containing dangerous substances.

**Product information:** Always keep these instructions together with the product even when given to other persons. **Material Safety Data Sheet:** Review the MSDS before use. **Check expiration date:** See imprint on foil pack manifold (month/year). Do not use after product. **Foil pack temperature during usage:** 0 °C to 40 °C / 32 °F to 104 °F. **Base material temperature at time of installation:** HAS-U, HIT-V, HIS, Rebar: between -10 °C and 40 °C / 14 °F and 104 °F; HIT-Z: between +5 °C and 40 °C / 41 °F and 104 °F. **Conditions for transport and storage:** Keep in a cool, dry and dark place between 5 °C and 25 °C / 41 °F and 77 °F. For any application not covered by this document / beyond values specified, please contact Hilti. **Partly used foil packs must remain in the cassette** and has to be used within **4 weeks**. Leave the mixer attached on the foil pack manifold and store within the cassette under the recommended storage conditions. If reused, attach a new mixer and discard the initial quantity of anchor adhesive.

Failure to observe these installation instructions, use of non-Hilti anchors, poor or questionable concrete conditions, or unique applications may affect the reliability or performance of the fastenings.

**NOTICE**

- ▲ The surface of the HIT-Z anchor rod must not be altered in any way.
- ▲ The thread of HIT-Z must stay free from dirt and dust during the installation procedure and its cones must be fully embedded into mortar (especially at minimum embedment). Torque moment must always be applied on HIT-Z nut and washer installed above a solid basaltic laying on concrete.
- ▲ Improper handling may cause mortar splashes. Always wear safety glasses, gloves and protective clothes during installation. | Never start dispensing without a mixer properly screwed on. | Attach a new mixer prior to dispensing a new foil pack (ensure snug fit). | Use only the type of mixer (HIT-RE-M) supplied with the adhesive. Do not modify the mixer in any way. | Never use damaged foil packs and/or damaged or unclear foil pack holders (cassettes).
- ▲ Poor load values / potential failure of fastening points due to inadequate borehole cleaning. Hilti hollow drill bits TE-CD, TE-YD must be used in conjunction with a properly maintained Hilti vacuum cleaner with model and suction capacity (volumetric flow rate) as specified in the accessory table. | The boreholes must be free of debris, dust, water, ice, oil, grease and other contaminants prior to adhesive injection. | For blowing out the borehole – blow out with oil free air until return air stream is free of noticeable dust. | For flushing the borehole – flush with water line pressure until water runs clear. | For brushing the borehole – only use specified wire brush. The brush must resist insertion into the borehole – if not the brush is too small and must be replaced. | Important! Remove all water from the borehole and blow out with oil free compressed air until borehole is completely dried before mortar injection (not applicable to hammer drilled hole in underwater application). | Do not exceed the roughening time when roughening the drilled hole!

- ▲ Ensure that boreholes are filled from the back of the borehole without forming air voids. If necessary use the accessories / extensions to reach the back of the borehole. | For overhead applications use the overhead accessories HIT-SZ and take special care when inserting the fastening element. Excess adhesive may be forced out of the borehole. Make sure that no mortar drips onto the installer. | In water saturated concrete it is required to set the anchor immediately after cleaning the borehole.
- ▲ Not adhering to these setting instructions can result in failure of fastening points!

FIGURE 6—MANUFACTURER'S PRINTED INSTALLATION INSTRUCTIONS (MPII) (Continued)

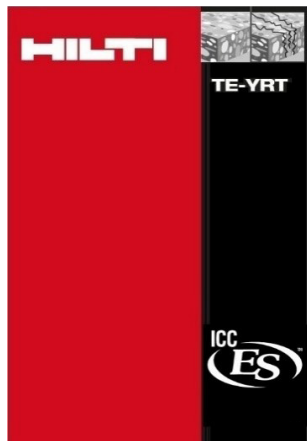

4.1	HILTI Ø d <sub>0</sub> [mm]	TE-YRT
	18	TE-YRT 18/320
	20	TE-YRT 20/320
	22	TE-YRT 22/400
	25	TE-YRT 25/400
	28	TE-YRT 28/480
	30	TE-YRT 30/540
	32	TE-YRT 32/500
	35	TE-YRT 35/600
	HILTI Ø d <sub>0</sub> [inch]	TE-YRT
	3/4"	TE-YRT 3/4" / 12 1/2"
	7/8"	TE-YRT 7/8" / 15"
	1"	TE-YRT 1" / 17 1/2"
	1 1/8"	TE-YRT 1 1/8" / 20"
	1 3/8"	TE-YRT 1 3/8" / 25"

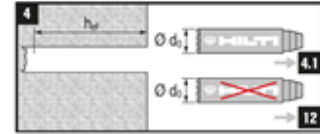
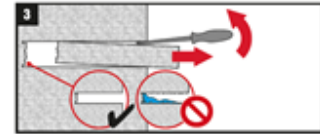
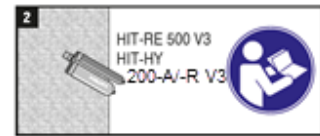
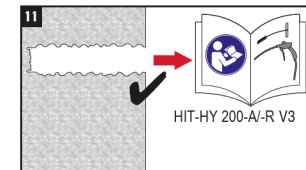
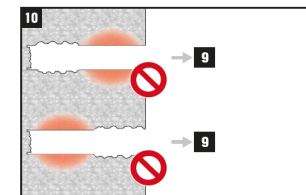
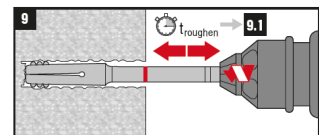
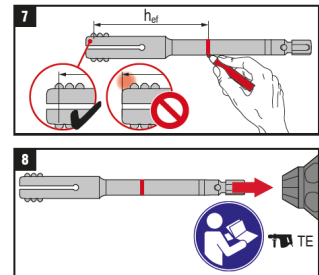
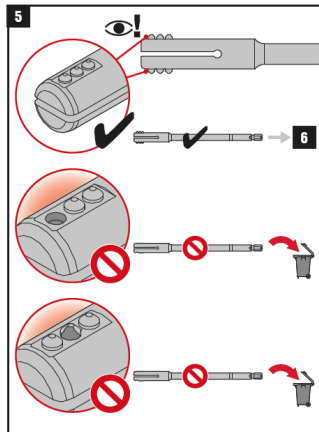
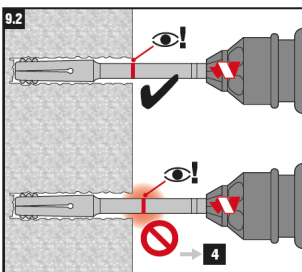
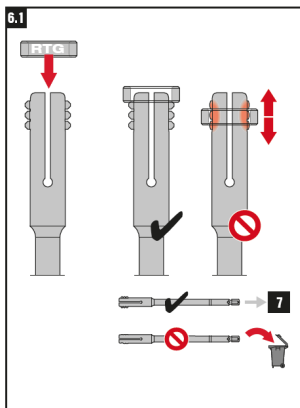

6	TE-YRT	(i) RTG
	TE-YRT 18/320	RTG 18
	TE-YRT 20/320	RTG 20
	TE-YRT 22/400	RTG 22
	TE-YRT 25/400	RTG 25
	TE-YRT 28/480	RTG 28
	TE-YRT 30/540	RTG 30
	TE-YRT 32/500	RTG 32
	TE-YRT 35/600	RTG 35
	TE-YRT	(i) RTG
	TE-YRT 3/4" / 12 1/2"	RTG 3/4"
	TE-YRT 7/8" / 15"	RTG 7/8"
	TE-YRT 1" / 17 1/2"	RTG 1"
	TE-YRT 1 1/8" / 20"	RTG 1 1/8"
	TE-YRT 1 3/8" / 25"	RTG 1 3/8"

9.1	h <sub>ef</sub> [mm]	t <sub>roughen</sub> (= h <sub>ef</sub> /10)
	0 ... 100	10 sec
	101 ... 200	20 sec
	201 ... 300	30 sec
	301 ... 400	40 sec
	401 ... 500	50 sec
	501 ... 600	60 sec
	h <sub>ef</sub> [inch]	t <sub>roughen</sub> (= h <sub>ef</sub> ·2.5)
	0 ... 4	10 sec
	4.01 ... 8	20 sec
	8.01 ... 12	30 sec
	12.01 ... 16	40 sec
	16.01 ... 20	50 sec
	20.01 ... 25	60 sec

12	HILTI Ø d <sub>0</sub> [mm]	TE-YRT
	17.9 ... 18.2	TE-YRT 18/320
	19.9 ... 20.2	TE-YRT 20/320
	21.9 ... 22.2	TE-YRT 22/400
	24.9 ... 25.2	TE-YRT 25/400
	27.9 ... 28.2	TE-YRT 28/480
	29.9 ... 30.2	TE-YRT 30/540
	31.9 ... 32.2	TE-YRT 32/500
	34.9 ... 35.2	TE-YRT 35/600
	HILTI Ø d <sub>0</sub> [inch]	TE-YRT
	0.764 ... 0.776	TE-YRT 3/4" / 12 1/2"
	0.862 ... 0.874	TE-YRT 7/8" / 15"
	1.008 ... 1.020	TE-YRT 1" / 17 1/2"
	1.146 ... 1.157	TE-YRT 1 1/8" / 20"
	1.374 ... 1.386	TE-YRT 1 3/8" / 25"

FIGURE 6—MANUFACTURER'S PRINTED INSTALLATION INSTRUCTIONS (MPII) (Continued)

**DIVISION: 03 00 00—CONCRETE**

Section: 03 16 00—Concrete Anchors

**DIVISION: 05 00 00—METALS**

Section: 05 05 19—Post-Installed Concrete Anchors

**REPORT HOLDER:**

HILTI, INC.

**EVALUATION SUBJECT:****HILTI HIT-HY 200 V3 ADHESIVE ANCHORS AND POST INSTALLED REINFORCING BAR CONNECTIONS IN CONCRETE****1.0 REPORT PURPOSE AND SCOPE****Purpose:**

The purpose of this evaluation report supplement is to indicate that the Hilti HIT HY 200 Adhesive Anchoring System and Post-Installed Reinforcing Bar System for cracked and uncracked concrete, described in ICC-ES evaluation report [ESR-4868](#), has also been evaluated for compliance with the codes noted below as adopted by the Los Angeles Department of Building and Safety (LADBS).

**Applicable code editions:**

- 2020 *City of Los Angeles Building Code* (LABC)
- 2020 *City of Los Angeles Residential Code* (LARC)

**2.0 CONCLUSIONS**

The Hilti HIT-HY 200 V3 Adhesive Anchoring System and Post-Installed Reinforcing Bar System for cracked and uncracked concrete, described in Sections 2.0 through 7.0 of the evaluation report [ESR-4868](#), complies with LABC Chapter 19, and LARC, and is subjected to the conditions of use described in this supplement.

**3.0 CONDITIONS OF USE**

The Hilti HIT HY 200 V3 Adhesive Anchoring System and Post-Installed Reinforcing Bar System described in this evaluation report supplement must comply with all of the following conditions:

- All applicable sections in the evaluation report [ESR-4868](#).
- The design, installation, conditions of use and labeling of the Hilti HIT-HY 200 V3 Adhesive Anchoring System and Post-Installed Reinforcing Bar System are in accordance with the 2018 *International Building Code*® (2018 IBC) provisions noted in the evaluation report [ESR-4868](#).
- The design, installation and inspection are in accordance with additional requirements of LABC Chapters 16 and 17, as applicable.
- Under the LARC, an engineered design in accordance with LARC Section R301.1.3 must be submitted.
- The allowable and strength design values listed in the evaluation report and tables are for the connection of the adhesive anchors and post-installed reinforcing bars to the concrete. The connection between the adhesive anchors or post-installed reinforcing bars and the connected members shall be checked for capacity (which may govern).
- For use in wall anchorage assemblies to flexible diaphragm, anchors shall be designed per the requirements of City of Los Angeles Information Bulletin P/BC 2020-071.

This supplement expires concurrently with the evaluation report, reissued November 2022 and revised March 2023.

**DIVISION: 03 00 00—CONCRETE**

**Section: 03 16 00—Concrete Anchors**

**DIVISION: 05 00 00—METALS**

**Section: 05 05 19—Post-Installed Concrete Anchors**

**REPORT HOLDER:**

HILTI, INC.

**EVALUATION SUBJECT:**

**HILTI HIT-HY 200 V3 ADHESIVE ANCHORS AND POST INSTALLED REINFORCING BAR CONNECTIONS IN CONCRETE**

**1.0 REPORT PURPOSE AND SCOPE**

**Purpose:**

The purpose of this evaluation report supplement is to indicate that the Hilti HIT-HY 200 V3 Adhesive Anchors and Post-Installed Reinforcing Bar System in Concrete, described in ICC-ES evaluation report ESR-4868, has also been evaluated for compliance with the codes noted below.

**Applicable code editions:**

- 2020 *Florida Building Code—Building*
- 2020 *Florida Building Code—Residential*

**2.0 CONCLUSIONS**

The Hilti HIT-HY 200 V3 Adhesive Anchor System and Post-Installed Reinforcing Bar System, described in Sections 2.0 through 7.0 of the ICC-ES evaluation report ESR-4868, comply with the *Florida Building Code—Building* and the *Florida Building Code—Residential*, provided the design requirements are in accordance with the *Florida Building Code—Building* or the *Florida Building Code—Residential*, as applicable. The installation requirements noted in ICC-ES evaluation report ESR-4868 for the 2018 *International Building Code*® meet the requirements of the *Florida Building Code—Building* or the *Florida Building Code—Residential*.

Use of the Hilti HIT-HY 200 V3 Adhesive Anchor System and Post-Installed Reinforcing Bar System have also been found to be in compliance with the High-Velocity Hurricane Zone provisions of the *Florida Building Code—Building* and the *Florida Building Code—Residential*, with the following condition:

- a) For anchorage to wood members, the connection subject to uplift must be designed for no less than 700 pounds (3114 N).

For products falling under Florida Rule 61G20-3, verification that the report holder's quality assurance program is audited by a quality assurance entity approved by the Florida Building Commission for the type of inspections being conducted is the responsibility of an approved validation entity (or the code official, when the report holder does not possess an approval by the Commission).

This supplement expires concurrently with the evaluation report, reissued November 2022 and revised March 2023.