



Austrian Institute of Construction Engineering
 Schenkenstrasse 4 | T+43 1 533 65 50
 1010 Vienna | Austria | F+43 1 533 64 23
 www.oib.or.at | mail@oib.or.at



European Technical Assessment

ETA-20/0834
 of 16.11.2020

General part

Technical Assessment Body issuing the European Technical Assessment

Österreichisches Institut für Bautechnik (OIB)
 Austrian Institute of Construction Engineering

Trade name of the construction product

Hilti HIT-RE 500 V4

Product family to which the construction product belongs

Glued-in rods for timber connections

Manufacturer

Hilti Corporation
 Feldkircherstrasse 100
 9494 Schaan
 Principality of Liechtenstein

Manufacturing plants

Hilti manufacturing plants

This European Technical Assessment contains

22 pages including 4 Annexes which form an integral part of this assessment.

This European Technical Assessment is issued in accordance with Regulation (EU) No 305/2011, on the basis of

European Assessment Document
 EAD 130006-00-0304 "Glued-in rods for timber connections".

Remarks

Translations of this European Technical Assessment in other languages shall fully correspond to the original issued document and should be identified as such.

Communication of this European Technical Assessment, including transmission by electronic means, shall be in full. However, partial reproduction may be made with the written consent of Österreichisches Institut für Bautechnik. Any partial reproduction has to be identified as such.

Specific parts

1 Technical description of the product

1.1 General

This European Technical Assessment (ETA) applies to the injection system for glued-in rods for timber connections "Hilti HIT-RE 500 V4". Hilti HIT-RE 500 V4 is composed of a two-component epoxy adhesive and metallic threaded or ripped rods. The metallic rod is placed into a drill hole which is filled with the two-component epoxy adhesive in order to reach compound between the metallic rod, the adhesive system and the timber element. The nominal diameter of the metallic rods d is $6 \text{ mm} \leq d \leq 30 \text{ mm}$. The minimum penetration length into the timber member L_p is $10 d$ or 100 mm .

The metallic rods conform to

- Metallic threaded rods made of carbon steel according to EN ISO 898-1 or stainless steel according to EN ISO 3506-1.
- Ribbed reinforcing steel rods in accordance with EN 10080 or according to national provisions that apply at the installation site.

Hilti HIT-RE 500 V4 and the components for its manufacturing correspond to the specifications given in Annex 1. The material characteristics, dimensions and tolerances of Hilti HIT-RE 500 V4, not indicated in these Annex, are given in the technical file¹ of the European Technical Assessment.

1.2 Components

1.2.1 Metallic threaded or ripped rods

The specification of the metallic rods is given in Annex 1 and Annex 2, Table 2. The metallic rods conform to:

- Metallic threaded rods made of carbon steel according to EN ISO 898-1 or stainless steel according to EN ISO 3506-1;
- Ribbed reinforcing steel rods in accordance with EN 10080 or according to national provisions that apply at the installation site.

1.2.2 Adhesive

The specification of the two-component epoxy adhesive is given in Annex 1 and Annex 2, Table 2.

The bond line thickness for glued in metallic threaded bars is $1 \text{ mm} \leq t_{bl} \leq 2 \text{ mm}$.

The bond line thickness for glued in ribbed reinforcing steel rods is $1.25 \text{ mm} \leq t_{bl} \leq 2.75 \text{ mm}$.

¹ The technical file of the European Technical Assessment is deposited at Österreichisches Institut für Bautechnik and, in so far as is relevant to the tasks of the notified product certification body involved in the assessment and verification of constancy of performance procedure, is handed over to the notified product certification body.

2 Specification of the intended use(s) in accordance with the applicable European Assessment Document (thereafter EAD)

2.1 Intended use

Hilti HIT-RE 500 V4 is intended to be used in load-bearing timber-to-timber, timber-to-concrete or timber-to-metal connections or as reinforcement rods in

- Glued laminated timber or glued solid timber according to EN 14080,
- Cross laminated timber according to EN 16351 bonded at the edges and with lamellae thickness of 40 mm , or
- Laminated veneer lumber made of softwood according to EN 14374.

of wood species European spruce (*Picea abies*), pine (*Pinus sylvestris*) or fir (*Abies alba*).

The glued-in rods are mainly used in tension or compression. The load bearing timber structures are not subjected to temperatures of more than 60°C over a longer time period.

Hilti HIT-RE 500 V4 shall be subjected to static and quasi static actions only.

Hilti HIT-RE 500 V4 is intended to be used in service classes 1 and 2 according to EN 1995-1-1².

2.2 General assumptions

The injection system for glued-in rods for timber connections is manufactured in accordance with the provisions of the European Technical Assessment using the manufacturing process as identified in the inspection of the manufacturing plants by Österreichisches Institut für Bautechnik and laid down in the technical file.

The manufacturer shall ensure that the requirements in accordance with the Clauses 1, 2 and 3 as well as with the Annexes of the European Technical Assessment are made known to those who are concerned with design and execution of the works.

Bonding operations shall take place in the factory- or under factory-like conditions.

The surfaces to be bonded must be clean and free of adhesive-repellent substances such as oil, fats or release agents. The moisture content of wood on the adherent surfaces during gluing shall not exceed 15% and moisture content of wood on the adherent surfaces in use shall not exceed 18%. The temperature of the timber and adhesive during gluing may vary in between 15 and 30°C.

Design

The European Technical Assessment only applies to the manufacture and use of glued-in rods for timber connections. Verification of stability of the works including application of loads on the glued-in rods for timber connections is not subject to the European Technical Assessment.

The following conditions shall be observed:

- Design of glued-in rods for timber connections is carried out under the responsibility of an engineer experienced in such products.
- Design of the works shall account for the protection of the glued-in rods for timber connections.
- The glued-in rods for timber connections are installed correctly.

Design of glued-in rods for timber connections can be according to EN 1995-1-1, EN 1995-1-2 and TR 070, taking into account of Annex 1 and Annex 2 of the European Technical Assessment.

Standards and regulations in force at the place of use shall be considered.

Packaging, transport, storage, maintenance, replacement and repair

Concerning product packaging, transport, storage, maintenance, replacement and repair it is the responsibility of the manufacturer to undertake the appropriate measures and to advise his clients

² Reference documents are listed in Annex 4.

on the transport, storage, maintenance, replacement and repair of the product as he considers necessary.

Installation

It is assumed that the product will be installed according to the manufacturer's instructions, see Annex 3.

During installation the following parameters shall be recorded:

- Wood moisture content
- Temperature during bonding and curing
- Adhesive batch and storage life
- Start and end time of the bonding operation

For a drill hole diameter greater than $d + 2$ mm appropriate means for centering shall be provided e.g. by placement of spacers at both ends of the bond length.

2.3 Assumed working life

The provisions made in the European Technical Assessment (ETA) are based on an assumed intended working life of Hilti HIT-RE 500 V4 of 50 years, when installed in the works, provided that the glued-in rods for timber connections are subject to appropriate installation, use and maintenance (see Clause 2.2). These provisions are based upon the current state of the art and the available knowledge and experience³.

The indications given as to the working life of the construction product cannot be interpreted as a guarantee neither given by the product manufacturer or his representative nor by EOTA nor by the Technical Assessment Body, but are regarded only as a means for choosing the appropriate products in relation to the expected economically reasonable working life of the works.

³ The real working life of a product incorporated in a specific works depends on the environmental conditions to which that works is subject, as well as on the particular conditions of the design, execution, use and maintenance of that works. Therefore, it cannot be excluded that in certain cases the real working life of the product can also be shorter than the assumed working life.

3 Performance of the product and reference to the methods used for its assessment

3.1 Essential characteristics of the product

Table 1: Essential characteristics of the product and assessment methods

No	Essential characteristic	Product performance
Basic requirement for construction works 1: Mechanical resistance and stability ¹⁾		
1	Temperature behaviour of the adhesive	No performance assessed.
2	Bond strength of adhesive-wood interface	Annex 2
3	Pulling resistance (Bond shear strength of glued-in steel rods)	Annex 2
4	Embedment strength	No performance assessed.
5	Shear resistance	No performance assessed.
6	Creep and duration of load	Annex 2
7	Bond creep rupture test at very high and low moisture content	Annex 2
8	Bond temperature resistance	Annex 2
Basic requirement for construction works 2: Safety in case of fire		
9	Reaction to fire	Annex 2
10	Resistance to fire	No performance assessed.
Basic requirement for construction works 3: Hygiene, health and the environment		
11	Content emission and/or release of dangerous substances	No performance assessed.
¹⁾ These characteristics also relate to basic requirement for construction works 4.		

3.2 Assessment methods

3.2.1 General

The assessment of the essential characteristics in Clause 3.1 of Hilti HIT-RE 500 V4 for the intended use, and in relation to the requirements for mechanical resistance and stability, for safety in case of fire, for hygiene, health and the environment and for safety and accessibility in use in the sense of the basic requirements for construction works № 1, 2, 3 and 4 of Regulation (EU) № 305/2011 has been made in accordance with the European Assessment Document EAD 130006-00-0304, Glued-in rods for timber connections.

3.2.2 Identification

The European Technical Assessment for Hilti HIT-RE 500 V4 is issued on the basis of agreed data that identify the assessed product. Changes to materials, to composition, to characteristics of the product, or to the production process could result in these deposited data being incorrect. Österreichisches Institut für Bautechnik should be notified before the changes are implemented, as an amendment of the European Technical Assessment is possibly necessary.

4 Assessment and verification of constancy of performance (thereafter AVCP) system applied, with reference to its legal base

4.1 System of assessment and verification of constancy of performance

According to Commission Decision 97/176/EC the system of assessment and verification of constancy of performance to be applied to Hilti HIT-RE 500 V4 is System 1. System 1 is detailed in Commission Delegated Regulation (EU) № 568/2014 of 18 February 2014, Annex, 1.2., and provides for the following items:

- (a) The manufacturer shall carry out
 - (i) factory production control;
 - (ii) further testing of samples taken at the manufacturing plant by the manufacturer in accordance with a prescribed test plan⁴;
- (b) The notified product certification body shall decide on the issuing, restriction, suspension or withdrawal of the certificate of constancy of performance of the construction product on the basis of the outcome of the following assessments and verifications carried out by that body:
 - (i) an assessment of the performance of the construction product carried out on the basis of testing (including sampling), calculation, tabulated values or descriptive documentation of the product;
 - (iii) initial inspection of the manufacturing plant and of factory production control;
 - (iv) continuous surveillance, assessment and evaluation of factory production control.

4.2 AVCP for construction products for which a European Technical Assessment has been issued

Notified bodies undertaking tasks under System 1 shall consider the European Technical Assessment issued for the construction product in question as the assessment of the performance of that product. Notified bodies shall therefore not undertake the tasks referred to in point 4.1 (b)(i).

⁴ The prescribed test plan has been deposited with Österreichisches Institut für Bautechnik and is handed over only to the notified product certification body involved in the procedure for the assessment and verification of constancy of performance. The prescribed test plan is also referred to as control plan.

5 Technical details necessary for the implementation of the AVCP system, as provided for in the applicable European Assessment Document

5.1 Tasks for the manufacturer

5.1.1 Factory production control

In the manufacturing plant the manufacturer shall establish and continuously maintain a factory production control. All procedures and specification adopted by the manufacturer shall be documented in a systematic manner. The factory production control shall ensure the constancy of performances of Hilti HIT-RE 500 V4 with regard to the essential characteristics.

The manufacturer shall only use raw materials supplied with the relevant inspection documents as laid down in the control plan. The incoming raw materials shall be subject to controls by the manufacturer before acceptance. Check of incoming materials shall include control of inspection documents presented by the manufacturer of the raw materials.

The frequencies of controls conducted during manufacturing and on the assembled product are defined by taking account of the manufacturing process of the product and are laid down in the control plan.

The results of factory production control are recorded and evaluated. The records include at least the following data:

- Designation of the product, basic materials and components
- Type of control or test
- Date of manufacture of the product and date of testing of the product or basic materials or components
- Results of controls and tests and, if appropriate, comparison with requirements
- Name and signature of person responsible for factory production control

The records shall be kept at least for ten years time after the construction product has been placed on the market and shall be presented to the notified product certification body involved in continuous surveillance. On request they shall be presented to Österreichisches Institut für Bautechnik.

5.1.2 Declaration of performance

The manufacturer is responsible for preparing the declaration of performance. When all the criteria of the assessment and verification of constancy of performance are met, including the certificate of conformity issued by the notified product certification body, the manufacturer shall draw up a declaration of performance.

5.2 Tasks for the notified product certification body

5.2.1 Initial inspection of the manufacturing plant and of factory production control

The notified product certification body shall verify the ability of the manufacturer for a continuous and orderly manufacturing of Hilti HIT-RE 500 V4 according to the European Technical Assessment. In particular the following items shall be appropriately considered

- Personnel and equipment
- The suitability of the factory production control established by the manufacturer
- Full implementation of the control plan

5.2.2 Continuous surveillance, assessment and evaluation of factory production control

The notified product certification body shall visit the factory at least twice a year for routine inspection. In particular the following items shall be appropriately considered

- The manufacturing process including personnel and equipment
- The factory production control

- The implementation of the control plan

The results of continuous surveillance are made available on demand by the notified product certification body to Österreichisches Institut für Bautechnik. When the provisions of the European Technical Assessment and the control plan are no longer fulfilled, the certificate of constancy of performance is withdrawn by the notified product certification body.

Issued in Vienna on 16.11.2020
by Österreichisches Institut für Bautechnik

The original document is signed by:

Rainer Mikulits
Managing Director

electronic copy
electronic copy
electronic copy
electronic copy
electronic copy
electronic copy
electronic copy

Designation	Material
Metal parts made of zinc coated steel	
Threaded rod, HAS-U-5.8 (F), HIT-V-5.8 (F)	Strength class 5.8, $f_{uk} = 500 \text{ N/mm}^2$, $f_{yk} = 400 \text{ N/mm}^2$ Elongation at fracture ($l_0 = 5d$) > 8% ductile Electroplated zinc coated $\geq 5 \mu\text{m}$, (F) hot dip galvanized $\geq 45 \mu\text{m}$
Threaded rod, HAS-U-8.8 (F), HIT-V-8.8 (F)	Strength class 8.8, $f_{uk} = 800 \text{ N/mm}^2$, $f_{yk} = 640 \text{ N/mm}^2$ Elongation at fracture ($l_0 = 5d$) > 12% ductile Electroplated zinc coated $\geq 5 \mu\text{m}$, (F) hot dip galvanized $\geq 45 \mu\text{m}$
Hilti Meter rod, AM 8.8 (HDG)	Strength class 8.8, $f_{uk} = 800 \text{ N/mm}^2$, $f_{yk} = 640 \text{ N/mm}^2$ Elongation at fracture ($l_0 = 5d$) > 12% ductile, Electroplated zinc coated $\geq 5 \mu\text{m}$, (HDG) hot dip galvanized $\geq 45 \mu\text{m}$
Washer	Electroplated zinc coated $\geq 5 \mu\text{m}$, hot dip galvanized $\geq 45 \mu\text{m}$
Nut	Strength class of nut adapted to strength class of threaded rod. Electroplated zinc coated $\geq 5 \mu\text{m}$, hot dip galvanized $\geq 45 \mu\text{m}$
Metal parts made of stainless steel	
Threaded rod, HAS-U-R, HIT-V-R	For $\leq \text{M24}$: strength class 70, $f_{uk} = 700 \text{ N/mm}^2$, $f_{yk} = 450 \text{ N/mm}^2$ For $> \text{M24}$: strength class 50, $f_{uk} = 500 \text{ N/mm}^2$, $f_{yk} = 210 \text{ N/mm}^2$ Elongation at fracture ($l_0 = 5d$) > 8% ductile Stainless steel 1.4401, 1.4404, 1.4578, 1.4571, 1.4439, 1.4362 acc. to EN 10088-1
Washer	Stainless steel 1.4401, 1.4404, 1.4578, 1.4571, 1.4439, 1.4362 acc. to EN 10088-1
Nut	Strength class of nut adapted to strength class of threaded rod. Stainless steel 1.4401, 1.4404, 1.4578, 1.4571, 1.4439, 1.4362 acc. to EN 10088-1
Metal parts made of high corrosion resistant steel	
Threaded rod, HAS-U-HCR, HIT-V-HCR	For $\leq \text{M20}$: $f_{uk} = 800 \text{ N/mm}^2$, $f_{yk} = 640 \text{ N/mm}^2$ For $> \text{M20}$: $f_{uk} = 700 \text{ N/mm}^2$, $f_{yk} = 400 \text{ N/mm}^2$, Elongation at fracture ($l_0 = 5d$) > 8% ductile High corrosion resistant steel 1.4529, 1.4565 acc. to EN 10088-1
Washer	High corrosion resistant steel 1.4529, 1.4565 acc. to EN 10088-1
Nut	Strength class of nut adapted to strength class of threaded rod. High corrosion resistant steel 1.4529, 1.4565 acc. to EN 10088-1
Reinforcing bars (rebars)	
Rebar EN 1992-1-1:2004 and AC:2010, Annex C	Bars and de-coiled rods class B or C with f_{yk} and k according to NDP or NCI of EN 1992-1-1 $f_{uk} = f_{tk} = k \cdot f_{yk}$
Hilti HIT-RE 500 V4	
Annex 1	
Product description of Hilti HIT-RE 500 V4	
of European Technical Assessment ETA-20/0834 of 16.11.2020	

Table 2: Dimensions and specifications

Characteristic		Dimension / Specification
Hilti HIT-RE 500 V4		
Metallic threaded rods		
Metallic threaded bars of carbon steel or stainless steel	—	EN ISO 898-1 or EN ISO 3506-1
Ribbed reinforcing steel rods		EN 10080
Nominal diameter of the metallic threaded rods d in cross laminated timber	mm	$6 \leq d \leq 30$ $6 \leq d \leq 30$
Bond line thickness t_{bl} and diameter of the drill hole d_{dh}		
Metallic threaded bars	mm	$1 \leq t_{bl} \leq 2$ $d + 2 \leq d_{dh} \leq d + 4$
Ribbed reinforcing steel rods		$1.25 \leq t_{bl} \leq 2.75$ $d + 2.5 \leq d_{dh} \leq d + 5.5$
Minimum penetration length into the timber member L_p	mm	10 d or 100
Timber elements		
Glued laminated timber or glued solid timber		EN 14080
Cross laminated timber bonded at the edges and with lamellae thickness of 40 mm	—	EN 16351
Laminated veneer lumber		EN 14374
Wood species	—	European spruce (<i>Picea abies</i>), pine (<i>Pinus sylvestris</i>) or fir (<i>Abies alba</i>)
Moisture content of wood on adherent surfaces	%	during gluing ≤ 15 in use ≤ 18
Temperature of the timber / adhesive during gluing	°C	15 to 30
Mixing ratio of resin and hardener of two-component epoxy adhesive	—	3:1

Hilti HIT-RE 500 V4

Annex 2

Characteristic data of Hilti HIT-RE 500 V4

of European Technical Assessment
ETA-20/0834 of 16.11.2020

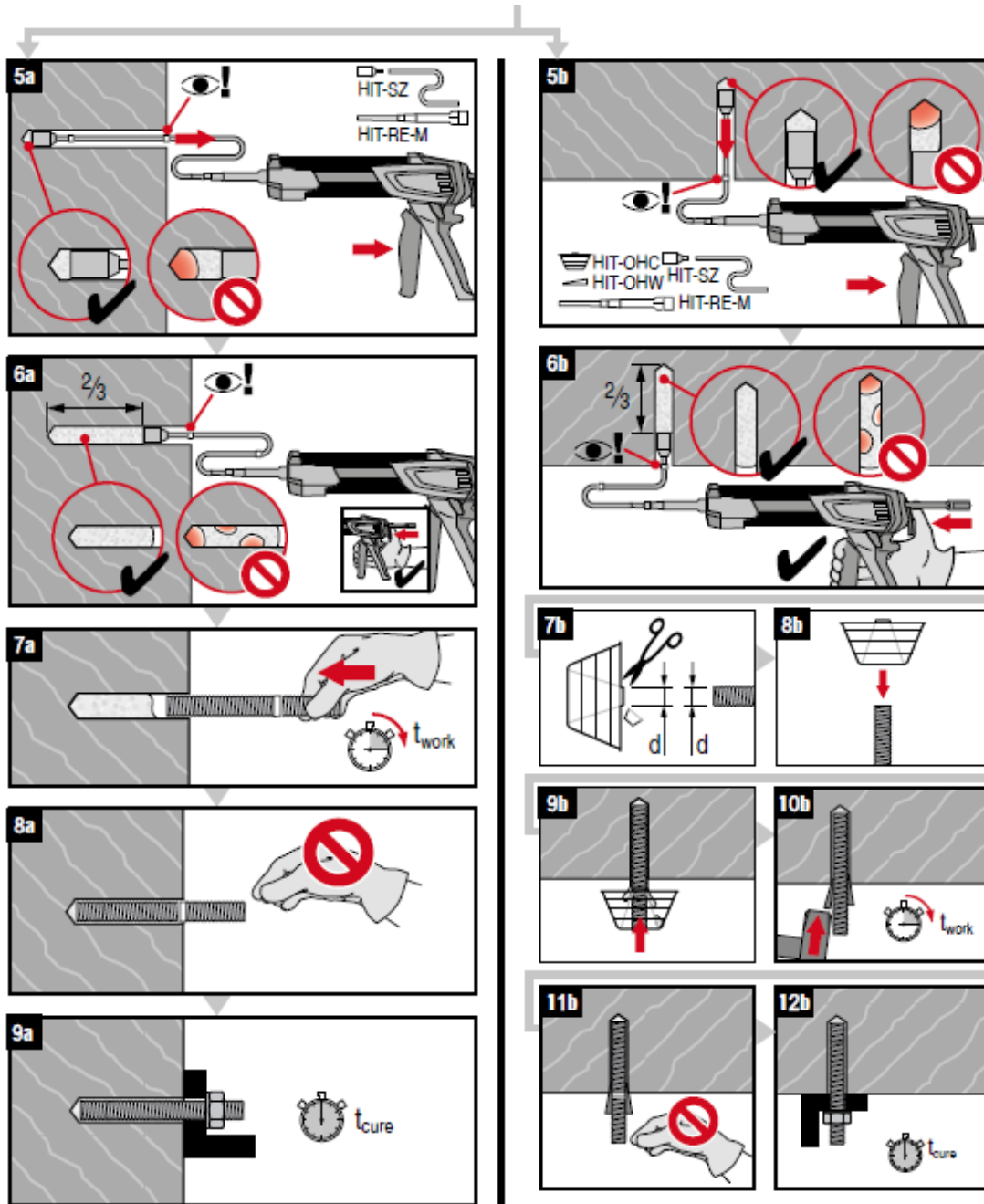

Hilti HIT-RE 500 V4

Annex 3

Installation of the glued-in rods

of European Technical Assessment
ETA-20/0834 of 16.11.2020

3a

$d_0:$
8...34 mm

$h_{ef}:$
 $\geq 10d/100\text{mm}$

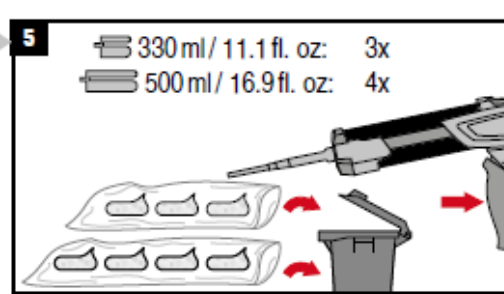
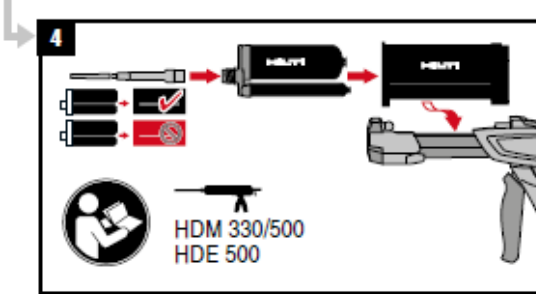
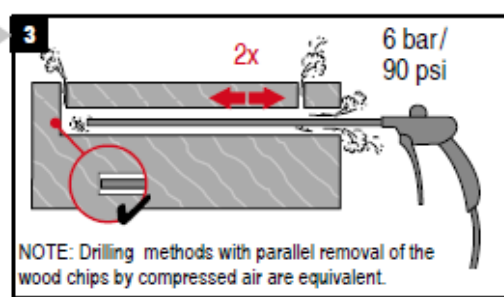
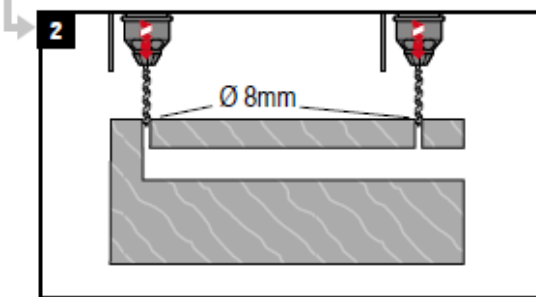
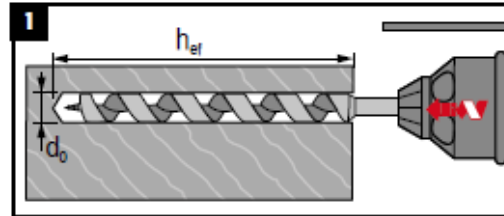

Hilti HIT-RE 500 V4	Annex 3
Installation of the glued-in rods	of European Technical Assessment ETA-20/0834 of 16.11.2020

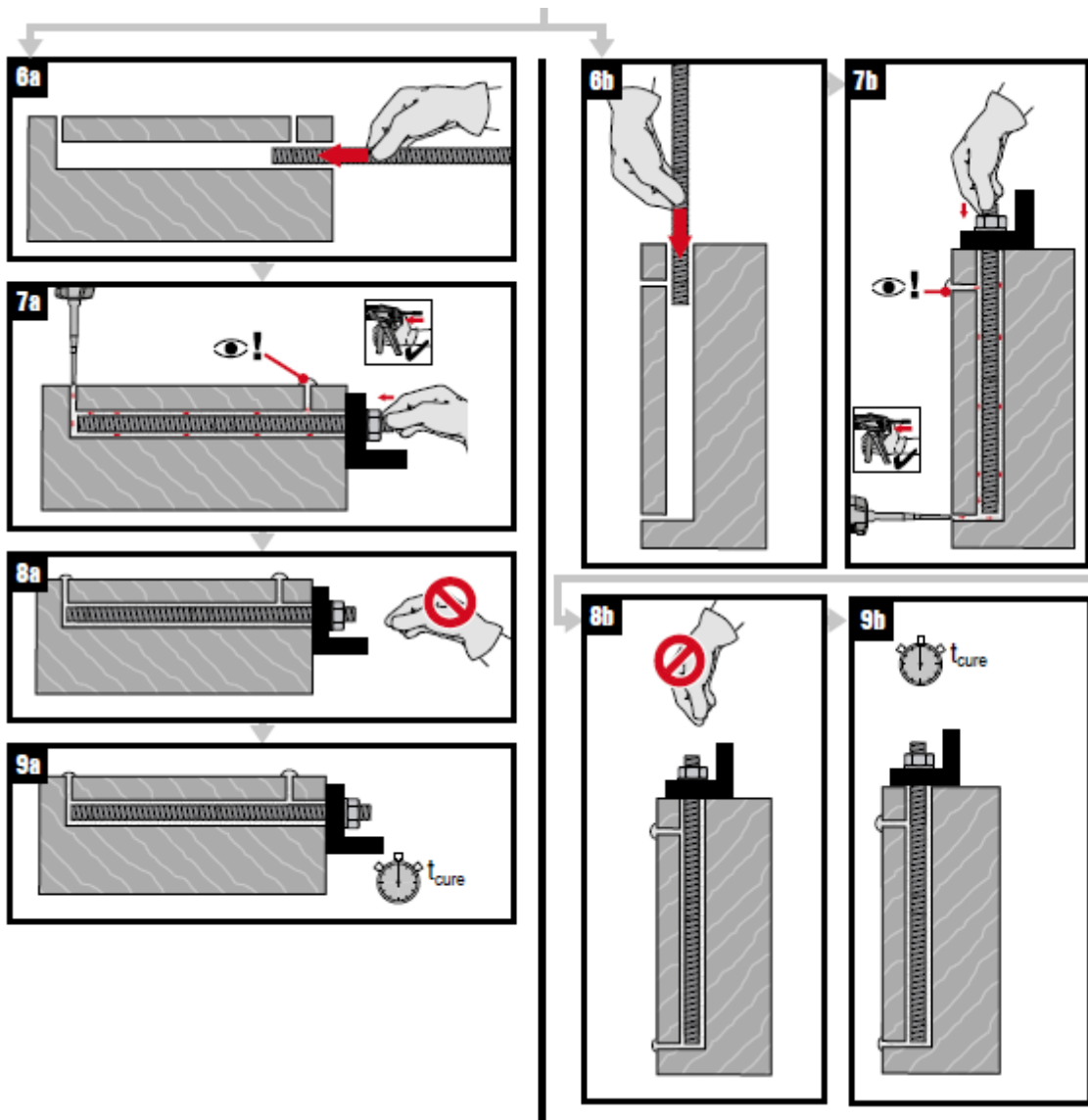

Hilti HIT-RE 500 V4

Annex 3

Installation of the glued-in rods

of European Technical Assessment
ETA-20/0834 of 16.11.2020

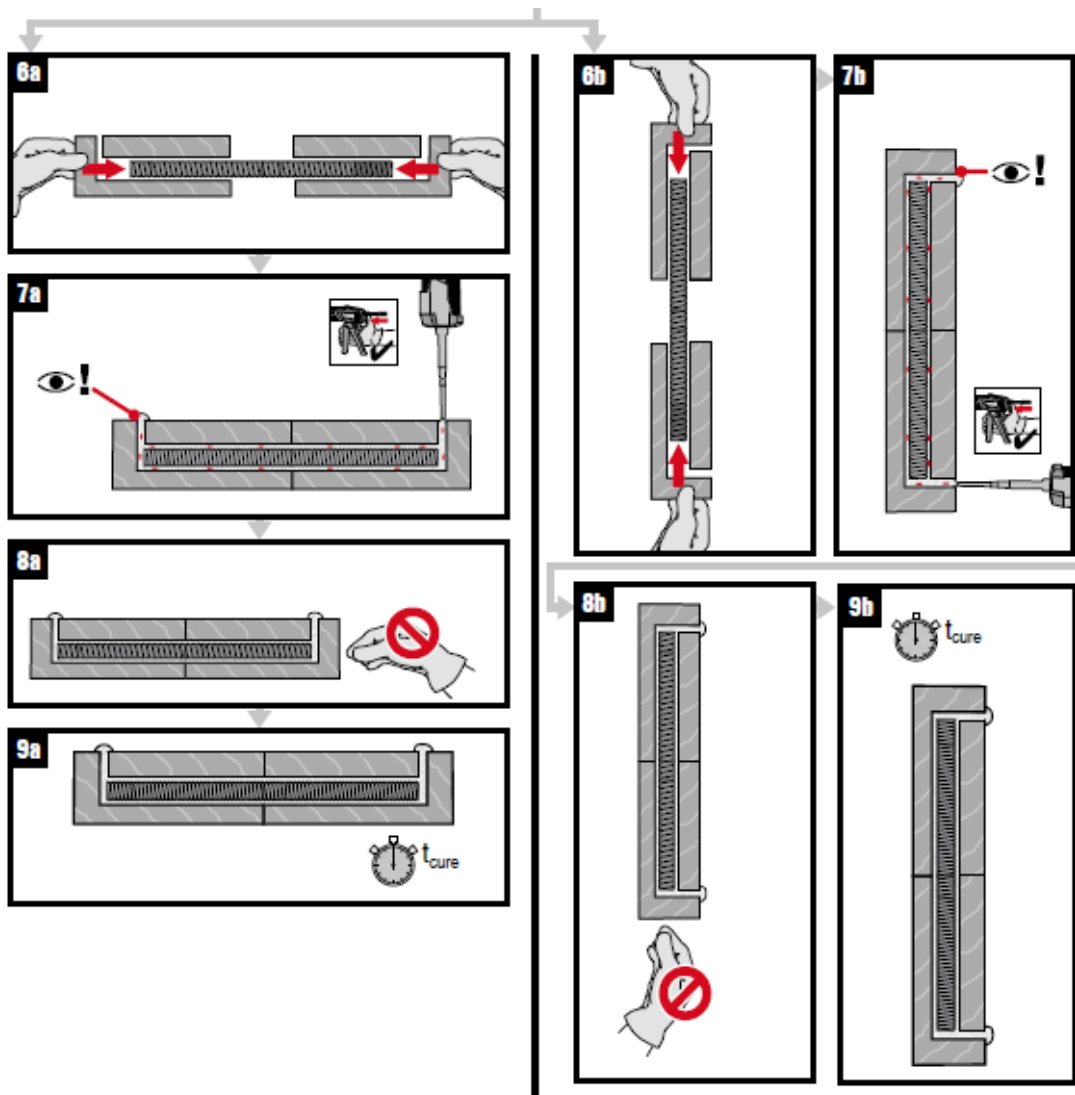

Hilti HIT-RE 500 V4

Annex 3

Installation of the glued-in rods

of European Technical Assessment
ETA-20/0834 of 16.11.2020

