



ICC-ES Evaluation Report ESR-1752

Reissued September 2021

This report is subject to renewal September 2023.

DIVISION: 03 00 00—CONCRETE
Section: 03 15 00—Concrete Accessories
Section: 03 16 00—Concrete Anchors

DIVISION: 04 00 00—MASONRY
Section: 04 05 19.16—Masonry Anchors

DIVISION: 05 00 00—METALS
Section: 05 05 23—Metal Fastenings

DIVISION: 09 00 00—FINISHES
Section: 09 22 16.23—Fasteners

REPORT HOLDER:

HILTI, INC.

EVALUATION SUBJECT:

**HILTI LOW-VELOCITY POWER-ACTUATED
FASTENERS**

1.0 EVALUATION SCOPE

Compliance with the following codes:

- 2021, 2018, 2015 and 2012 *International Building Code*® (IBC)
- 2021, 2018, 2015 and 2012 *International Residential Code*® (IRC)

For evaluation for compliance with codes adopted by the Los Angeles Department of Building and Safety (LADBS), see [ESR-1752 LABC and LARC Supplement](#).

Property evaluated:

Structural

2.0 USES

Hilti low-velocity power-actuated fasteners are used with powder-actuated, gas-driven or electro-mechanically driven tools to attach light-gage cold-formed steel framing and nonstructural components to base materials of normal weight concrete, sand-lightweight concrete, metal deck panels with sand-lightweight concrete fill, concrete masonry and structural steel. The fasteners are alternatives to the cast-in-place anchors described in IBC Section 1901.3 (2012 IBC Section 1908) for placement in concrete; the embedded anchors described in Section 8.1.3 of TMS 402, referenced in Section 2107 of the IBC,

respectively (Section 2.1.4 of TMS 402-11, referenced in Section 2107 of the 2012 IBC) for placement in masonry; and the welds and bolts used to attach materials to steel, described in IBC Sections 2204.1 and 2204.2, respectively. For structures regulated under the IRC, the fasteners may be used where an engineered design is submitted in accordance with IRC Section R301.1.3.

3.0 DESCRIPTION

3.1 Fasteners:

Hilti low-velocity power-actuated fasteners (PAFs) are manufactured from hardened steel complying with the manufacturer's quality documentation. See Table 1 for shank type, fastener dimensions and coating description. Maximum point length is the maximum specified length from the tip of the fastener to the location where the diameter of the shank becomes constant. Minimum effective shank length is the minimum specified length from the underside of the fastener head to the tip of the fastener.

3.2 Substrate Materials:

3.2.1 Concrete: Normalweight and sand-lightweight concrete must comply with IBC Chapter 19 or IRC Section R402.2, as applicable. The minimum concrete compressive strength at the time of fastener installation must be as noted in the applicable allowable load table.

3.2.2 Concrete Masonry: Concrete masonry units (CMUs) must be minimum 8-inch-thick (203 mm), and must comply with ASTM C90. Mortar must comply with ASTM C270. Grout must be course grout complying with ASTM C476. Concrete masonry walls must have minimum compressive strength, f'_m , of 1,500 psi (10.3 MPa). See Table 6 for applicable CMU density and mortar type.

3.2.3 Steel: Structural steel supports must comply with the minimum requirements of ASTM A36, ASTM A572 Grade 50 or ASTM A992, as applicable, and must have minimum yield and tensile strengths and thickness as noted in Table 2.

3.2.4 Steel Deck Panels: Steel deck panel properties and configurations must be as described in footnote 4 of Tables 4 and 5 and Figures 15 through 17.

4.0 DESIGN AND INSTALLATION

4.1 Design:

4.1.1 General: Selection of fasteners must take into consideration the applicable base material and the length

of the fastener. The minimum fastener length must be determined as follows:

- For installation into concrete, concrete-filled steel deck panels, concrete masonry and steel base materials, the minimum effective shank length shown in Table 1 must equal or exceed the sum of the thickness of the attached material and the minimum embedment depth (penetration) shown in the applicable tables in this report.
- For installation through steel base materials, the minimum effective shank length shown in Table 1 must equal or exceed the sum of the following: the thickness of the attached material, the thickness of the base material and the required point penetration shown in the applicable tables in this report.

4.1.2 Allowable Loads: The applicable allowable load tables for Hilti powder-actuated fasteners driven into different base materials may be determined by referencing Table 1.

The most critical applied loads, excluding seismic load effects, resulting from the load combinations in Section 2.4 of ASCE 7-16/S1 (referenced in 2021 IBC Section 1605.1) or 2021 IBC Section 1605.2 (Section 1605.3.1 or 1605.3.2 of the 2018, 2015 and 2012 IBC) must not exceed the allowable loads. For fasteners which are subjected to seismic loads, see Section 4.1.5 for additional information. The stress increases and load reductions described in 2021 IBC Section 1605.2 (2018, 2015 and 2012 IBC Section 1605.3) are not allowed.

Allowable shear loads and tension (pullout) loads in this report apply to the connection of the fastener to the base material. Other limit states applicable to the design of a connection, such as fastener pull-through (pull-over) and lateral bearing on the attached material, which are governed by the properties of attached materials, are outside the scope of this report. Design of the connection to the attached material must comply with the applicable requirements of the IBC.

4.1.3 Combined Loading: For fasteners subjected to both tension and shear loads, compliance with the following interaction equation must be verified:

$$(p/P_a) + (v/V_a) \leq 1$$

where:

- p = Actual applied tension load on fastener, lbf (N).
- P_a = Allowable tension load on fastener, lbf (N).
- v = Actual applied shear load on fastener, lbf (N).
- V_a = Allowable shear load on fastener, lbf (N).

4.1.4 Steel-to-steel Connections: When the Hilti fasteners listed in Table 2 are used in connections of two steel elements in accordance with Section J5 of AISI S100 (Section E5 of AISI S100-12 for the 2015 and 2012 IBC), connection capacity must be determined in accordance with Sections 4.1.4.1 and 4.1.4.2, as applicable.

4.1.4.1 Connection Strength—Tension: To determine tensile connection strength in accordance with Section J5.2 of AISI S100 (Section E5.2 of AISI S100-12), fastener tension strength, the pull-out strength and the pull-over strength must be known. These characteristics must be determined as follows:

- **Pull-out Strength:** See Table 2 for available pull-out strength.
- **Pull-over Strength:** The available pull-over strengths must be calculated in accordance with Section J5.2.3 of AISI S100 (Section E5.2.3 of AISI S100-12).

- **PAF Tensile Strength:** The allowable fastener tension strengths, determined in accordance with Section J5.2.1 of AISI S100 (Section E5.2.1 of AISI S100-12), exceed the allowable pull-out strengths in Table 2.

4.1.4.2 Connection Strength—Shear: To determine shear connection strength in accordance with Section J5.3 of AISI S100 (Section E5.3 of AISI S100-12), the fastener shear strength, bearing and tilting strength, pull-out strength in shear, net section rupture strength and shear strength limited by edge distance must be known. These characteristics must be determined as follows:

- **Bearing and Tilting Strength:** The available bearing and tilting strengths must be calculated in accordance with Section J5.3.2 of AISI S100 (Section E5.3.2 of AISI S100-12).
- **Pull-out Strength in Shear:** The available pull-out strength in shear must be the applicable allowable shear strength from Table 2, or must be calculated in accordance with Section J5.3.3 of AISI S100 (Section E5.3.3 of AISI S100-12).
- **Net Section Rupture Strength and Shear Strength Limited by Edge Distance:** The net section rupture strength must be determined in accordance with Section J5.3.4 of AISI S100 (Section E5.3.4 of AISI S100-12) and the shear strength limited by edge distance must be determined in accordance with Section J5.3.5 of AISI S100 (Section E5.3.5 of AISI S100-12).
- **PAF Shear Strength:** The allowable fastener shear strengths, determined in accordance with Section J5.3.1 of AISI S100 (Section E5.3.1 of AISI S100-12), exceed the allowable pull-out in shear strengths in Table 2.

4.1.5 Seismic Considerations: When subjected to seismic loads, the Hilti fasteners may be used as follows:

1. The Hilti fasteners may be used for attachment of nonstructural components listed in Section 13.1.4 of ASCE/SEI 7, which are exempt from the requirements of ASCE/SEI 7.
2. Concrete base materials: The Hilti fasteners installed in concrete may be used to support distributed systems and distribution systems where the service load on any individual fastener does not exceed the lesser of 90 lbf (400 N) or the allowable load shown in Tables 3, 4 and 5, as applicable.
3. Steel base materials: When the Hilti fasteners listed in Table 2 (except for the X-P 14 G2) are installed in steel base materials and subjected to seismic load, the most critical load applied to each individual fastener must be determined from the equations in Section 2.4 of ASCE 7-16/S1 (referenced in 2021 IBC Section 1605.1) or 2021 IBC Section 1605.2 (2018, 2015 and 2012 IBC Section 1605.3.1 or Section 1605.3.2) which include seismic load effects, and must not exceed the allowable load shown in Table 2. The X-P G2 fasteners may be used for attaching nonstructural components where the service load on any individual fastener does not exceed the lesser of 250 lbf (1112 N) or the published allowable load shown in Table 2.
4. For interior, nonstructural walls that are not subject to sustained tension loads and are not a bracing application, the power-actuated fasteners may be used to attach steel track to concrete or steel in all Seismic Design Categories. In Seismic Design

Categories D, E, and F, the allowable shear load due to transverse pressure must be no more than 90 pounds (400 N) when attaching to concrete; or the allowable load described in Item 3, above, when attaching to steel. Substantiating calculations must be submitted addressing the fastener-to-base-material capacity and the fastener-to-attached-material capacity. Interior nonstructural walls are limited to locations where bearing walls, shear walls or braced walls are not required by the approved plans. The design load on the fastener must not exceed the allowable load established in this report for the concrete or steel base material.

4.2 Installation:

The fasteners must be installed in accordance with this report and the Hilti, Inc. published installation instructions. A copy of these instructions must be available on the jobsite at all times during fastener installation.

Fastener installation requires the use of a low-velocity power-actuated tool (gas, powder or electro-mechanical actuated) in accordance with Hilti, Inc. recommendations. Installers of powder-actuated fasteners must be certified by Hilti, Inc., and have a current, Hilti-issued, operator's license. Installers of gas-driven or electro-mechanical-driven fasteners do not require an operator's license.

The fastener size, minimum embedment depth or penetration, minimum spacing, and edge distances must comply with Tables 2 through 6, as applicable. For fasteners installed into concrete or masonry, the fasteners must not be driven until the concrete or masonry has reached the designated compressive strength.

5.0 CONDITIONS OF USE

The Hilti low-velocity power-actuated fasteners described in this report comply with, or are suitable alternatives to what is specified in, those codes listed in Section 1.0 of this report, subject to the following conditions:

- 5.1 Fasteners must be manufactured and identified in accordance with this report.
- 5.2 Fasteners must be installed in accordance with this report and the Hilti, Inc. instructions. In the event of conflict between this report and the Hilti, Inc. published instructions, the more restrictive requirements govern.
- 5.3 Calculations demonstrating that the applied loads are less than the allowable loads described in this report must be submitted to the code official for approval. The calculations must be prepared by a registered design professional where required by the statutes of the jurisdiction in which the project is constructed.

5.4 For steel-to-steel connections that meet the applicability requirements of Section J5 of AISI S100 (Section E5 of AISI S100-12 for the 2015 and 2012 IBC), calculations demonstrating that the available connection strength has been determined in accordance with Section J5 of AISI S100 (Section E5 of AISI S100-12) and Section 4.1.4 of this report, and equals or exceeds the applied load, must be submitted to the code official. The calculations must be prepared by a registered design professional where required by the statutes of the jurisdiction in which the project is to be constructed.

5.5 Refer to Section 4.1.5 for seismic considerations.

5.6 The fasteners must be limited to dry, interior locations, which include exterior walls which are protected by an exterior wall envelope.

5.7 The use of fasteners in concrete or masonry is limited to installation in uncracked concrete or masonry. Cracking occurs when $f_t > f_r$ due to service loads or deformations.

5.8 The Hilti products addressed in this report are manufactured under a quality-control program with inspections by ICC-ES.

6.0 EVIDENCE SUBMITTED

Data in accordance with the ICC-ES Acceptance Criteria for Power-actuated Fasteners Driven into Concrete, Steel, and Masonry Elements (AC70), dated December 2019 (editorially revised January 2021), including seismic load test data in accordance with Annex A of AC70.

7.0 IDENTIFICATION

7.1 Hilti low-velocity power-actuated fasteners, collated into plastic strips of ten, are identified by an "H" imprinted on the fastener head. All fasteners are packaged in containers that bear the fastener type and size, the report holder's name (Hilti, Inc.), and the evaluation report number (ESR-1752).

7.2 The report holder contact information is the following:

HILTI, INC.
7250 DALLAS PARKWAY, SUITE 1000
PLANO, TEXAS 75024
(800) 879-8000
www.hilti.com
HNATechnicalServices@hilti.com

TABLE 1—FASTENER DESCRIPTION AND APPLICATIONS¹

FASTENER	FASTENER DESCRIPTION	SHANK TYPE	SHANK DIAMETER [inch (mm)]	HEAD DIAMETER [inch (mm)]	MAXIMUM POINT LENGTH [inch (mm)]	MINIMUM EFFECTIVE SHANK LENGTH ² [inch (mm)]	FASTENER COATING	APPLICABLE BASE MATERIAL	APPLICABLE LOAD TABLES
X-C ##	Powder Actuated Standard Fastener (Figure 1)	Knurled, straight	0.138 (3.5)	0.321 (8.15)	0.295 (7.5)	See Footnote 2	ASTM B633, SC1, Type III	Concrete Conc.-filled deck CMU	3, 4, 5, 6
X-C22 P8TH	Powder Actuated Standard Fastener w/ Metal Tophat Washer (Figure 2)	Knurled, straight	0.138 (3.5)	0.321 (8.15)	0.295 (7.5)	0.807 (20.5)	ASTM B633, SC1, Type III	Concrete Conc.-filled deck	3, 4, 5
X-C20 THP	Powder Actuated Standard Fastener w/ Plastic Tophat Washer (Figure 3)	Knurled, straight	0.138 (3.5)	0.321 (8.15)	0.295 (7.5)	0.728 (18.5)	ASTM B633, SC1, Type III	Concrete Conc.-filled deck	4
X-S13 THP	Powder Actuated Steel Fastener w/ Plastic Tophat Washer (Figure 4)	Knurled, straight	0.145 (3.7)	0.321 (8.15)	0.295 (7.5)	0.461 (11.7)	ASTM B633, SC1, Type III	Steel	2
X-S16P8TH	Powder Actuated Steel Fastener w/ Metal Tophat Washer (Figure 2)	Smooth, tapered	0.145 (3.7)	0.323 (8.2)	0.362 (9.2)	0.571 (14.5)	ASTM B633, SC1, Type III	Steel	2
X-GN20	Standard Gas Driven Fastener (Figure 5)	Knurled, straight	0.118 (3.0)	0.268 (6.8)	0.224 (5.7)	0.709 (18.0)	ASTM B633, SC1, Type III	Concrete Conc.-filled deck CMU	3, 4, 5, 6
X-GN27						1.024 (26.0)			
X-GN32						1.220 (31.0)			
X-GN39 X-C 39 G2 X-C 39 G3	Standard Gas Driven Fastener (Figure 6)	Knurled, straight	0.101 (2.6)	0.228 (5.8)	0.224 (5.7)	1.476 (37.5)	ASTM B633, SC1, Type III	Concrete CMU	3, 6
X-EGN14	Standard Gas Driven Fastener for Steel (Figure 7)	Smooth, tapered	0.118 (3.0)	0.268 (6.8)	0.394 (10.0)	0.512 (13.0)	2-to-10-micron Zinc	Steel	2
X-GHP##	Premium Gas Driven Fastener (Figure 8)	Smooth, tapered	0.118 (3.0)	0.268 (6.8)	0.394 (10.0)	See Footnote 2	2-to-10-micron Zinc	Steel Concrete Conc.-filled deck	2, 3, 4, 5
X-C 20 G3	Standard Gas Driven Fastener (Figure 9)	Knurled, straight	0.118 (3.0)	0.256 (6.5)	0.209 (5.3)	0.709	ASTM B633, SC1, Type III	Concrete Conc.-filled deck CMU	3, 4, 5, 6
X-C ## G3 (except for X-C 39 G3)						See Footnote 2			
X-S 14 G3						2-to-10-micron Zinc			
X-P ## G3	Premium Gas Driven Fastener (Figure 10)	Smooth, tapered	0.118 (3.0)	0.268 (6.8)	0.394 (10.0)	See Footnote 2	2-to-10-micron Zinc	Steel Concrete Conc.-filled deck	2, 3, 4, 5
X-C 20 G2 X-C 27 G2 X-C 32 G2	Standard Gas Driven Fastener (Figure 11)	Knurled, straight	0.108 (2.75)	0.248 (6.3)	0.193 (4.9)	0.711 (18.1) 1.039 (26.4) 1.211 (30.8)	2-to-10-micron Zinc	Concrete Conc.-filled deck CMU	3, 4, 5, 6
X-P 14 G2	Premium Gas Driven Fastener (Figure 12)	Knurled, tapered	0.118 (3.0)	0.248 (6.3)	0.189 (4.8)	0.512 (13.0)	8-to-16-micron Zinc	Steel	2
X-P 17 G2 X-P 20 G2	Premium Gas Driven Fastener (Figure 12)	Smooth, tapered	0.118 (3.0)	0.260 (6.6)	0.394 (10.0)	0.630 (16.0) 0.748 (19.0)	2-to-10-micron Zinc	Steel Concrete Conc.-filled deck	2, 3, 4, 5
X-C 20 B3 X-C ## B3 (except for X-C 36 B3)	Electro-mechanical Driven Fastener (Figure 13)	Knurled, straight	0.118 (3.0)	0.256 (6.5)	0.209 (5.3)	0.709 (18.0) See Footnote 2	ASTM B633, SC1, Type III	Concrete Conc.-filled deck CMU	3, 4, 5, 6
X-C 36 B3	Electro-mechanical Driven Fastener (Figure 13)	Knurled, straight	0.108 (2.75)	0.248 (6.3)	0.193 (4.9)	1.378 (35.0)	2-to-10-micron Zinc	Concrete Conc.-filled deck CMU	3, 4, 5, 6
X-S 14 B3	Electro-mechanical Driven Fastener (Figure 14)	Smooth, tapered	0.118 (3.0)	0.268 (6.8)	0.394 (10.0)	0.512 (13.0)	2-to-10-micron Zinc	Steel	2
X-P ## B3	Electro-mechanical Driven Fastener (Figure 14)	Smooth, tapered	0.118 (3.0)	0.268 (6.8)	0.394 (10.0)	See Footnote 2	2-to-10-micron Zinc	Steel Concrete Conc.-filled deck	2, 3, 4, 5

For SI: 1 inch = 25.4 mm.

¹## denotes numbers used in fastener designation to represent nominal fastener length in mm.

²When multiple lengths of a fastener are addressed, the minimum effective shank length can be calculated in terms of the designated length as (##-1) in mm and (##-1)/25.4 in inches.

TABLE 2—ALLOWABLE LOADS FOR FASTENERS DRIVEN INTO STEEL^{1,2,3,4}

FASTENER	SHANK DIAMETER (INCH)	ALLOWABLE LOADS (lbf)											
		¹ / ₈		³ / ₁₆		¹ / ₄		³ / ₈		¹ / ₂		³ / ₄	
Steel Thickness (inch):		Tension	Shear	Tension	Shear	Tension	Shear	Tension	Shear	Tension	Shear	Tension	Shear
X-S13 THP	0.145	140 ¹⁰	300	300 ¹⁰	450	300 ¹⁰	450	300 ¹⁰	450	--	--	--	--
X-S16P8TH	0.145	--	--	225 ¹⁰	420	225 ¹⁰	430	225 ¹⁰	430	225 ¹⁰	430	--	--
X-EGN14 X-S 14 B3 X-S 14 G3	0.118	140	230	220	245	225	290	280 ⁶	330 ⁶	280 ⁶	330 ⁶	280 ⁶	330 ⁶
X-EGN14 ⁵ X-S 14 B3 ⁵ X-S 14 G3 ⁵	0.118	--	--	220	295	260	355	280 ⁶	385 ⁶	280 ⁶	385 ⁶	280 ⁶	385 ⁶
X-GHP## X-P ## G3 X-P ## B3	0.118	125 ¹⁰	230	170 ¹⁰	245	200 ¹⁰	230	250 ¹⁰	255	--	--	--	--
X-P 17 G2 ⁷ X-P 20 G2 ⁷	0.118	--	--	140 ¹⁰	220	180 ⁸	200 ⁸	225 ⁶	220 ⁶	--	--	--	--
X-P 14 G2 ⁷	0.118	--	--	--	--	215 ⁸	290 ⁸	150 ⁹	195 ⁹	130 ⁹	150 ⁹	130 ⁹	150 ⁹

For **S1**: 1 inch = 25.4 mm, 1 ksi = 6.89 MPa, 1 lbf = 4.4 N.

¹Unless otherwise noted, fasteners must be driven to where the full length of the point of the fastener penetrates through the steel base material.

²Unless otherwise noted, steel base material must have minimum yield and tensile strengths (F_y and F_u) equal to 36 ksi and 58 ksi, respectively.

³Unless otherwise noted, allowable loads are applicable to static loads and seismic loads in accordance with Section 4.1.

⁴Fastener spacing must be a minimum of 1.0 inch and edge distance must be a minimum of 0.50 inch.

⁵Steel base material must have minimum yield and tensile strengths (F_y and F_u) equal to 50 ksi and 65 ksi, respectively.

⁶Fastener point penetration through the steel is not necessary, provided a minimum embedment of 0.320 inch is achieved.

⁷Tabulated loads for this fastener apply to static load conditions only. For seismic loading, allowable loads must be limited in accordance with Section 4.1.5, Item 3.

⁸Full fastener point penetration through the steel is not necessary, provided a minimum point penetration of 0.08 inch is achieved.

⁹Fastener point penetration through the steel is not necessary, provided a minimum embedment of 0.25 inch is achieved.

¹⁰For steel-to-steel connections designed in accordance with Section 4.1.4, the tabulated allowable load may be increased by a factor of 1.25, and the design strength may be taken as the tabulated allowable load multiplied by a factor of 2.0.

TABLE 3—ALLOWABLE LOADS FOR FASTENERS DRIVEN INTO NORMALWEIGHT CONCRETE^{1,2,3}

FASTENER	SHANK DIAMETER (inch)	MINIMUM EMBEDMENT DEPTH (inches)	ALLOWABLE LOADS (lbf)					
			2,000 psi		4,000 psi		6,000 psi	
Concrete Compressive Strength:			Tension	Shear	Tension	Shear	Tension	Shear
Load Direction:			Tension	Shear	Tension	Shear	Tension	Shear
X-C ## (Black Collated Strip or Guidance Washer)	0.138	3/4	45	75	65	105	95	195
		1	85	150	160	200	105	270
		1 1/4	130	210	270	290	165	325
		1 1/2	175	260	270	360	--	--
X-C ## (White Collated Strip or Guidance Washer)	0.138	3/4	45	75	60	105	--	--
		1	85	150	90	200	--	--
		1 1/4	130	210	130	290	--	--
X-C22 P8TH (Black Collated Strip or Guidance Washer)	0.138	3/4	55	130	90	170	100	200
X-C22 P8TH (White Collated Strip or Guidance Washer)	0.138	3/4	55	130	90	170	--	--
X-GN (except for X-GN 39)	0.118	3/4	95	120	95	120	--	--
		1	115	220	115	220	--	--
X-GN39 X-C 39 G2 X-C 39 G3	0.101	5/8	50	80	50	80	--	--
		1	60	100	60	100	--	--
X-GHP## X-P 17 G2, X-P 20 G2 X-P ## G3 X-P ## B3	0.118	5/8	--	--	50	120	50	90
		3/4	80	120	--	--	--	--
X-C ## G2 (except for X-C 39 G2) X-C 36 B3	0.108	3/4	110	190	110	190	110	190
X-C ## G3 (except for X-C 39 G3) X-C ## B3 (except for X-C 36 B3)	0.118	3/4	110	190	110	190	110	190

For SI: 1 inch = 25.4 mm, 1 psi = 6.89 kPa, 1 lbf = 4.4 N.

¹Fasteners must not be driven until the concrete has reached the designated minimum compressive strength, or the minimum compressive strength specified in the applicable code, whichever is greater.

²Concrete thickness must be a minimum of 3 times the embedment depth of the fastener. Fastener spacing must be a minimum of 4 inches and edge distance must be a minimum of 3 inches.

³The fasteners listed in the table above may be used for static load conditions and for the seismic load conditions described in Section 4.1.5, as applicable. The tabulated allowable loads apply to static load conditions. For seismic load conditions, the allowable loads must be limited in accordance with Section 4.1.5, Items 2 and 4, as applicable.

TABLE 4—ALLOWABLE LOADS FOR FASTENERS DRIVEN INTO MINIMUM 3,000 psi LIGHTWEIGHT CONCRETE AND LIGHTWEIGHT CONCRETE OVER 3-INCH-DEEP, COMPOSITE STEEL DECK PANELS ^{1,2,3}

FASTENER	SHANK DIAMETER (inch)	MINIMUM EMBEDMENT DEPTH (inches)	ALLOWABLE LOADS (lbf)						Minimum Required Concrete Thickness Above Deck Panel (inches)
			Fasteners Installed Directly into Concrete		Fasteners Installed Through Steel Deck Panel into Concrete ⁴				
					Upper Flute	Lower Flute	Upper Flute	Lower Flute	
Fastener Location:			Tension	Shear	Tension		Shear		
Load Direction:			Tension	Shear	Tension		Shear		
X-C ## (Black Collated Strip or Guidance Washer)	0.138	3/4	120	175	120	95	265	265	3 1/4
		1	180	260	215	155	485	485	3 1/4
		1 1/4	225	400	250	200	500	500	3 1/4
		1 1/2	285	400	285	210	555	555	3 1/4
X-C ## (White Collated Strip or Guidance Washer)	0.138	3/4	110	175	120	--	265	265	3 1/4
		1	135	180	215	145	485	485	3 1/4
		1 1/4	220	260	250	200	500	500	3 1/4
X-C22 P8TH (Black Collated Strip or Guidance Washer)	0.138	3/4	120	220	120	95	260	260	3 1/4
X-C22 P8TH (White Collated Strip or Guidance Washer)	0.138	3/4	110	220	120	60	260	260	3 1/4
X-C20 THP	0.138	3/4	55	110	--	45	285	285	3 1/4
X-GN ## (except for X-GN 39) X-C ## G3 (except for X-C 39 G3) X-C ## B3 (except for X-C 36 B3)	0.118	3/4	115	140	75	85	175	215	2 1/2
		1	170	220	155	160	255	315	3 1/4
X-GHP## X-P 17 G2 X-P 20 G2 X-P ## G3 X-P ## B3	0.118	5/8	60	140	60	60	175	215	2 1/2
X-C ## G2 (except for X-C 39 G2) X-C 36 B3	0.108	3/4	110	140	75	85	175	215	2 1/2
		1	170	220	155	160	255	315	3

For SI: 1 inch = 25.4 mm, 1 psi = 6.89 kPa, 1 lbf = 4.4 N.

¹Fasteners must not be driven until the concrete has reached a minimum compressive strength of 3,000 psi.

²Unless otherwise noted, concrete thickness must be a minimum of 3 times the embedment depth of the fastener, fastener spacing must be a minimum of 4 inches and edge distance must be a minimum of 3 inches.

³The fasteners listed in the table above may be used for static load conditions and for the seismic load conditions described in Section 4.1.5, as applicable. The tabulated allowable loads apply to static load conditions. For seismic load conditions, the allowable loads must be limited in accordance with Section 4.1.5, Items 3 and 4, as applicable.

⁴Steel deck panel must be 3-inch-deep composite floor deck panel, minimum No. 20 gage (0.0359-inch-thick base steel thickness), with a minimum yield strength of 40 ksi and a minimum tensile strength of 55 ksi. The thickness of sand-lightweight concrete fill above top of metal deck panel profiles must be as shown in the table. See Figure 15 for nominal flute dimensions, fastener locations, and load orientations.

TABLE 5—ALLOWABLE LOADS FOR FASTENERS DRIVEN INTO MINIMUM 3,000 psi SAND-LIGHTWEIGHT CONCRETE OVER 1 1/2-INCH-DEEP, B-DECK STEEL PANEL^{1,2,3}

FASTENER	SHANK DIAMETER (inch)	MINIMUM EMBEDMENT DEPTH (inches)	ALLOWABLE LOADS (lbf)				Minimum Required Concrete Thickness Above Deck Panel (inches)
			Fasteners Installed Through Steel Deck Panel into Concrete ⁴				
Fastener Location:			Upper Flute	Lower Flute	Upper Flute	Lower Flute	
Load Direction:			Tension		Shear		
X-C ## ⁵	0.138	3/4	80	80	315	315	2 1/2
		1	205	205	445	445	2 1/2
X-C22 P8TH ⁵	0.138	3/4	90	110	295	295	2 1/2
X-GN ## (except for X-GN 39) X-C ## G3 (except for X-C 39 G3) X-C ## B3	0.118	3/4	75	85	175	215	2 1/2
		1	155	160	255	315	3 1/4
X-GHP## X-P 17 G2 X-P 20 G2 X-P ## G3 X-P ## B3	0.118	5/8	60	60	175	215	2 1/2
X-C ## G2 (except for X-C 39 G2) X-C 36 B3	0.108	3/4	75	85	175	215	2 1/2
		1	155	160	255	270	3 1/4

For SI: 1 inch = 25.4 mm, 1 psi = 6.89 kPa, 1 lbf = 4.4 N.

¹Fasteners must not be driven until the concrete has reached a minimum compressive strength of 3,000 psi.

²Unless otherwise noted, concrete thickness must be a minimum of 3 times the embedment depth of the fastener, fastener spacing must be a minimum of 4 inches and edge distance must be a minimum of 3 inches.

³The fasteners listed in the table above may be used for static load conditions and for the seismic load conditions described in Section 4.1.5, as applicable. The tabulated allowable loads apply to static load conditions. For seismic load conditions, the allowable loads must be limited in accordance with Section 4.1.5, Items 3 and 4, as applicable.

⁴Steel deck panel must be 1 1/2-inch-deep, B-type deck panel, minimum No. 20 gage (0.0359-inch-thick base steel thickness), with a minimum yield strength of 40 ksi and a minimum tensile strength of 55 ksi. The thickness of sand-lightweight concrete fill above top of metal deck panel profiles must be as shown in the table. Fasteners may be installed through steel deck panels having either normal and inverted orientations. Fasteners must be placed at centerline of deck panel flutes. See Figures 16 and 17 for nominal flute dimensions, fastener locations, and load orientations.

⁵Allowable load values apply to fasteners with black or white collated strip or guidance washer.

TABLE 6—ALLOWABLE LOADS FOR FASTENERS DRIVEN INTO CONCRETE MASONRY ^{1,2,9,11}

FASTENER	SHANK DIAMETER (inch)	MINIMUM EMBEDMENT DEPTH (inch)	CMU TYPE, MORTAR TYPE	ALLOWABLE LOADS (lbf)									
				Hollow CMU				Grouted CMU					
Masonry Type:				Hollow CMU				Grouted CMU					
Fastener Location:				Face Shell ³		Mortar Joint		Face Shell ³		Mortar Joint		Top of Grouted Cell ⁸	
Load Direction:				Tension	Shear ⁴	Tension	Shear	Tension	Shear ⁴	Tension	Shear	Tension	Shear ⁴
X-C ## ¹⁰	0.138	3/4	Normal weight, Type N minimum	40	85	20	85 ⁵	85	85	105	105 ⁵	--	--
		1		--	--	--	--	--	--	--	180	275	
X-GN ## (except for X-GN 39) X-C ## G3 (except for X-C 39 G3) X-C ## B3	0.118	3/4	Normal weight, Type N minimum	145	190	80	80 ⁶	155	195	110	135 ⁶	105	145
		1		185	205	105	105 ⁶	205	215	135	190 ⁶	120	150
X-GN39 X-C 39 G2 X-C 39 G3	0.101	5/8	Normal weight, Type S minimum	60	110	45	65 ⁷	85	110	55	105 ⁷	--	--
X-C ## G2 (except for X-C 39 G2) X-C 36 B3	0.108	3/4	Normal weight, Type S minimum	75	140	60	80 ⁷	100	170	100	160 ⁷	80	130
		1		110	190	70	145 ⁷	135	195	125	165 ⁷	110	145

For SI: 1 lbf = 4.4 N, 1 inch = 25.4 mm.

¹See Section 3.2.2 for additional CMU, mortar and grout requirements.

²No more than one fastener may be installed in an individual masonry unit cell.

³See Figure 18 for the applicable placement zone.

⁴Shear can be applied in any direction.

⁵Applies to installation in horizontal bed joint with shear load applied parallel to the bed joint. Fastener spacing must be a minimum of 4 inches.

⁶Shear direction can be horizontal or vertical (bed joint or head joint) along the CMU wall plane.

⁷Applies to installation in horizontal bed joint with shear load applied perpendicular to the bed joint. Fastener spacing must be a minimum of 4 inches.

⁸Fastener located in center of grouted cell, installed vertically.

⁹Fasteners must be installed a minimum of 8 inches from the end of the wall. Unless otherwise noted, multiple fasteners in a bed joint must be spaced a minimum of 8 inches.

¹⁰Allowable load values apply to fasteners with black or white collated strip or guidance washer.

¹¹The fasteners listed in the table above may be used for static load conditions and for the seismic load conditions described in Item 1 of Section 4.1.5.



FIGURE 1—HILTI X-C ## FASTENER

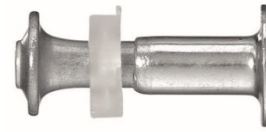

FIGURE 2—HILTI X-C22 P8TH/X-S16 P8TH FASTENER



FIGURE 3—HILTI X-C20 THP FASTENER



FIGURE 4—HILTI X-S13 THP FASTENER



FIGURE 5—HILTI X-GN## FASTENER
(Except X-GN39)



FIGURE 6—HILTI X-GN39 FASTENER
(X-C 39 G2 and X-C 39 G3 similar)



FIGURE 7—HILTI X-EGN14 FASTENER



FIGURE 8—HILTI X-GHP## FASTENER



FIGURE 9—HILTI X-C ## G3 FASTENER
(Except X-C 39 G3)



FIGURE 10—HILTI X-S 14 G3/X-P G3 FASTENER



FIGURE 11—HILTI X-C ## G2 FASTENER



FIGURE 12—HILTI X-P 14 G2 FASTENER
(X-P ## G2 similar)



FIGURE 13—HILTI X-C ## B3 FASTENER
(X-C 36 B3 similar)



FIGURE 14—HILTI X-S 14 B3/X-P ## B3 FASTENER

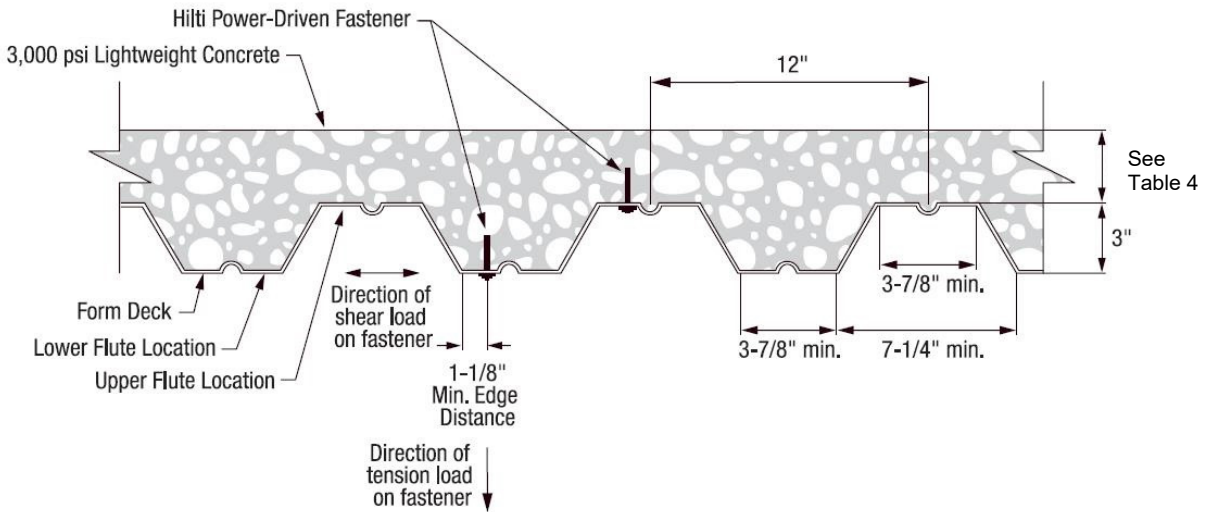

FIGURE 15—HILTI FASTENER LOCATIONS IN 3-INCH-DEEP COMPOSITE FLOOR DECK PANEL

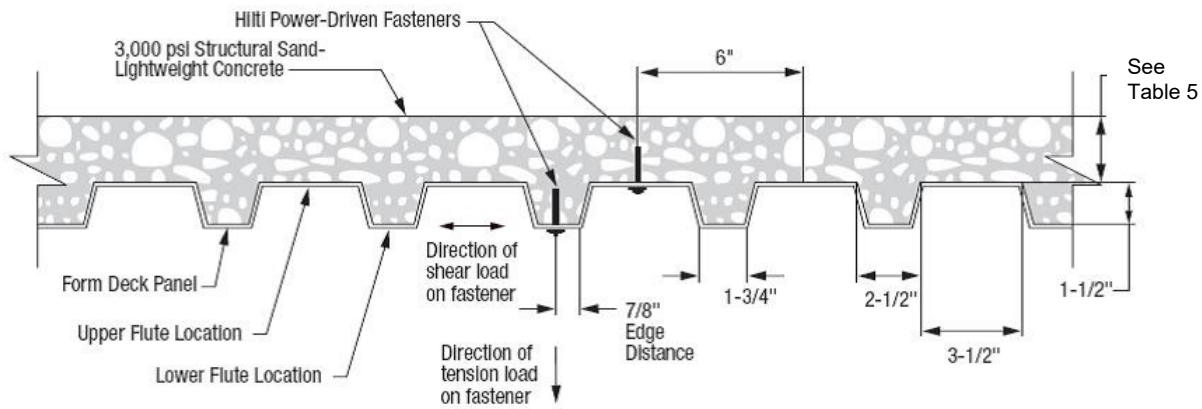
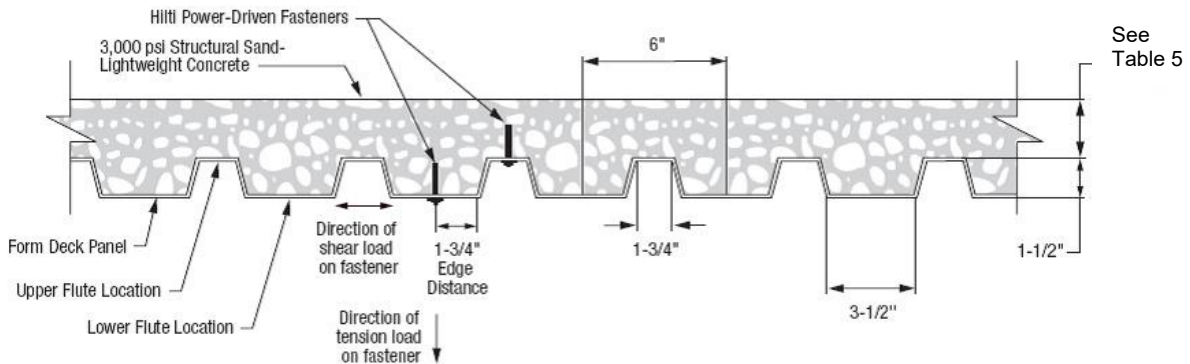

FIGURE 16—HILTI FASTENER LOCATIONS IN 1 1/2-INCH-DEEP COMPOSITE FLOOR DECK PANEL



For SI: 1 inch = 25.4 mm, 1 psi = 6895 Pa.

FIGURE 17—HILTI FASTENER LOCATIONS IN 1 1/2-INCH-DEEP COMPOSITE FLOOR DECK PANEL, INVERTED DECK PANEL PROFILE ORIENTATION

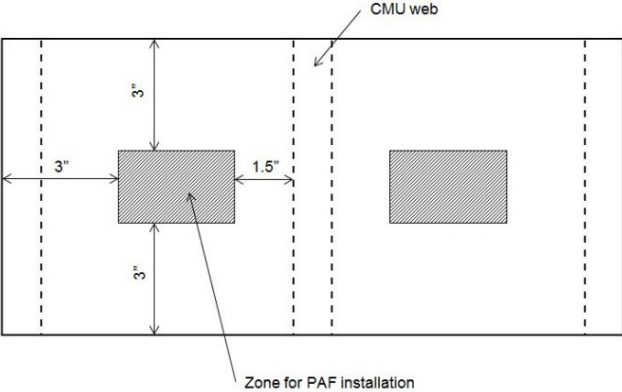

FIGURE 18—ZONE FOR FASTENER INSTALLATION IN FACE SHELL OF CMU

DIVISION: 03 00 00—CONCRETE
Section: 03 15 00—Concrete Accessories
Section: 03 16 00—Concrete Anchors

DIVISION: 04 00 00—MASONRY
Section: 04 05 19.16—Masonry Anchors

DIVISION: 05 00 00—METALS
Section: 05 05 23—Metal Fastenings

DIVISION: 09 00 00—FINISHES
Section: 09 22 16.23—Fasteners

REPORT HOLDER:

HILTI, INC.

EVALUATION SUBJECT:

HILTI LOW-VELOCITY POWER-ACTUATED FASTENERS

1.0 REPORT PURPOSE AND SCOPE**Purpose:**

The purpose of this evaluation report supplement is to indicate that Hilti low-velocity power-actuated fasteners, described in ICC-ES evaluation report [ESR-1752](#), have also been evaluated for compliance with the codes noted below as adopted by the Los Angeles Department of Building and Safety (LADBS).

Applicable code editions:

- 2020 *City of Los Angeles Building Code* (LABC)
- 2020 *City of Los Angeles Residential Code* (LARC)

2.0 CONCLUSIONS

The Hilti low-velocity power-actuated fasteners, described in Sections 2.0 through 7.0 of the evaluation report [ESR-1752](#), comply with LABC Chapters 19, 21 and 22, and the LARC, and are subjected to the conditions of use described in this supplement.

3.0 CONDITIONS OF USE

The Hilti low-velocity power-actuated fasteners described in this evaluation report supplement must comply with all of the following conditions:

- All applicable sections in the evaluation report [ESR-1752](#).
- The design, installation, conditions of use and identification of the fasteners are in accordance with the 2018 *International Building Code*® (2018 IBC) provisions noted in the evaluation report [ESR-1752](#).
- The design, installation and inspection are in accordance with additional requirements of LABC Chapters 16 and 17, as applicable.
- Under the LARC, an engineered design in accordance with LARC Section R301.1.3 must be submitted.
- The allowable load and strength design values listed in the evaluation report and tables are for the connection of the fasteners to steel, normalweight concrete, lightweight and sand-lightweight concrete over metal decks, and masonry. The connection between the fasteners and the connected members shall be checked for capacity (which may govern).

This supplement expires concurrently with the evaluation report, reissued September 2021.

DIVISION: 03 00 00—CONCRETE

Section: 03 15 00—Concrete Accessories

Section: 03 16 00—Concrete Anchors

DIVISION: 04 00 00—MASONRY

Section: 04 05 19.16—Masonry Anchors

DIVISION: 05 00 00—METALS

Section: 05 05 23—Metal Fastenings

DIVISION: 09 00 00—FINISHES

Section: 09 22 16.23—Fasteners

REPORT HOLDER:

HILTI, INC.

EVALUATION SUBJECT:

HILTI LOW-VELOCITY POWER-ACTUATED FASTENERS

1.0 REPORT PURPOSE AND SCOPE**Purpose:**

The purpose of this evaluation report supplement is to indicate that the Hilti Low-velocity Power-actuated Fasteners, described in ICC-ES evaluation report ESR-1752, have also been evaluated for compliance with the codes noted below.

Applicable code editions:

- 2020 *Florida Building Code—Building*
- 2020 *Florida Building Code—Residential*

2.0 CONCLUSIONS

The Hilti Low-velocity Power-actuated Fasteners, described in Sections 2.0 through 7.0 of the evaluation report ESR-1752, comply with the *Florida Building Code—Building* and the *Florida Building Code—Residential*, provided the design and installation are in accordance with the 2018 *International Building Code*® provisions noted in the evaluation report.

Use of the Hilti fasteners has also been found to be in compliance with the High-Velocity Hurricane Zone provisions of the *Florida Building Code—Building* and the *Florida Building Code—Residential*.

For products falling under Florida Rule 61G20-3, verification that the report holder's quality-assurance program is audited by a quality-assurance entity approved by the Florida Building Commission for the type of inspections being conducted is the responsibility of an approved validation entity (or the code official, when the report holder does not possess an approval by the Commission).

This supplement expires concurrently with the evaluation report, reissued September 2021.