

Chemical Anchor EASF



Product description

EASF is two component bonded anchoring system anchoring of wide variety of construction applications. Since it is formulated free of styrene and vinyl toluene(VT), EASF has almost no odour and is ideal for indoor and outdoor applications.

EASF is for heavy-duty applications in non-cracked concrete and masonry and many other base materials like aerated concrete, lightweight solid or hollow concrete blocks or sand lime bricks. EASF chemical anchor can be used for post-installed rebar connections Ø8 to Ø32. EASF has three version for various climate conditions.

- EASF: Normal working and loading time
- EASF-A: Faster working and loading time for arctic(up to -20 °C) climate
- EASF-E: Slower working and loading time for hot climate

Main constituent	:	Epoxy acrylate resin
Appearance (uncured)	:	Paste
Colour	:	Grey
Viscosity	:	Thixotropic, high

Applications:

Masonry support, Handrails, Fences, balcony parapets, road signs, Pipe systems, lighting systems, canopies, safety barriers, racking, machinery, ventilation systems, reinforcement bar systems.

Features:

- Assessed for structural applications in cracked and non-cracked concrete, M8 to M30. Rebar used as stud from Ø8 to Ø32 Working life of 50 and/or 100 years.
- Dry, wet and flooded holes
- Temperature range: from -40°C to +80°C (long term maximum temperature +50°C).
- For high loads
- Styrene free formulation (SF)
- Compatible with several building materials including perforated brick.
- For heavy anchoring - doweling and post-installed rebar connection
- Low odour and VOC content (A+)
- Seismic anchor performance category (C1)

Chemical Anchor EASF



Working and loading time

Working time is typical gel time at the highest temperature of the given range.

Loading time is setting time at the lowest temperature of the given range.

Epoxyacrylate Styrene Free (EASF)

Temperature of base material	+5°C	+5°C to +10°C	+10°C to +20°C	+20°C to +25°C	+25°C to +30°C	+30°C
Temperature of cartridge	+5°C	+5°C to +10°C	+10°C to +20°C	+20°C to +25°C	+25°C to +30°C	+30°C
Working time (mins)	18	10	6	5	4	3
Loading time (mins)	150	150	85	50	40	35

Epoxyacrylate Styrene Free Arctic Grade (EASF-A)

Temperature of base material	-20°C	-20°C to -10°C	-10°C to 0°C	0°C to +5°C	+5°C to +15°C	+15°C
Temperature of cartridge	-20°C	-20°C to -10°C	-10°C to 0°C	0°C to +5°C	+5°C to +15°C	+15°C
Working time (mins)	60	45	20	6	3	2
Loading time (mins)	24hr	960	360	240	75	45

Epoxyacrylate Styrene Free Tropical Grade (EASF-E)

Temperature of base material	+10°C	+10°C to +20°C	+20°C to +25°C	+25°C to +30°C	+30°C to +35°C	+35°C to +40°C	+40°C to +45°C	+45°C
Temperature of cartridge	+10°C	+10°C to +20°C	+20°C to +25°C	+25°C to +30°C	+30°C to +35°C	+35°C to +40°C	+40°C to +45°C	+45°C
Working time (mins)	30	15	10	7.5	5	3.5	2.5	1.5
Loading time (mins)	300	300	150	85	50	40	35	15

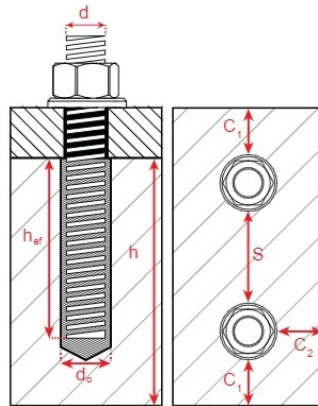

Installation parameter - Threaded Rod

Anchor size		M8	M10	M12	M16	M20	M24	M27	M30	
d	Diameter of anchor bolt or thread diameter	mm	8	10	12	16	20	24	27	30
d ₀	Nominal diameter of drill bit	mm	10	12	14	18	24	28	32	35
d _f	Diameter of clearance hole in the fixture (≤)	mm	9	12	14	18	22	26	30	33
d _b	Diameter of steel brush (≥)	mm	12	14	16	20	26	30	34	37
h _{ef,min}	Minimum effective anchorage depth	mm	60	60	70	80	90	96	108	120
h _{ef}	Standard effective anchorage depth	mm	80	90	110	125	170	210	250	280
h _{ef,max}	Maximum effective anchorage depth (20*d)	mm	160	200	240	320	400	480	540	600
h _{min}	Minimum thickness of the concrete member	mm	h _{ef} +30mm ≥100mm			h _{ef} + 2d ₀				
T _{Inst}	Nominal torque moment	Nm	10	20	40	80	120	160	180	200
s _{min}	Minimum spacing (5*d)	mm	40	50	60	80	100	120	135	150
s _{cr,N}	Spacing	mm	184	252	304	376	506	582	624	658
c _{min}	Minimum edge distance (5*d)	mm	40	50	60	80	100	120	135	150
c _{cr,N}	Edge distance	mm	92	126	152	188	253	291	312	329

Installation parameter - Reinforcing bar

Anchor size		Ø8	Ø10	Ø12	Ø14	Ø16	Ø20	Ø25	Ø28	Ø32	
d	Diameter of anchor	mm	8	10	12	14	16	20	25	28	32
d ₀	Nominal diameter of drill bit	mm	12	14	16	18	20	24	32	35	40
d _b	Diameter of steel brush (≥)	mm	14	16	18	20	22	26	34	37	41
h _{ef,min}	Minimum effective anchorage depth	mm	60	60	70	75	80	90	100	112	128
h _{ef}	Standard effective anchorage depth	mm	80	90	110	115	125	170	210	250	280
h _{ef,max}	Maximum effective anchorage depth (20*d)	mm	160	200	240	280	320	400	500	560	640

Chemical Anchor EASF

h_{min}	Minimum thickness of the concrete member	mm	$h_{ef}+30mm$ $\geq 100mm$		$h_{ef} + 2d_o$						
S_{min}	Minimum spacing (5*d)	mm	40	50	60	70	80	100	125	140	160
$S_{cr,N}$	Spacing	mm	184	252	304	346	376	506	606	646	682
C_{min}	Minimum edge distance (5*d)	mm	40	50	60	70	80	100	125	140	160
$C_{cr,N}$	Edge distance	mm	92	126	152	173	188	253	303	323	341



Load values – Characteristic Resistance – Threaded bar

Characteristic resistances for C20/25 concrete for an isolated anchor (without considering anchor-to-anchor or anchor-to-edge distance effects) and class 5.8,8.8,10.9 studs or A4-70 and A4-80, 1,4529 stainless steel are shown in tables below.

Characteristic resistance values to tension load – threaded rod

Steel Failure - Characteristic resistance

Size			M8	M10	M12	M16	M20	M24	M27	M30
Steel grade 5.8	$N_{Rk,S}$	[kN]	18	29	42	79	123	177	230	281
Partial safety factor	γ_{Ms}	[-]	1,5							
Steel grade 8.8	$N_{Rk,S}$	[kN]	29	46	67	126	196	282	367	449
Partial safety factor	γ_{Ms}	[-]	1,5							
Steel grade 10.9	$N_{Rk,S}$	[kN]	37	58	84	157	245	353	459	561
Partial safety factor	γ_{Ms}	[-]	1,4							
Stainless Steel grade A4-70	$N_{Rk,S}$	[kN]	26	41	59	110	172	247	321	393
Partial safety factor	γ_{Ms}	[-]	1,9							
Stainless Steel grade A4-80	$N_{Rk,S}$	[kN]	29	46	67	126	196	282	367	449
Partial safety factor	γ_{Ms}	[-]	1,6							
Stainless Steel grade 1,4529	$N_{Rk,S}$	[kN]	26	41	59	110	172	247	321	393
Partial safety factor	γ_{Ms}	[-]	1,5							

Characteristic resistance values to shear load – threaded rod

Steel Failure - Without Lever Arm

Size			M8	M10	M12	M16	M20	M24	M27	M30
Steel grade 5.8	$V_{Rk,S}$	[kN]	9	15	21	39	61	88	115	140
Partial safety factor	γ_{Ms}	[-]	1,25							
Steel grade 8.8	$V_{Rk,S}$	[kN]	15	23	34	63	98	141	184	224
Partial safety factor	γ_{Ms}	[-]	1,25							
Steel grade 10.9	$V_{Rk,S}$	[kN]	18	29	42	79	123	177	230	281

TDS

Chemical Anchor EASF

Partial safety factor	γ_{Ms}	[-]	1,5							
Stainless Steel grade A4-70	$V_{Rk,s}$	[kN]	13	20	30	55	86	124	161	196
Partial safety factor	γ_{Ms}	[-]	1,56							
Stainless Steel grade A4-80	$V_{Rk,s}$	[kN]	15	23	34	63	98	141	184	224
Partial safety factor	γ_{Ms}	[-]	1,33							
Stainless Steel grade 1,4529	$V_{Rk,s}$	[kN]	13	20	30	55	86	124	161	196
Partial safety factor	γ_{Ms}	[-]	1,25							
Steel Failure - With Lever Arm										
Size			M8	M10	M12	M16	M20	M24	M27	M30
Steel grade 5.8	$M^0_{Rk,s}$	[kN]	19	37	66	166	325	561	832	1125
Partial safety factor	γ_{Ms}	[-]	1,25							
Steel grade 8.8	$M^a_{Rk,s}$	[kN]	30	60	105	266	519	898	1332	1799
Partial safety factor	γ_{Ms}	[-]	1,25							
Steel grade 10.9	$M^0_{Rk,s}$	[kN]	37	75	131	333	649	1123	1664	2249
Partial safety factor	γ_{Ms}	[-]	1,5							
Stainless Steel grade A4-70	$M^0_{Rk,s}$	[kN]	26	52	92	233	454	786	1165	1574
Partial safety factor	γ_{Ms}	[-]	1,56							
Stainless Steel grade A4-80	$M^0_{Rk,s}$	[kN]	30	60	105	266	519	898	1332	1799
Partial safety factor	γ_{Ms}	[-]	1,33							
Stainless Steel grade 1,4529	$M^a_{Rk,s}$	[kN]	26	52	92	233	454	786	1165	1574
Partial safety factor	γ_{Ms}	[-]	1,25							
Concrete pry-out failure										
Factor for resistance to pry-out failure	k_3	[-]	2,0							
Installation safety factor	$\gamma_2 = \gamma_{inst}$	[-]	1,0							
Concrete edge failure – threaded bar										
Size			M8	M10	M12	M16	M20	M24	M27	M30
Outside diameter of anchor	d_{nom}	[mm]	8	10	12	16	20	24	27	30
Effective length of anchor	l_f	[mm]	min (h_{ef} , $8 \cdot d_{nom}$)							
Installation safety factor	$\gamma_2 = \gamma_{inst}$	[-]	1,00							

Chemical Anchor EASF

Characteristic resistance to tension load – threaded rod ⁽¹⁾

Characteristic bond resistance in non-cracked concrete C20/25

Concrete Class	Temperature Range ⁽²⁾	Embedment depth	Size		M8	M10	M12	M16	M20	M24	M27	M30
			$N_{Rk,p}$	[kN]								
NON-CRACKED CONCRETE	24 °C / 40 °C	$h_{ef,min}$	$N_{Rk,p}$	[kN]	15,1	22,6	31,7	48,3	62,2	79,6	91,6	101,8
		$h_{ef,standard}$	$N_{Rk,p}$	[kN]	20,1	33,9	49,8	75,4	117,5	174,2	212,1	237,5
		$h_{ef,max} = 20*d$	$N_{Rk,p}$	[kN]	40,2	75,4	108,6	193,0	276,5	398,1	458,0	508,9
	50 °C / 80 °C	$h_{ef,min}$	$N_{Rk,p}$	[kN]	11,3	16,0	22,4	34,2	48,1	61,5	64,1	73,5
		$h_{ef,standard}$	$N_{Rk,p}$	[kN]	15,1	24,0	35,2	53,4	90,8	134,6	148,4	171,5
		$h_{ef,max} = 20*d$	$N_{Rk,p}$	[kN]	30,2	53,4	76,9	136,7	213,6	307,6	320,6	367,6
CRACKED CONCRETE	24 °C / 40 °C	$h_{ef,min}$	$N_{Rk,p}$	[kN]	7,8	9,8	14,0	21,3	30,0	39,8	57,7	73,5
		$h_{ef,standard}$	$N_{Rk,p}$	[kN]	10,5	14,7	22,0	33,3	56,6	87,1	133,6	171,5
		$h_{ef,max} = 20*d$	$N_{Rk,p}$	[kN]	20,9	32,7	48,0	85,3	133,2	199,1	288,6	367,6
	50 °C / 80 °C	$h_{ef,min}$	$N_{Rk,p}$	[kN]	5,5	6,9	9,8	14,9	21,0	27,9	40,4	51,5
		$h_{ef,standard}$	$N_{Rk,p}$	[kN]	7,3	10,3	15,4	23,3	39,6	61,0	93,5	120,1
		$h_{ef,max} = 20*d$	$N_{Rk,p}$	[kN]	14,6	22,9	33,6	59,7	93,2	139,3	202,0	257,3

(1) For more detailed load information, please Declaration of Performance(DOP).

(2) Short term temperature / long term temperature. Long term concrete temperatures are roughly constant over significant periods of time. Short term elevated temperatures are those that occur over brief intervals, e.g. as a result of diurnal cycling.



Load values – Characteristic Resistance – Rebar

Characteristic resistance values to tension load - rebar

Steel Failure - Characteristic resistance

Size			Ø8	Ø10	Ø12	Ø14	Ø16	Ø20	Ø25	Ø28	Ø32
Rebar Grade BSt 500 S	$V_{Rk,s}$	[kN]	28	43	62	85	111	173	270	339	442
Partial safety factor	γ_{Ms}	[-]	1,5								

Characteristic resistance values to shear load - rebar

Steel Failure - Without Lever Arm

Size	Ø8	Ø10	Ø12	Ø14	Ø16	Ø20	Ø25	Ø28	Ø32
------	----	-----	-----	-----	-----	-----	-----	-----	-----

Chemical Anchor EASF

Rebar Grade BSt 500 S	$V_{Rk,s}$	[kN]	14	22	31	42	55	86	135	169	221
Partial safety factor	γ_{Ms}	[-]	1,5								
Ductility factor acc. to CEN/TS 1992-4-5 6.3.2.1	k_2	[-]	0,8								

Steel Failure - With Lever Arm

Size			Ø8	Ø10	Ø12	Ø14	Ø16	Ø20	Ø25	Ø28	Ø32
Rebar Grade BSt 500 S	$M^0_{Rk,s}$	[kN]	33	65	112	178	265	518	1013	1422	2122
Concrete pry-out failure											
Factor for resistance to pry-out failure	k_3	[-]	2,0								
Installation safety factor	$\gamma_2 = \gamma_{inst}$	[-]	1,0								

Concrete edge failure - rebar

Size			Ø8	Ø10	Ø12	Ø14	Ø16	Ø20	Ø25	Ø28	Ø32
Outside diameter of anchor	d_{nom}	[mm]	8	10	12	14	16	20	25	28	32
Effective length of anchor	l_f	[mm]	min (h_{ef} , $8 \cdot d_{nom}$)								
Installation safety factor	$\gamma_2 = \gamma_{inst}$	[-]	1,00								

Characteristic resistance to tension load – rebar ⁽¹⁾

Characteristic bond resistance in non-cracked concrete C20/25

Concrete Class	Temperature Range ⁽²⁾	Embedment depth	Size	Ø8	Ø10	Ø12	Ø14	Ø16	Ø20	Ø25	Ø28	Ø32
NON-CRACKED CONCRETE	24 °C / 40 °C	$h_{ef,min}$	$N_{Rk,p}$ [kN]	15,1	22,6	31,7	39,6	46,2	62,2	78,5	98,5	109,4
		$h_{ef,standard}$	$N_{Rk,p}$ [kN]	20,1	33,9	49,8	60,7	72,3	117,5	164,9	219,9	239,3
		$h_{ef,max} = 20 \cdot d$	$N_{Rk,p}$ [kN]	40,2	75,4	108,6	147,8	185,0	276,5	392,7	492,6	546,9
	50 °C / 80 °C	$h_{ef,min}$	$N_{Rk,p}$ [kN]	10,9	16,3	22,8	28,5	33,3	44,8	56,5	67,0	74,4
		$h_{ef,standard}$	$N_{Rk,p}$ [kN]	14,5	24,4	35,8	43,7	52,0	84,6	118,8	149,5	162,7
		$h_{ef,max} = 20 \cdot d$	$N_{Rk,p}$ [kN]	29,0	54,3	78,2	106,4	133,2	199,1	282,7	335,0	371,9
CRACKED CONCRETE	24 °C / 40 °C	$h_{ef,min}$	$N_{Rk,p}$ [kN]	7,8	9,8	14,0	17,5	21,3	31,1	49,5	64,0	83,6
		$h_{ef,standard}$	$N_{Rk,p}$ [kN]	10,5	14,7	22,0	26,8	33,3	58,7	103,9	142,9	183,0
		$h_{ef,max} = 20 \cdot d$	$N_{Rk,p}$ [kN]	20,9	32,7	48,0	65,3	85,3	138,2	247,4	320,2	418,2
	50 °C / 80 °C	$h_{ef,min}$	$N_{Rk,p}$ [kN]	5,5	6,9	9,8	12,2	14,9	21,8	34,6	44,8	58,5
		$h_{ef,standard}$	$N_{Rk,p}$ [kN]	7,3	10,3	15,4	18,8	23,3	41,1	72,7	100,1	128,1
		$h_{ef,max} = 20 \cdot d$	$N_{Rk,p}$ [kN]	14,6	22,9	33,6	45,7	59,7	96,8	173,2	224,1	292,7

(1) For more detailed load information, please Declaration of Performance(DOP).

Chemical Anchor EASF

- (2) Short term temperature / long term temperature. Long term concrete temperatures are roughly constant over significant periods of time. Short term elevated temperatures are those that occur over brief intervals, e.g. as a result of diurnal cycling.



Load values – Design Resistance – Threaded bar

Design resistance values to tension load - threaded bar

Steel Failure - Design resistance

Size			M8	M10	M12	M16	M20	M24	M27	M30
Steel grade 5.8	$N_{Rd,s}$	[kN]	12	19	28	53	82	118	153	187
Steel grade 8.8	$N_{Rd,s}$	[kN]	19	31	45	84	131	188	245	299
Steel grade 10.9	$N_{Rd,s}$	[kN]	26	41	60	112	175	252	328	401
Stainless Steel grade A4-70	$N_{Rd,s}$	[kN]	14	22	31	58	91	130	169	207
Stainless Steel grade A4-80	$N_{Rd,s}$	[kN]	18	29	42	79	123	176	229	281
Stainless Steel grade 1,4529	$N_{Rd,s}$	[kN]	17	27	39	73	115	165	214	262

Design resistance values to shear load - threaded bar

Steel Failure - Design resistance

Size			M8	M10	M12	M16	M20	M24	M27	M30
Steel grade 5.8	$V_{Rd,s}$	[kN]	7	12	17	31	49	70	92	112
Steel grade 8.8	$V_{Rd,s}$	[kN]	12	18	27	50	78	113	147	179
Steel grade 10.9	$V_{Rd,s}$	[kN]	12	19	28	53	82	118	153	187
Stainless Steel grade A4-70	$V_{Rd,s}$	[kN]	8	13	19	35	55	79	103	126
Stainless Steel grade A4-80	$V_{Rd,s}$	[kN]	11	17	26	47	74	106	138	168
Stainless Steel grade 1,4529	$V_{Rd,s}$	[kN]	10	16	24	44	69	99	129	157

Design resistance values to tension load - threaded bar ⁽¹⁾

Design bond resistance in non-cracked concrete C20/25

Concrete Class	Temperature Range ⁽²⁾	Embedment depth	Size	M8	M10	M12	M16	M20	M24	M27	M30
NON-CRACKED CONCRETE	24 °C / 40 °C	$h_{ef,min}$	$N_{Rd,p}$ [kN]	10,1	12,6	17,6	26,8	34,6	44,2	50,9	56,5
		$h_{ef,standard}$	$N_{Rd,p}$ [kN]	13,4	18,8	27,6	41,9	65,3	96,8	117,8	131,9
		$h_{ef,max} = 20*d$	$N_{Rd,p}$ [kN]	26,8	41,9	60,3	107,2	153,6	221,2	254,5	282,7
	50 °C / 80 °C	$h_{ef,min}$	$N_{Rd,p}$ [kN]	7,5	8,9	12,5	19,0	26,7	34,2	35,6	40,8
		$h_{ef,standard}$	$N_{Rd,p}$ [kN]	10,1	13,4	19,6	29,7	50,4	74,8	82,5	95,3
		$h_{ef,max} = 20*d$	$N_{Rd,p}$ [kN]	20,1	29,7	42,7	76,0	118,7	170,9	178,1	204,2

Chemical Anchor EASF

CRACKED CONCRETE	24 °C / 40 °C	$h_{ef,min}$	$N_{Rd,p}$	[kN]	5,2	5,4	7,8	11,8	16,7	22,1	32,1	40,8
		$h_{ef,standard}$	$N_{Rd,p}$	[kN]	7,0	8,2	12,2	18,5	31,5	48,4	74,2	95,3
		$h_{ef,max} = 20*d$	$N_{Rd,p}$	[kN]	13,9	18,2	26,6	47,4	74,0	110,6	160,3	204,2
	50 °C / 80 °C	$h_{ef,min}$	$N_{Rd,p}$	[kN]	3,7	3,8	5,4	8,3	11,7	15,5	22,4	28,6
		$h_{ef,standard}$	$N_{Rd,p}$	[kN]	4,9	5,7	8,5	13,0	22,0	33,9	52,0	66,7
		$h_{ef,max} = 20*d$	$N_{Rd,p}$	[kN]	9,8	12,7	18,6	33,2	51,8	77,4	112,2	142,9

- (1) For more detailed load information, please Declaration of Performance(DOP).
- (2) Short term temperature / long term temperature. Long term concrete temperatures are roughly constant over significant periods of time. Short term elevated temperatures are those that occur over brief intervals, e.g. as a result of diurnal cycling.



Load values – Design Resistance – Rebar

Design resistance values to tension load - rebar

Steel Failure - Design resistance

Size			Ø8	Ø10	Ø12	Ø14	Ø16	Ø20	Ø25	Ø28	Ø32
Rebar Grade BSt 500 S	$N_{Rk,s}$	[kN]	18	29	41	56	74	115	180	226	295

Design resistance values to shear load - rebar

Steel Failure - Design resistance

Size			Ø8	Ø10	Ø12	Ø14	Ø16	Ø20	Ø25	Ø28	Ø32
Rebar Grade BSt 500 S	$V_{Rk,s}$	[kN]	9	14	21	28	37	58	90	113	147

Design resistance values to tension load - rebar ⁽¹⁾

Design bond resistance in non-cracked concrete C20/25

Concrete Class	Temperature Range ⁽²⁾	Embedment depth	Size	Ø8	Ø10	Ø12	Ø14	Ø16	Ø20	Ø25	Ø28	Ø32	
NON-CRACKED CONCRETE	24 °C / 40 °C	$h_{ef,min}$	$N_{Rk,p}$	[kN]	10,1	12,6	17,6	22,0	25,7	34,6	43,6	54,7	60,8
		$h_{ef,standard}$	$N_{Rk,p}$	[kN]	13,4	18,8	27,6	33,7	40,1	65,3	91,6	122,2	132,9
		$h_{ef,max} = 20*d$	$N_{Rk,p}$	[kN]	26,8	41,9	60,3	82,1	102,8	153,6	218,2	273,7	303,8
	50 °C / 80 °C	$h_{ef,min}$	$N_{Rk,p}$	[kN]	7,2	9,0	12,7	15,8	18,5	24,9	31,4	37,2	41,3
		$h_{ef,standard}$	$N_{Rk,p}$	[kN]	9,7	13,6	19,9	24,3	28,9	47,0	66,0	83,1	90,4
		$h_{ef,max} = 20*d$	$N_{Rk,p}$	[kN]	19,3	30,2	43,4	59,1	74,0	110,6	157,1	186,1	206,6
CRACKED CONCRETE	24 °C / 40 °C	$h_{ef,min}$	$N_{Rk,p}$	[kN]	5,2	5,4	7,8	9,7	11,8	17,3	27,5	35,6	46,5
		$h_{ef,standard}$	$N_{Rk,p}$	[kN]	7,0	8,2	12,2	14,9	18,5	32,6	57,7	79,4	101,6
		$h_{ef,max} = 20*d$	$N_{Rk,p}$	[kN]	13,9	18,2	26,6	36,3	47,4	76,8	137,4	177,9	232,3

Chemical Anchor EASF

50°C / 80°C	$h_{ef,min}$	$N_{Rk,p}$	[kN]	3,7	3,8	5,4	6,8	8,3	12,1	19,2	24,9	32,5
	$h_{ef,standard}$	$N_{Rk,p}$	[kN]	4,9	5,7	8,5	10,4	13,0	22,8	40,4	55,6	71,2
	$h_{ef,max} = 20*d$	$N_{Rk,p}$	[kN]	9,8	12,7	18,6	25,4	33,2	53,8	96,2	124,5	162,6

- (1) For more detailed load information, please Declaration of Performance(DOP).
- (2) Short term temperature / long term temperature. Long term concrete temperatures are roughly constant over significant periods of time. Short term elevated temperatures are those that occur over brief intervals, e.g. as a result of diurnal cycling.



Load values – Maximum load recommended – Threaded bar

The recommended loads are only valid for single anchor for a roughly design, if the following conditions are valid:

$$c \geq c_{cr,N} \quad s \geq s_{cr,N} \quad h \geq 2 * h_{ef}$$

The safety factors are already included in the recommended loads.

Maximum loads recommended - Tension load – threaded bar

Steel Failure - Recommended load

Size			M8	M10	M12	M16	M20	M24	M27	M30
Steel grade 5.8	$N_{Rec,s}$	[kN]	9	14	20	38	59	84	110	134
Steel grade 8.8	$N_{Rec,s}$	[kN]	14	22	32	60	93	134	175	214
Steel grade 10.9	$N_{Rec,s}$	[kN]	19	30	43	80	125	180	234	286
Stainless Steel grade A4-70	$N_{Rec,s}$	[kN]	10	15	22	41	65	93	121	148
Stainless Steel grade A4-80	$N_{Rec,s}$	[kN]	13	21	30	56	88	126	164	200
Stainless Steel grade 1,4529	$N_{Rec,s}$	[kN]	12	20	28	52	82	118	153	187

Maximum loads recommended - Shear load – threaded bar

Steel Failure - Recommended load

Size			M8	M10	M12	M16	M20	M24	M27	M30
Steel grade 5.8	$V_{Rd,s}$	[kN]	5	9	12	22	35	50	66	80
Steel grade 8.8	$V_{Rd,s}$	[kN]	9	13	19	36	56	81	105	128
Steel grade 10.9	$V_{Rd,s}$	[kN]	9	14	20	38	59	84	110	134
Stainless Steel grade A4-70	$V_{Rd,s}$	[kN]	6	9	14	25	39	57	74	90
Stainless Steel grade A4-80	$V_{Rd,s}$	[kN]	8	12	18	34	53	76	99	120
Stainless Steel grade 1,4529	$V_{Rd,s}$	[kN]	7	11	17	31	49	71	92	112

Maximum loads recommended - Tension load – threaded bar ⁽¹⁾

Recommended load in non-cracked concrete C20/25

Concrete Class	Temperature Range ⁽²⁾	Embedment depth	Size	M8	M10	M12	M16	M20	M24	M27	M30
----------------	----------------------------------	-----------------	------	----	-----	-----	-----	-----	-----	-----	-----

Chemical Anchor EASF

Concrete Condition	Temperature	Embedment Depth	N _{Rec,p,stat}	[kN]	Recommended Load Values								
					Ø8	Ø10	Ø12	Ø14	Ø16	Ø20	Ø25	Ø28	Ø32
NON-CRACKED CONCRETE	24 °C / 40 °C	h _{ef,min}	N _{Rec,p,stat}	[kN]	7,2	9,0	12,6	19,1	24,7	31,6	36,4	40,4	
		h _{ef,standard}	N _{Rec,p,stat}	[kN]	9,6	13,5	19,7	29,9	46,6	69,1	84,1	94,2	
		h _{ef,max} = 20*d	N _{Rec,p,stat}	[kN]	19,1	29,9	43,1	76,6	109,7	158,0	181,8	202,0	
	50 °C / 80 °C	h _{ef,min}	N _{Rec,p,stat}	[kN]	5,4	6,4	8,9	13,6	19,1	24,4	25,4	29,2	
		h _{ef,standard}	N _{Rec,p,stat}	[kN]	7,2	9,5	14,0	21,2	36,0	53,4	58,9	68,1	
		h _{ef,max} = 20*d	N _{Rec,p,stat}	[kN]	14,4	21,2	30,5	54,3	84,8	122,1	127,2	145,9	
CRACKED CONCRETE	24 °C / 40 °C	h _{ef,min}	N _{Rec,p,stat}	[kN]	3,7	3,9	5,6	8,5	11,9	15,8	22,9	29,2	
			N _{Rec,p,seis}	[kN]	2,5	2,6	3,8	5,8	8,1	10,9	15,8	20,1	
		h _{ef,standard}	N _{Rec,p,stat}	[kN]	5,0	5,8	8,7	13,2	22,5	34,6	53,0	68,1	
			N _{Rec,p,seis}	[kN]	3,4	4,0	5,9	9,0	15,3	23,8	36,6	47,0	
		h _{ef,max} = 20*d	N _{Rec,p,stat}	[kN]	10,0	13,0	19,0	33,8	52,9	79,0	114,5	145,9	
			N _{Rec,p,seis}	[kN]	6,8	8,8	12,9	23,0	35,9	54,5	79,0	100,6	
	50 °C / 80 °C	h _{ef,min}	N _{Rec,p,stat}	[kN]	2,6	2,7	3,9	5,9	8,3	11,1	16,0	20,4	
			N _{Rec,p,seis}	[kN]	1,8	1,9	2,6	4,0	5,7	7,6	11,1	14,1	
		h _{ef,standard}	N _{Rec,p,stat}	[kN]	3,5	4,1	6,1	9,3	15,7	24,2	37,1	47,6	
			N _{Rec,p,seis}	[kN]	2,4	2,8	4,2	6,3	10,7	16,7	25,6	32,9	
		h _{ef,max} = 20*d	N _{Rec,p,stat}	[kN]	7,0	9,1	13,3	23,7	37,0	55,3	80,2	102,1	
			N _{Rec,p,seis}	[kN]	4,7	6,2	9,1	16,1	25,2	38,2	55,3	70,5	

- (1) For more detailed load information, please Declaration of Performance(DOP).
- (2) Short term temperature / long term temperature. Long term concrete temperatures are roughly constant over significant periods of time. Short term elevated temperatures are those that occur over brief intervals, e.g. as a result of diurnal cycling.



Load values – Maximum load recommended – Rebar

The recommended loads are only valid for single anchor for a roughly design, if the following conditions are valid:

$$C \geq C_{Cr,N} \quad S \geq S_{Cr,N} \quad h \geq 2 \cdot h_{ef}$$

The safety factors are already included in the recommended loads.

Maximum loads recommended – Tension load

Steel Failure – Recommended load

Size			Ø8	Ø10	Ø12	Ø14	Ø16	Ø20	Ø25	Ø28	Ø32
Rebar Grade BSt 500 S	N _{Rk,s}	[kN]	13	21	30	40	53	82	129	161	211

Maximum loads recommended – Shear load

Steel Failure – Recommended load

Size	Ø8	Ø10	Ø12	Ø14	Ø16	Ø20	Ø25	Ø28	Ø32
------	----	-----	-----	-----	-----	-----	-----	-----	-----

Chemical Anchor EASF

Rebar Grade BSt 500 S

 $V_{Rk,s}$

[kN]

7

10

15

20

26

41

64

81

105

Maximum load values to tension load ⁽¹⁾

Design bond resistance in non-cracked concrete C20/25

Concrete Class	Temperature Range ⁽²⁾	Embedment depth	Size	Ø8	Ø10	Ø12	Ø14	Ø16	Ø20	Ø25	Ø28	Ø32
NON-CRACKED CONCRETE	24 °C / 40 °C	$h_{ef,min}$	$N_{Rec,p,stat}$ [kN]	7,2	9,0	12,6	15,7	18,4	24,7	31,2	39,1	43,4
		$h_{ef,standard}$	$N_{Rec,p,stat}$ [kN]	9,6	13,5	19,7	24,1	28,7	46,6	65,4	87,3	94,9
		$h_{ef,max} = 20*d$	$N_{Rec,p,stat}$ [kN]	19,1	29,9	43,1	58,6	73,4	109,7	155,8	195,5	217,0
	50 °C / 80 °C	$h_{ef,min}$	$N_{Rec,p,stat}$ [kN]	5,2	6,5	9,0	11,3	13,2	17,8	22,4	26,6	29,5
		$h_{ef,standard}$	$N_{Rec,p,stat}$ [kN]	6,9	9,7	14,2	17,3	20,6	33,6	47,1	59,3	64,6
		$h_{ef,max} = 20*d$	$N_{Rec,p,stat}$ [kN]	13,8	21,5	31,0	42,2	52,9	79,0	112,2	132,9	147,6
CRACKED CONCRETE	24 °C / 40 °C	$h_{ef,min}$	$N_{Rec,p,stat}$ [kN]	3,7	3,9	5,6	6,9	8,5	12,3	19,6	25,4	33,2
			$N_{Rec,p,seis}$ [kN]	2,7	2,8	4,0	5,0	6,0	8,8	14,0	18,2	23,7
		$h_{ef,standard}$	$N_{Rec,p,stat}$ [kN]	5,0	5,8	8,7	10,6	13,2	23,3	41,2	56,7	72,6
			$N_{Rec,p,seis}$ [kN]	3,6	4,2	6,2	7,6	9,4	16,7	29,5	40,5	51,9
		$h_{ef,max} = 20*d$	$N_{Rec,p,stat}$ [kN]	10,0	13,0	19,0	25,9	33,8	54,9	98,2	127,1	166,0
			$N_{Rec,p,seis}$ [kN]	7,1	9,3	13,6	18,5	24,2	39,2	70,1	90,8	118,5
	50 °C / 80 °C	$h_{ef,min}$	$N_{Rec,p,stat}$ [kN]	2,6	2,7	3,9	4,9	5,9	8,6	13,7	17,8	23,2
			$N_{Rec,p,seis}$ [kN]	1,8	1,9	2,6	3,3	4,0	6,0	9,5	12,3	15,8
		$h_{ef,standard}$	$N_{Rec,p,stat}$ [kN]	3,5	4,1	6,1	7,4	9,3	16,3	28,9	39,7	50,8
			$N_{Rec,p,seis}$ [kN]	2,4	2,8	4,2	5,1	6,3	11,3	19,9	27,4	34,6
		$h_{ef,max} = 20*d$	$N_{Rec,p,stat}$ [kN]	7,0	9,1	13,3	18,1	23,7	38,4	68,7	88,9	116,2
			$N_{Rec,p,seis}$ [kN]	4,7	6,2	9,1	12,3	16,1	26,5	47,4	61,4	79,0

(1) For more detailed load information, please Declaration of Performance(DOP).

(2) Short term temperature / long term temperature. Long term concrete temperatures are roughly constant over significant periods of time. Short term elevated temperatures are those that occur over brief intervals, e.g. as a result of diurnal cycling.

TDS

Chemical Anchor EASF



Chemical resistance of cured anchor

Chemical environment	Concentration	Result	Chemical environment	Concentration	Result
Aqueous Solution Acetic Acid	10%	G	Heptane	100%	C
Acetone	100%	F	Hexane	100%	C
Aluminium Chloride Aqueous Solution	Saturated	G	Hydrochloric Acid	10%	G
Aluminium Nitrate Aqueous Solution	10%	G	Hydrochloric Acid	15%	G
Ammonia Aqueous Solution	5%	F	Hydrochloric Acid	25%	C
Jet Fuel	100%	F	Hydrogen Sulphide	100%	G
Benzene	100%	F	Isopropyl Alcohol	100%	F
Benzoic Acid	Saturated	G	Linseed Oil	100%	G
Benzyl Alcohol	100%	F	Lubricating Oil	100%	G
Sodium Hypochlorite Solution	15%	G	Mineral Oil	100%	G
Butyl Alcohol	100%	C	Paraffin / Kerosene	100%	C
Calcium Sulphate Aqueous Solution	Saturated	G	Phenol Aqueous Solution	1%	F
Carbon Monoxide	100%	G	Phosphoric Acid	50%	G
Carbon Tetrachloride	100%	C	Potassium Hydroxide	10% pH13	C
Chlorine Water	Saturated	F	Sea Water	100%	C
Chloro Benzene	100%	F	Styrene	100%	F
Citric Acid Aqueous Solution	Saturated	G	Sulphur Dioxide Solution	10%	G
Cyclohexanol	100%	G	Sulphuric Acid	10%	G
Diesel Fuel	100%	G	Sulphuric Acid	50%	G
Diethylene Glycol	100%	G	Turpentine	100%	C
Ethanol Aqueous Solution	95%	F	White Spirit	100%	G
Ethanol Aqueous Solution	20%	C	Xylene	100%	F
Resistance up to 75C with minimum 80% retained properties					G
Resistance up to 25C with minimum 80% retained properties					C
No data					N

Chemical Anchor EASF



Physical properties

Density (at +20°C)	ASTM D1875	g/ml	1.7
Hardness Shore D			90
Tensile Modulus	ASTM D638	N/mm ²	13800
Compressive strength	BS 6319	N/mm ²	95
Service temperature	-	-	-40°C - +80°C* *maximum long term temperature is 50°C



Consumption table

Consumption of chemical anchor depends on the dimensions of threaded bar and drilled hole. The table given below shows the theoretical consumption of chemical anchor with recommended application parameters.

Threaded bar	M8	M10	M12	M16	M20	M24	M27	M30
Diameter of threaded bar (mm)	8	10	12	16	20	24	27	30
Diameter of hole in concrete (mm)	10	12	14	18	24	28	32	35
Anchoring depth (mm)	80	90	110	125	170	210	250	280
Consumption per hole (ml)	3	4	6	9	31	45	75	93
Number of holes with 300ml cartridge	87	63	44	29	8	6	3	2
Number of holes with 345ml cartridge	100	73	50	34	10	7	4	3
Number of holes with 410ml cartridge	119	86	60	40	11	8	5	4



Directions for use

Cartridge preparation

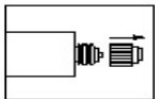

- 1) Open the cap at the tip of the cartridge.

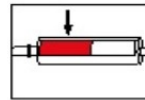

- 2) Place the cartridge into application gun.

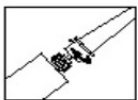

- 3) Place mixing nozzle to the cartridge (Screw down and tight)



- 4) Extrude the product by 10cm to ensure homogenous mixing.

Application of the product

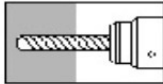

- 1) Choose the drill bit suitable for the diameter of the anchor showed in consumption table.

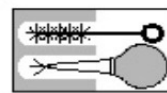

- 2) Clean inside of the hole with air pump or brush.



- 3) Fill 2/3 of the hole by injecting Chemical Anchor.

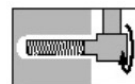

- 4) Place anchoring bar by rotating. Spare resin must overflow out of the hole.

Chemical Anchor EASF



Packaging

Cartridge	Pieces in a box	Pieces on a wooden pallet
300ml	20	1500
345ml	12	1200
410ml	12	1200

- For each cartridge, there are two static mixers in the box.



Storage and shelf life

Keep product in its original container at 22°C and avoid contacting with direct sunlight. Storage below 5°C and above 25°C can negatively affect product properties.

Material removed from its original container can be contaminated during usage which affects both adhesive performance and storage life. Therefore, do not return contaminated product to the original container.

Metsan cannot take any responsibility for product which has been contaminated or stored under conditions different than previously indicated.

Shelf life: 18 months at 22°C



Health and safety

For further information, please consult Safety Data Sheet (SDS) before use.